

Contract Summary Sheet

Contract (PO) Number: 1161

Specification Number: B91557601

Name of Contractor: JCDECAUX CHICAGO, LLC

City Department: PLANNING & DEVELOPMENT

Title of Contract: T9155760101 COORDINATED STREET FURNITURE PROGRAM AGREEMENT

Term of Contract: Start Date: 6/28/2002

End Date: 12/31/2012

Dollar Amount of Contract (or maximum compensation if a Term Agreement) (DUR):
\$0.00

Brief Description of Work: T9155760101 COORDINATED STREET FURNITURE PROGRAM AGREEMENT

Procurement Services Contract Area: REVENUE

Please refer to the DPS website for Contact information under "Doing Business With The City".

Vendor Number: 50061342

Submission Date: 8/21/2003

Specification No. B91557601

COORDINATED STREET FURNITURE PROGRAM AGREEMENT

BETWEEN

THE CITY OF CHICAGO

AND

JCDECAUX CHICAGO, LLC

**RICHARD M. DALEY
MAYOR**

TABLE OF CONTENTS

PREAMBLES 1

TERMS AND CONDITIONS 2

ARTICLE 1 INCORPORATION OF PREAMBLES 2

ARTICLE 2 DEFINITIONS 2

 2.1 Definitions 2

 2.2 Interpretation 8

 2.3 Incorporation of Exhibits 8

ARTICLE 3 GENERAL CONDITIONS FOR PERFORMANCE OF WORK 9

 3.1 Intent of Agreement 9

 3.2 Qualified Personnel 9

 3.3 City Review 9

 3.4 Contractor to Pay for All Items of Work 9

 3.5 Site and Local Conditions 10

 3.6 Permits 11

 3.7 Correction of Work 11

 3.8 Deliverables 11

 3.9 Records and Audits 13

 3.10 Confidentiality 13

 3.11 Ownership of Documents 14

 3.12 Intellectual Property Rights 15

 3.13 Royalties, Related Fees and Indemnification for Infringement 16

 3.14 Personnel 16

 3.15 Minority and Women’s Business Enterprises Commitment 17

 3.16 Safety 18

 3.17 Assignments and Subcontracts 19

 3.18 Warranty 20

 3.19 Payment and Performance Bond 20

 3.20 Parent Guarantees 26

ARTICLE 4 COORDINATED STREET FURNITURE PROGRAM AND RELATED SERVICES 25

 4.1 Design of Street Furniture 25

 4.2 Manufacture of Street Furniture 26

 4.3 Dismantlement and Removal of Existing Street Furniture 26

 4.4 Installation of Street Furniture 27

 4.5 Electricity for Street Furniture 34

 4.6 Maintenance of Street Furniture 35

4.7	Advertising on Street Furniture	36
4.8	Removal of Street Furniture at Termination or Expiration of Agreement	39
4.9	Relocation of Street Furniture	40
4.10	Ownership of Street Furniture	43
4.11	Licensing Arrangements	43
4.12	Agreement to Supersede Initial Multiple Newsrack Program Agreement	44
4.13	Compliance with Settlement Agreement	44
4.14	Space in Multiple Newsracks	44
4.15	Vendors' and Bus Supervisors' Use of Street Furniture	44
ARTICLE 5	TERM OF PERFORMANCE	45
5.1	Term of Performance	45
5.2	Timeliness of Performance	45
5.3	Agreement Extension Option.	46
ARTICLE 6	FEES	47
6.1	Amounts Due City	47
6.2	Method of Payment	48
6.3	Late Payments.	48
ARTICLE 7	DISPUTES	48
7.1	Dispute Resolution.	48
ARTICLE 8	INSURANCE	49
8.1	Insurance.	49
ARTICLE 9	INDEMNIFICATION	52
9.1	Contractor's Indemnification.	52
ARTICLE 10	COMPLIANCE WITH LEGAL REQUIREMENTS	54
10.1	General.	54
10.2	Federal Requirements	55
10.3	State Requirements.	55
10.4	City Requirements.	56
10.5	Subcontractors	60
ARTICLE 11	SPECIAL CONDITIONS	60
11.1	Warranties and Representations	60
11.2	Ethics	61
11.3	Joint and Several Liability	61
11.4	Business Documents	61
11.5	Prohibited Conflicts	62
11.6	No Liability of Public Officials	63

ARTICLE 12	EVENTS OF DEFAULT, REMEDIES, TERMINATION, SUSPENSION AND EXCUSABLE EVENTS	63
12.1	Events of Default Defined	63
12.2	Remedies.	64
12.3	Suspension	68
12.4	Payment of Excess Costs	68
12.5	Excusable Events and Schedule and Fee Adjustments	68
ARTICLE 13	MISCELLANEOUS	72
13.1	Entire Agreement	72
13.2	No Collateral Agreements.	72
13.3	No Omissions	72
13.4	Counterparts	73
13.5	Amendments	73
13.6	Approval.	73
13.7	Governing Law and Jurisdiction	73
13.8	Severability	73
13.9	Assigns.	74
13.10	Cooperation	74
13.11	Waiver.	74
13.12	Independent Contractor Status.	74
13.13	Notices.	75
13.14	Rights Cumulative.	76
13.15	Authority.	76

List of Exhibits

Exhibit 1A	Description of Street Furniture, Including Specifications
Exhibit 1B	Street Furniture Sites
Exhibit 1C	Installation Schedule (Phase I and Phase II)
Exhibit 1D	Maintenance and Operation Standards
Exhibit 1E	Preventative Maintenance Plan
Exhibit 2	Contractor Fee Schedule and Abatement Schedule
Exhibit 3	MBE/WBE Special Conditions and Schedules C-1 and D-1
Exhibit 4	Disclosure Affidavit
Exhibit 5	Evidence of Insurance
Exhibit 6	Form of Performance and Payment Bond
Exhibit 7	List of Key Personnel and Schedule of Availability
Exhibit 8	Additional Specifications Relating to Work to be Performed on the Public Way
Exhibit 9	Average Installation Costs of Street Furniture
Exhibit 10	Prevailing Wage Rates
Exhibit 11	Contractor's Advertising Policy
Exhibit 12	Forms of Parent Guarantees
Exhibit 13	Map of CBD-A

COORDINATED STREET FURNITURE PROGRAM AGREEMENT

This Coordinated Street Furniture Program Agreement is entered into as of the 28th day of June, 2002 (the "**Commencement Date**"), by and between JCDecaux Chicago, LLC, an Illinois limited liability company (the "**Contractor**"), and the City of Chicago, a municipal corporation and home rule unit of local government existing under the Constitution of the State of Illinois, acting through its Department of Planning and Development and Department of Transportation (the "**City**"), at Chicago, Illinois.

PREAMBLES

WHEREAS, the City issued a request for proposals for a coordinated street furniture program;

WHEREAS, the City has negotiated with the Contractor with respect to the design, fabrication, installation, maintenance, operation, removal and dismantlement of various pieces of street furniture, at no cost to the City, in exchange for the City's allowing the Contractor to place advertising on certain types and pieces of street furniture, in accordance with an ordinance relating to street furniture passed by the City Council of the City of Chicago on June 9, 1999 (Journal of Council Proceeds of the City Council of the City of Chicago; C.J.P., pp. 5442-53; June 9, 1999) (the "**June 9 Ordinance**"), this Agreement and all other applicable laws and ordinances, and subject to the City's approval;

WHEREAS, the City's allowing the Contractor to place advertising on certain types and pieces of street furniture is valuable to the Contractor because it may generate revenues from the sale of such advertising;

WHEREAS, the Contractor has agreed to pay the City certain fees and has agreed to be responsible for the design, fabrication, installation, maintenance, operation, removal and dismantlement of various pieces of street furniture at locations approved by the City at no cost to the City;

WHEREAS, the Contractor's obligation to pay such fees to the City is independent of the Contractor's obligations under this Agreement with respect to the design, fabrication, installation, maintenance, operation, removal and dismantlement of the street furniture at locations approved by the City at no cost to the City;

WHEREAS, the Contractor's obligation to pay such fees to the City is independent of the revenues, if any, that the Contractor may generate from the sale of advertising on the street furniture; and

WHEREAS, the Contractor represents that it has the professional experience and expertise to provide the necessary street furniture and related work and further warrants that it is ready, willing and able to perform in accordance with the terms and conditions as set forth in this Agreement.

NOW, THEREFORE, the City and the Contractor agree as follows:

TERMS AND CONDITIONS

ARTICLE 1 INCORPORATION OF PREAMBLES

The Preambles above are hereby incorporated by this reference as if fully set forth herein.

ARTICLE 2 DEFINITIONS

2.1 Definitions.

The following words and phrases have the following meanings for purposes of this Agreement:

“**ADAAG**” has the meaning given such term in Section 4.1(d).

“**Additional Newsrack**” has the meaning given such term in Section 4.4(e)(i).

“**Additional Shelter**” has the meaning given such term in Section 4.4(d)(i).

“**Ad Panel**” means an advertising display area located on a piece of Street Furniture on which the Contractor may place advertising (including fixed and scrolling advertisements) in accordance with the terms of this Agreement.

“**Agreement**” means this Coordinated Street Furniture Program Agreement, including all exhibits attached to it and incorporated in it by reference, and all amendments, modifications or revisions made in accordance with its terms.

“**Bonded Obligations**” has the meaning given such term in Section 3.19(a)(i).

“**Bus Stop Shelter**” means a structure providing shelter for passengers waiting for buses or other modes of transportation, to be installed (if authorized pursuant to the terms of this Agreement) by the Contractor pursuant to this Agreement.

“Bus Supervisor Shelter” means a structure providing shelter for a supervisor monitoring public transportation, to be installed (if authorized pursuant to the terms of this Agreement) by the Contractor pursuant to this Agreement.

“Cafe Kiosk” means a structure to be installed (if authorized pursuant to the terms of this Agreement) by the Contractor pursuant to this Agreement, accommodating the sale of food, beverages, flowers, newspapers, periodicals or other merchandise operated by a vendor pursuant to the authorization of the CPD or the City, as applicable.

“CDOT” means the Chicago Department of Transportation.

“Central Business District” means the area of the City bordered by North Avenue on the north, Cermak Road on the south, Lake Shore Drive on the east, and Ashland Avenue on the west.

“CBD-A” means the portion of the Central Business District identified on Exhibit 13.

“CBD-B” means the portion of the Central Business District that does not include the CBD-A.

“Change in Law” shall mean and refer to the enactment, amendment, modification or repeal by a Governmental Authority after the date of this Agreement of any Law which is applicable to the performance of the Work; it being expressly understood and agreed by the parties hereto that a change in any income tax Law or any Law by which a tax is levied or assessed on the basis of the Contractor’s income, profits, revenues or gross receipts shall not be a Change in Law and a change in any Law relating to any of the other taxes described in Section 10.1(b) shall not be a Change in Law unless the Contractor would be entitled to an abatement of Contractor Fees in relation to such change in Law, as specifically described in Section 10.1(b).

“Chicago Neighborhoods” means the areas within the City, but excluding the Central Business District.

“Chief Procurement Officer” means the Chief Procurement Officer of the City of Chicago, and any representative duly authorized in writing to act on his behalf.

“CIP” means a two-sided city information panel containing an Ad Panel on one side and a City Message on the other side, to be installed (if authorized pursuant to the terms of this Agreement) by the Contractor pursuant to this Agreement.

“City Message” means a poster or other document (but in no event non-sponsorship commercial advertising for a for-profit entity) supplied by the City for placement on an Ad Panel, including, without limitation, a map, schedule, public service information, promotional piece or advertisement for services, programs, messages and events sponsored or supported by the City, the CPD or the CTA.

“City Ordinance” means an ordinance adopted by the City Council of the City.

“Commissioner of CDOT” means the Commissioner of CDOT, and any representative authorized in writing to act on such Commissioner’s behalf.

“Commissioner of DPD” means the Commissioner of DPD, and any representative authorized in writing to act on such Commissioner’s behalf.

“Complete Installation Permit Application” means a fully and properly completed Installation Permit Application which meets the standards established by the City for issuance of an Installation Permit and which is in form and substance acceptable to the City.

“Consulting Parties” has the meaning given such term in Section 11.5(b)(i).

“Contractor Fees” means the fees to be paid by the Contractor to the City pursuant to this Agreement, as set forth in the Contractor Fee Schedule attached hereto as Exhibit 2.

“Contract Year” means a one year period during the term of this Agreement. The first Contract Year begins on the Commencement Date and ends on the day prior to the one year anniversary thereof. Each subsequent Contract Year shall begin on the immediately following anniversary of the Commencement Date and end on the day prior to the next anniversary thereof.

“CPD” means the Chicago Park District.

“CTA” means the Chicago Transit Authority.

“Cure Notice” has the meaning given such term in Section 12.2(b).

“Default Notice” has the meaning given such term in Section 12.2(b).

“Deliverables” has the meaning given such term in Section 3.8 (a).

“DPD” means the City of Chicago Department of Planning and Development.

“Economic Loss” means a loss of revenue suffered by the Contractor because (i) the Contractor is, after using all reasonable efforts, unable to sell advertising for placement on one or more Ad Panels because the Ad Panels do not exist (because they have been destroyed, substantially obscured from public view, removed at the direction of the City or the Contractor has not received Installation Permits for the Street Furniture to be equipped with such Ad Panels) or (ii) an advertiser who previously agreed to purchase advertising on an Ad Panel has refused to pay for such advertising for good cause, as reasonably determined by the Project Manager (irrespective of the terms of the Contractor’s contract or other arrangements with such advertiser).

“Excusable Event” has the meaning given such term in Section 12.5(f).

“Governmental Authority” means any United States national, federal, state, county, municipal (including, without limitation, the City) or local government, agency, authority or court, or any department, board, bureau or instrumentality thereof.

“Indemnitees” has the meaning given such term in Section 9.1(b).

“Initial Fee” has the meaning given such term in Section 6.1(a)(ii).

“Initial Installation Permits” means the Installation Permits to be applied for by the Contractor for the installation of the 325 Bus Stop Shelters identified in the column marked “Initial Central Business District” and the 325 Bus Stop Shelters identified in the column marked “Initial Chicago Neighborhoods” on Exhibit 1B.

“Initial Multiple Newsrack Program” means JCDecaux Chicago, Inc.’s provision of Multiple Newsracks and related services pursuant to the Initial Multiple Newsrack Program Agreement.

“Initial Multiple Newsrack Program Agreement” means the Agreement between the City and JCDecaux Chicago, Inc., dated as of July 7, 1998 (and amended on July 8, 1998, January 14, 1999 and May 21, 1999), relating to the Initial Multiple Newsrack Program.

“Installation Bond” has the meaning given such term in Section 3.19(a)(ii)(A).

“Installation Deadline” has the meaning given such term in Section 5.2(c).

“Installation Permit” means the permit(s) and approvals the Contractor must obtain from the City with respect to an individual piece of Street Furniture, in addition to permits and approvals the Contractor must obtain from other Governmental Authorities, before the Contractor can begin installation of such piece of Street Furniture.

“Installation Schedule” means the schedule for the installation of the Street Furniture, attached hereto as Exhibit 1C.

“Installation Permit Application” means the application(s) the Contractor must file with the City in order to receive an Installation Permit for a piece of Street Furniture.

“Key Personnel” has the meaning given such term in Section 3.14(b).

“Law” means any constitution, charter, statute, act, law, regulation, code, rule, order, ordinance (including, without limitation, any City Ordinance), decree, permit, judgment, directive,

ruling, decision, guideline, resolution, executive order or declaration of any Governmental Authority, or any interpretation or application thereof by any such Governmental Authority.

“**Losses**” has the meaning given such term in Section 9.1(b).

“**Maintenance Bond**” has the meaning given such term in Section 3.19(a)(ii)(B).

“**Multiple Newsrack**” means a structure combining multiple boxes or units for the vending or distribution of newspapers and periodicals, installed or to be installed (if authorized pursuant to the terms of this Agreement) by JCDecaux Chicago, Inc. pursuant to the Pilot Program Agreement or by the Contractor pursuant to this Agreement, respectively.

“**Newsstand**” means a structure accommodating the sale of newspapers, periodicals and other merchandise by a vendor selected by the City, to be installed (if authorized pursuant to the terms of this Agreement) by the Contractor pursuant to this Agreement.

“**Out-Sourced Costs**” has the meaning given such term in Section 3.15.

“**Payment and Performance Bonds**” has the meaning given such term in Section 3.19(a).

“**Permit Application Date**” has the meaning given such term in Section 4.4(a)(ix).

“**Permit Issuance Date**” has the meaning given such term in Section 4.4(a)(x).

“**Phase I**” means Phase I of the Installation Schedule, identified as such in Exhibit 1C attached hereto.

“**Phase II**” means Phase II of the Installation Schedule, identified as such in Exhibit 1C attached hereto.

“**Plans and Specifications**” has the meaning given such term in Section 3.11.

“**Prevailing Wage Act**” has the meaning given such term in Section 10.3(e).

“**Project Manager**” means the project manager designated by the City from time to time as its project manager for the Street Furniture program implemented pursuant to this Agreement.

“**Removal Bond**” has the meaning given such term in Section 3.19(a)(ii)(C).

“**Satisfactory Performance**” means, for the purposes of only Section 5.3 of this Agreement, the following: (i) the Contractor has made all payments to the City when due as required by this Agreement; (ii) the Contractor has installed all Street Furniture as required by this Agreement; (iii) the Contractor has not materially failed to maintain all Street Furniture as required by this Agreement;

(iv) the Contractor has complied with the requirements of Section 3.15 and Exhibit 3 to this Agreement relating to the minority and women's business enterprises commitment; and (v) the Contractor has not been declared in default (after exhausting all applicable opportunities for cure provided pursuant to Sections 12.2 (a) and (b) of this Agreement) with respect to two or more other material breaches of this Agreement and is not then in default of this Agreement (after exhausting all applicable opportunities for cure provided pursuant to Sections 12.2 (a) and (b) of this Agreement).

"Settlement Agreement" means that certain Agreement between the City and Chicago Sun-Times, Inc., Hartman Publishing Group, Inc., Chicago Reader, Inc., New City Communications, Inc. and Chicago Tribune Company, dated as of June 1998, relating to the Initial Multiple Newsrack Program.

"Site Selection Criteria" has the meaning given such term in Section 4.4(a)(iv).

"Site Selection Date" has the meaning given such term in Section 4.4(a)(vi).

"Status Report" has the meaning given such term in Section 3.8(c).

"Street Furniture" means, collectively, 2,175 Bus Stop Shelters, 110 Multiple Newsracks, 26 Newsstands, five Cafe Kiosks, 75 CIPs and 17 Bus Supervisor Shelters being provided (each if authorized pursuant to the terms of this Agreement) in the City by the Contractor pursuant to this Agreement, as more fully described on Exhibit 1A attached hereto and such other street furniture as the City may authorize the Contractor to install from time to time.

"Subcontractor" means any person or entity who has a contract, agreement or other arrangement to perform a portion of the Work or to supply materials, equipment or other items in relation to the Work and includes subcontractors and subconsultants of any tier, suppliers and materials providers, whether or not in privity with the Contractor.

"Substantial Damage" means an incident of damage to a piece of Street Furniture for which the Contractor's cost to repair the damage relating to such incident and such piece of Street Furniture is in excess of 50 percent of the cost to the Contractor of manufacturing a replacement piece of Street Furniture.

"Total Contract Price" has the meaning given such term in Section 3.15.

"UFAS" has the meaning given such term in Section 4.1(c).

"Work" means, collectively, the design (including architectural and engineering services), fabrication, procurement, installation, maintenance, operation, removal and dismantlement of the Street Furniture, maintenance and restoration of the underlying and other property affected by the Work and other services and items that are necessary to execute and complete the obligations of the Contractor described in this Agreement and shall include, without limitation, all such services and

items which are specifically required by this Agreement and any and all work necessary to complete or carry out the work fully and to the standard of performance required in this Agreement.

2.2 Interpretation.

- (a) The term “include” (in all its forms) means “include, without limitation” unless the context clearly states otherwise.
- (b) All references in this Agreement to Articles, Sections or Exhibits, unless otherwise expressed or indicated, are to the Articles, Sections or Exhibits of this Agreement.
- (c) Words importing persons include firms, associations, partnerships, trusts, corporations and other legal entities, including public bodies, as well as natural persons.
- (d) Any headings preceding the text of the Articles and Sections of this Agreement, and any table of contents or marginal notes appended to it, are solely for convenience of reference and do not constitute a part of this Agreement, nor do they affect the meaning, construction or effect of this Agreement.
- (e) Words importing the singular include the plural and vice versa. Words of the masculine gender include the correlative words of the feminine and neuter genders.
- (f) All references to a number of days mean calendar days, unless expressly indicated otherwise.

2.3 Incorporation of Exhibits.

The following attached Exhibits are incorporated herein and made a part of this Agreement:

Exhibit 1A	Description of Street Furniture, Including Specifications
Exhibit 1B	Street Furniture Sites
Exhibit 1C	Installation Schedule (Phase I and Phase II)
Exhibit 1D	Maintenance and Operation Standards
Exhibit 1E	Preventative Maintenance Plan
Exhibit 2	Contractor Fee Schedule and Abatement Schedule
Exhibit 3	MBE/WBE Special Conditions and Schedules C-1 and D-1
Exhibit 4	Disclosure Affidavits
Exhibit 5	Evidence of Insurance
Exhibit 6	Form of Performance and Payment Bond
Exhibit 7	List of Key Personnel and Schedule of Availability
Exhibit 8	Additional Specifications Relating to Work to be Performed on the Public Way
Exhibit 9	Average Installation Costs of Street Furniture

Exhibit 10	Prevailing Wage Rates
Exhibit 11	Contractor's Advertising Policy
Exhibit 12	Forms of Parent Guarantees
Exhibit 13	Map of CBD-A

ARTICLE 3
GENERAL CONDITIONS FOR PERFORMANCE OF WORK

3.1 Intent of Agreement. The intent of this Agreement is that, in consideration of the City's grant of certain rights to the Contractor to sell and place advertising on certain pieces of the Street Furniture as described herein, the Contractor will pay to the City the Contractor Fees and have the right and the obligation to design, fabricate, install, maintain, operate and dismantle the Street Furniture and maintain and restore the underlying and other surrounding property affected by the Work, or cause the Street Furniture to be designed, fabricated, installed, maintained, operated, removed and dismantled and cause the maintenance and restoration of the underlying and other surrounding property affected by the Work, in accordance with and subject to this Agreement and all applicable Laws. Further, the Contractor must take all necessary action to perform the obligations of the Contractor pursuant to this Agreement.

3.2 Qualified Personnel. The Contractor must ensure that all Work that requires the exercise of professional skills or judgment is accomplished by professionals qualified and competent in the applicable disciplines and appropriately licensed, as required by Law. The Contractor upon reasonable notice must provide copies of any such licenses to the City. The Contractor remains responsible for the professional and technical accuracy of all Work and Deliverables (as defined below) performed or furnished, whether performed or furnished by the Contractor or its Subcontractors or others on its behalf.

3.3 City Review. Any review, supervision, consent, approval or acceptance in relation to any of the Work by the City, the CPD or the CTA does not relieve the Contractor of its responsibility for the professional skill and care and technical accuracy of its Work and Deliverables. This provision in no way limits the City's rights against the Contractor either under this Agreement, at law or in equity.

3.4 Contractor to Pay for All Items of Work. The Contractor acknowledges and agrees that it must perform all Work without any payments by the City, the CPD or the CTA. In furtherance and confirmation of the foregoing, the Contractor acknowledges and agrees that the City has not made, and does not intend to make, any appropriations in relation to this Agreement. The Contractor further covenants and agrees that it must provide and pay for all items or services necessary for the proper execution and completion of the Work, whether temporary or permanent and whether or not incorporated or to be incorporated into the Work, including, but not limited to, all design, engineering, procurement, installation, construction, maintenance, removal and dismantlement services, the maintenance and restoration of the underlying and other surrounding property affected by the Work, all administration, management, training and coordination services, all labor, materials,

furnishings, equipment, supplies, insurance, bonds, permits, licenses, tests, inspections, tools, machinery, water, heat, utilities consumed in performance of the installation, maintenance and removal of the Street Furniture and restoration relating thereto and transportation, and all other items, facilities and services.

3.5 Site and Local Conditions. The Contractor will bear the full risk of site and local conditions at locations where the Work shall be performed and the Contractor will not be entitled to an adjustment to the Contractor Fee Schedule (attached hereto as Exhibit 2) or any extension in time for its performance of the Work as a result of the same. The Contractor acknowledges and agrees that it will bear the full risk of installing Street Furniture on special or unusual sidewalks, such as sidewalks made of special substances (including, without limitation, granite and marble) and sidewalks that are vaulted. Notwithstanding the foregoing, if the Contractor discovers or experiences unanticipated and unusual site or local conditions (excluding sidewalk conditions described in the preceding sentence) at a location at which the Contractor is obligated to install a piece of Street Furniture, and such site or local conditions will necessarily cause the cost of installing such piece of Street Furniture to exceed 150 percent of the average cost of installing the same type of Street Furniture (as set forth on Exhibit 9 attached hereto), the Contractor may initiate the following procedures:

(a) The Contractor may file a report with the Project Manager, documenting the site or local conditions at such location and describing in detail the cost impact of such conditions on the Contractor's cost of installing such piece of Street Furniture. Such report must be filed by the Contractor with the Project Manager no later than 30 days after the City issues an Installation Permit with respect to the relevant site. If the Contractor does not file a report within such 30-day period, the Contractor will be deemed to have waived its right to file a report relating to such site and the Contractor must proceed with the installation of the Street Furniture at such site and bear all costs thereof.

(b) The City may respond to such a report filed by the Contractor by either (i) directing the Contractor to install such piece of Street Furniture at an alternate location or, (ii) directing the Contractor to install such piece of Street Furniture at the original location. If the City directs the Contractor to install a Bus Stop Shelter at an alternate location, the City shall select such alternate location using the Site Selection Criteria (as defined below). If the City directs the Contractor to install any other piece of Street Furniture at an alternate location, the Chief Procurement Officer shall select such alternate location in his sole discretion using the same criteria and procedures that were used to select the initial site, subject to authorization by City Council, if necessary.

(c) If the City directs the Contractor as set forth in subsection (b)(ii) above, the Contractor must proceed with the installation of the piece of Street Furniture at the original location. The difference between the Contractor's actual and reasonable costs of installing such piece of Street Furniture and the average cost of installing (including cost relating to connecting to utility service) the same type of Street Furniture (as set forth on Exhibit 9 attached hereto), as reasonably determined by the City in writing, may be abated by the Contractor from its next payment of Contractor Fees to

the City. The Contractor must forward copies of all records evidencing the cost of the installation of such piece of Street Furniture to the City upon request.

3.6 Permits. The Contractor must apply for and obtain all necessary permits, licenses or other necessary forms of approval or authorization, including but not limited to the Installation Permits, for construction, installation, maintenance and removal work and the Contractor must diligently and promptly file all necessary plans with the appropriate City department. The City will endeavor to process Installation Permit Applications for the Street Furniture on a timely basis. The Contractor must install the Street Furniture in strict compliance with plans approved by CDOT.

3.7 Correction of Work. The Contractor must, at the earliest practical opportunity, correct Work (including any drawings, plans, specifications, items of construction or fabrication, or any other product constituting a part or component of the Work) (i) that the City rejects as defective or failing to conform to this Agreement (whether arising from a design, construction or other defect, error, omission or deficiency) or (ii) that is otherwise known by the Contractor or any Subcontractor to be defective or failing to conform to this Agreement. If other portions of the Work are adversely affected by or are damaged by such defective Work, the Contractor must, at its sole cost and expense and at the earliest practical opportunity, correct, repair or replace such affected or damaged Work, as well as any other property damaged by such defective or nonconforming Work. The Contractor will bear all costs of correcting such defective or nonconforming Work, including additional testing and inspections and any design or engineering services and expenses made necessary thereby. If, after the Contractor is notified by the City or otherwise becomes aware of defective or nonconforming Work, the Contractor fails to correct such defective or nonconforming Work, or any damaged Work or other property, the City may correct it and charge to the Contractor the cost of the same.

3.8 Deliverables.

(a) *Deliverables in General.* In carrying out its Work, the Contractor must prepare and provide to the City the Deliverables. The “**Deliverables**” are the following: (i) quarterly reports documenting compliance with maintenance and other standards set forth in this Agreement; (ii) On-Line Maintenance Logs (as defined below); and (iii) Status Reports (as defined below). All Deliverables must be prepared in a form and content reasonably satisfactory to the City and delivered in a timely manner consistent with the requirements of this Agreement. All Deliverables must be written in the English language or must be accompanied by an English translation. All financial and other monetary data contained in the Deliverables must be expressed in United States Dollars or must be accompanied by a conversion to United States Dollars.

(b) *Additional Documents.* In addition to the Deliverables, the City may request from time to time that the Contractor provide additional reports, studies, data, recommendations, reviews, models, samples, analyses and similar documents or other work product. The Contractor must use all reasonable efforts to provide such additional items; provided, however, that the Contractor’s failure to produce any such additional items will not be considered a default by the Contractor pursuant to Article 12. Furthermore, upon the request of the City, the Contractor must provide annual

financial statements for each calendar year that completely or partially occurs during the term of this Agreement prepared by a certified public accountant, which financial statements must demonstrate, at a minimum, the total gross advertising revenues received in relation to the Street Furniture in each such calendar year.

(c) *Status Reports.* On or before the expiration of each calendar month throughout the duration of this Agreement, the Contractor must prepare and submit to the City a status report (each a "**Status Report**"), which Status Report must be prepared in a manner and format satisfactory to the City and must include (i) a detailed description of the progress of the Work, including a critical path chart illustrating the progress which has been made, (ii) a statement of any significant Work issues that remain unresolved, and a list of the Contractor's observations and suggested recommendations or resolutions as to the same, (iii) an updated report as to the Contractor's adherence to the Installation Schedule, and specifically addressing whether the design, fabrication and installation is on schedule or behind schedule and actions being taken to correct schedule delays, (iv) a summary of any significant Work events that are scheduled to occur during the following 30 days, (v) monthly complaint logs and (vi) product manuals.

(d) *On-Line Maintenance Logs.* Throughout the term of this Agreement, the Contractor must maintain maintenance records ("**On-Line Maintenance Logs**") relating to all Street Furniture on a secure, password-protected Internet site, updated no less than every 24 hours, so that such records may be accessed at any time by the City and the CTA. Such records must include, without limitation, a record of maintenance requests and complaints, a record of each piece of Street Furniture and its location, a record of each maintenance inspection or visit for each such piece and a record of action taken and maintenance work performed with respect to each such piece. The Contractor must use all reasonable efforts to make such On-Line Maintenance Logs available prior to the installation of the first piece of Street Furniture. If the Contractor has not made the On-Line Maintenance Logs available by the date of installation of the first piece of Street Furniture, the Contractor must give the City full maintenance records in electronic format no less than once per week. The Contractor must ensure that the On-Line Maintenance Logs are available to the City and the CTA no later than 30 days after the date of installation of the first piece of Street Furniture.

(e) *Rejection of Deliverables.* The City may reject Deliverables that do not include relevant information or data, or do not include all documents or other materials required by this Section 3.8 or reasonably necessary for the purpose for which the City intends to use the Deliverables. If the City determines the Contractor has failed to comply with the foregoing standards, it may consider such failure to be a default by the Contractor for the purposes of Article 12.

(f) *Partial or Incomplete Deliverables.* Partial or incomplete Deliverables may be accepted for review only when required for a specific and well-defined purpose and when consented to in advance by the City. Such Deliverables will not be considered as satisfying the requirements of this Agreement and partial or incomplete Deliverables in no way relieve the Contractor of its commitments under this Agreement.

3.9 Records and Audits.

(a) *Records.* The Contractor must deliver or cause to be delivered to the City all documents, including but not limited to all Deliverables prepared for the City under the terms of this Agreement, promptly in accordance with the time limits prescribed in this Agreement, and if no time limit is specified, then upon reasonable demand for them or upon termination or completion of the Work under this Agreement. In the event of the failure by the Contractor to make such delivery upon demand, then and in that event, the Contractor must pay to the City any damages the City may sustain by reason of the Contractor's failure.

The Contractor must maintain any such records including Deliverables not delivered to the City or demanded by the City for a period of 5 years after the expiration or termination of this Agreement, whichever is later. The Contractor must not dispose of such documents following the expiration of this period without notification of and written approval from the City.

(b) *Audits.* The Contractor and all Subcontractors must permit the City to review information that may be requested pertaining to the performance and cost of the Work. The Contractor must maintain records showing actual revenues generated and expenditures incurred in relation to the Street Furniture and this Agreement. The Contractor must keep books, documents, paper, records and accounts in connection with the Work open to audit, inspection, copying, abstracting and transcriptions and must make these records available to the City, the CTA, the CPD and other relevant governmental agencies, at reasonable times during the performance of its Work at the Chicago office of the Contractor. In addition, the Contractor must retain such records in a safe place and make them available for audit, inspection, copying and abstracting for at least 5 years after expiration or termination of this Agreement, whichever is later.

- (i) The Contractor must maintain its books, records, documents and other evidence and adopt accounting procedures and practices sufficient to reflect properly all costs of whatever nature claimed to have been incurred and anticipated to be incurred for or in connection with the performance of this Agreement. This system of accounting must be in accordance with generally accepted accounting principles and practices, consistently applied throughout.
- (ii) No provision in this Agreement granting the City a right of access to records and documents is intended to impair, limit or affect any right of access to such records and documents that the City would have had in the absence of such provisions.

3.10 Confidentiality.

(a) *Confidentiality of Documents.* All Deliverables and reports, data, studies, findings, specifications and other documents or information, regardless of form, prepared, assembled or encountered by or provided by the Contractor under this Agreement, are the property of the City and

are confidential, except as specifically authorized in this Agreement or as may be required by Law. The Contractor may retain copies of Deliverables for its records and its use in performing the Work and the Agreement, but the Contractor must not allow the Deliverables to be made available to any other individual or organization without the prior written consent of the City. Further, all reports, data, studies, findings, specifications and other documents or information, regardless of form, provided to the Contractor by the City, the CPD or the CTA, are confidential and must not be made available to any other individual or organization without the prior written consent of the City. Notwithstanding the foregoing, the City agrees that the Contractor may make the Deliverables and information provided by the City, the CPD or the CTA available to approved Subcontractors of the first tier, legal counsel to the Contractor and accountants for the Contractor, to the extent reasonably required for the performance of the Work. The Contractor must implement such measures as may be necessary to ensure that its staff, legal counsel, accountants and Subcontractors are bound by the confidentiality provisions in this Agreement. The Contractor acknowledges and agrees that it is entrusted with or has access to valuable and confidential information and records of the City, the CPD and the CTA and with respect to that information, the Contractor agrees to be held to the standard of care of a fiduciary.

(b) *Publicity.* The Contractor must not issue any publicity news releases or grant press interviews, and except as may be required by Law during or after the performance of this Agreement, disseminate any information regarding its Work or the project to which the Work pertains without the prior written consent of the press secretary to the Mayor of the City.

(c) *Document Request.* If the Contractor is presented with a request for documents by any administrative agency or with a subpoena duces tecum regarding any records, data or documents that may be in the Contractor's possession by reason of this Agreement or its performance of the Work, the Contractor must immediately give notice to the Commissioner of CDOT, the Commissioner of DPD, the Corporation Counsel for the City, the CPD and the General Counsel of the CTA, with the understanding that the City, the CPD and the CTA will have the opportunity to contest such process by any means available to them before the records or documents are submitted to a court or other third party. The Contractor, however, is not obligated to withhold the delivery beyond the time ordered by the court or administrative agency, unless the subpoena or request is quashed or the time to produce is otherwise extended.

3.11 Ownership of Documents. All Deliverables and reports, data, findings or information in any form prepared, assembled or encountered by or provided to the Contractor under this Agreement are property of the City, including all copyrights inherent in them or their preparation. Notwithstanding the foregoing, the Contractor will continue to own the plans, specifications and designs for the Street Furniture (the "**Plans and Specifications**") to be produced by the Contractor pursuant to this Agreement, except as otherwise provided in Section 3.12(b). The Contractor may retain copies of Deliverables and similar documents for its records and its use in performing the Work and the Agreement and the City hereby grants to the Contractor a license to use such documents for such purposes. During performance of its Work, the Contractor is responsible for any loss or damage to the Deliverables, reports, data, findings or information while in the Contractor's or any

Subcontractor's possession. Any such lost or damaged Deliverables, reports, data, findings or information must be restored at the expense of the Contractor. If not restorable, the Contractor must bear the cost of replacement and of any loss suffered by the City on account of the destruction.

3.12 Intellectual Property Rights.

(a) *Grant of Rights to Deliverables.* The Contractor hereby irrevocably grants, conveys, bargains, sells, assigns, transfers and delivers to the City, its successors and assigns, all right, title and interest in and to the copyrights and all U.S. and foreign copyright registrations, copyright applications and copyright renewals for them, and other intangible, intellectual property embodied in or pertaining to the Deliverables prepared for the City under this Agreement, and all goodwill relating to them, free and clear of any liens, claims or other encumbrances, to the fullest extent permitted by Law. The Contractor may retain and use copies of the Deliverables only as expressly provided in Section 3.10(a). If any Deliverable includes any of the Contractor's proprietary documents, the Contractor hereby grants to the City an irrevocable, transferable, perpetual, royalty-free, paid-up license to use all of the Contractor's proprietary documents submitted to the City as a Deliverable for any City, CTA or CPD purpose relating to this Agreement, for the enforcement of the City's rights and remedies pursuant to this Agreement, for City planning purposes and for future street furniture or similar programs implemented or considered by the City. The Contractor's sole and exclusive remedy for a purported breach by the City of the restrictions set forth in the preceding sentence is to seek injunctive relief (to the extent available pursuant to applicable Law). The Contractor will, and will cause all of its Subcontractors, employees, agents and other persons within its control to, execute all documents and perform all acts that the City may reasonably request in order to assist the City in perfecting its rights in and to the copyrights relating to the Deliverables, at the sole expense of the City. The Contractor warrants to the City, its successors and assigns that on the date of transfer the Contractor is the lawful owner of good and marketable title in and to the copyrights for the Deliverables and has the legal rights to fully assign them. The Contractor further warrants that it has not assigned and will not assign any copyrights and that it has not granted and will not grant any licenses, exclusive or nonexclusive, to any other party, and that it is not a party to any other agreements or subject to any other restrictions with respect to the Deliverables. The Contractor warrants and represents that the Deliverables are accurate and otherwise in accordance with this Agreement and that the Deliverables either constitute a work of original authorship or the Contractor has sufficient rights in the Deliverables to comply with this Agreement.

(b) *Grant of Rights to Plans and Specifications.* Within 30 days of execution of this Agreement, the Contractor must deliver all appropriate documentation to the City so that, if the Contractor is declared to be in default of this Agreement pursuant to Article 12, and the City elects to continue to use the Street Furniture as provided herein, the Contractor must automatically and irrevocably grant to the City, its successors and assigns, an irrevocable, non-transferrable, royalty-free, paid-up license relating to the copyrights and all U.S. and foreign copyright registrations, copyright applications and copyright renewals for them, and other intangible, intellectual property embodied in or pertaining to the Plans and Specifications, and all goodwill relating to them, free and clear of any liens, claims or other encumbrances, to the fullest extent permitted by Law. In addition, such

documentation shall ensure that the Contractor has granted to the City an irrevocable, non-transferable, royalty-free, paid-up license to use the Plans and Specifications to continue any Street Furniture program. The Contractor will, and will cause all of its Subcontractors, employees, agents and other persons within its control to, execute all documents and perform all acts that the City may reasonably request in order to assist the City in perfecting its rights in and to the copyrights relating to the Plans and Specifications. The Contractor warrants to the City, its successors and assigns, that the Contractor is the lawful owner of good and marketable title in and to the copyrights for the Plans and Specifications and has the legal rights to grant a license to use them. The Contractor warrants and represents that the Plans and Specifications are complete, entire and comprehensive, and that the Plans and Specifications constitute a work of original authorship. The rights granted to the City by the Contractor pursuant to this Section 3.12(b) shall expire one year following the expiration of the term of this Agreement in which the default was declared.

3.13 Royalties, Related Fees and Indemnification for Infringement. The Contractor must pay all royalties and other fees for any patents, trademarks, copyrights or other proprietary rights necessary for the execution and completion of the Work. The Contractor must indemnify, defend and hold harmless the City, the CPD and the CTA from and against any and all Losses (as hereinafter defined) arising or resulting from any claim or legal action that any materials, supplies, equipment, processes or other portions of the Work furnished by the Contractor under this Agreement, or the use thereof, constitutes an infringement and/or violation of any patent, trademark, copyright, trade secret, intellectual property right or other proprietary right. If any such item is held to constitute an infringement, and the use of such item is enjoined, the Contractor must, at its own expense, either procure the right to use the infringing item, or replace the same with a substantially equal but non-infringing item, or modify the same to be non-infringing, provided that any substitute or modified item must meet all the requirements and be subject to all the provisions of this Agreement and the approval of the City. The terms and provisions of this Section shall survive the termination or expiration of this Agreement.

3.14 Personnel.

(a) *Adequate Staffing.* The Contractor must assign and maintain an adequate staff of competent personnel that is fully equipped, licensed as appropriate, available as needed, qualified and assigned to perform the Work. The Contractor must include among its staff the Key Personnel described below. The level of staffing may be revised from time to time with advance notice to the Project Manager.

(b) *Key Personnel.* “**Key Personnel**” means those persons assigned to those positions (in accordance with this Section), set forth in Exhibit 7. The Project Manager may at any time in writing notify the Contractor that the City will no longer accept performance of Work under this Agreement by one or more Key Personnel. Upon such a notice, the Contractor must immediately suspend the services of such Key Personnel and must replace such Key Personnel in accordance with the terms of this Agreement. In addition, the Contractor may remove Key Personnel from time to time, so long as the Contractor uses all reasonable efforts to maintain continuity in the Key Personnel

during the term of this Agreement. The City has the right to approve in writing the replacement for any Key Personnel, regardless of the reason for replacement, which approval will not be unreasonably withheld. At least one of the Key Personnel must be available by telephone or pager (at the numbers set forth in Exhibit 7) 24 hours a day, seven days a week. In addition, the Contractor must have Key Personnel within the City of Chicago on the days and at the times set forth in the schedule of availability that is attached hereto as Exhibit 7.

(c) *Chicago Office.* The Contractor must maintain an adequately staffed business office within the City of Chicago in order to facilitate contact between the Contractor and the City. Such office must be equipped as necessary to accept and respond to questions, concerns, complaints and reports relating to the Street Furniture. Key Personnel with an asterisk beside their name in Exhibit 7 must be based in the office in the City of Chicago.

(d) *Benefits.* The Contractor and Subcontractors are solely responsible for the compensation, benefits, contributions and taxes, if any, of all of their employees including, with respect to the Contractor, the Key Personnel. The Contractor and Subcontractors must at their own expense comply with all applicable workers' compensation, unemployment insurance, employer's liability, tax withholding, minimum wages and hours, and other Laws.

(e) *Responsibility.* The Contractor is financially and otherwise responsible to the City, the CPD and the CTA for acts and omissions of the Contractor, Subcontractors, their respective agents and employees, and any other persons performing portions of the Work, or claiming by, through or under the Contractor, and is financially and otherwise responsible to the City, the CPD and the CTA for any Losses resulting from such acts or omissions.

3.15 Minority and Women's Business Enterprises Commitment. In the performance of this Agreement, including the procurement and lease of materials or equipment, the Contractor must abide by the minority and women's business enterprise commitment requirements of the Municipal Code of Chicago, ch. 2-92, Sections 2-92-420 *et seq.* (1990), except to the extent waived by the Chief Procurement Officer. No later than October 1, 2002, the Contractor must submit Schedules C-1 and D-1 to the Chief Procurement Officer evidencing its compliance with this requirement with respect to the fabrication and installation of the Street Furniture for the period beginning on October 1, 2002 and ending on March 31, 2003. Commencing on January 1, 2003 and thereafter, the Contractor must submit completed Schedules C-1 and D-1 to the Chief Procurement Officer, evidencing its compliance with this requirement with respect to fabrication and installation of the Street Furniture on each January 1 and July 1 while fabrication and installation is still being performed by the Contractor. Schedules C-1 and D-1 submitted on each January 1 must evidence compliance with this requirement during the period beginning on the succeeding April 1 and ending on the succeeding September 30, and Schedules C-1 and D-1 submitted on each July 1 must evidence compliance with this requirement during the period beginning on the succeeding October 1 and ending on the succeeding March 31. Such Schedules C-1 and D-1 will be deemed automatically incorporated into this Agreement in Exhibit 3 upon acceptance by the Chief Procurement Officer. In addition, the Contractor must submit to the Chief Procurement Officer additional Schedules C-1

and D-1 relating to the maintenance and removal of the Street Furniture no later than the date the Contractor installs the first piece of Street Furniture, which Schedules C-1 and D-1 will be updated and resubmitted to the Chief Procurement Officer no less than every three months thereafter throughout the term of this Agreement. Such Schedules C-1 and D-1 will be deemed automatically incorporated into this Agreement in Exhibit 3 upon acceptance by the Chief Procurement Officer. Failure by the Contractor to submit Schedules C-1 and D-1, as required by this Section 3.15, constitutes an event of default by the Contractor pursuant to Article 12 of this Agreement. During the fabrication and installation of the Street Furniture during Phases I and II, the Contractor must utilize minority and women's business enterprises in percentages equal to or exceeding the greater of the percentages set forth in the applicable Schedules C-1 and D-1 or 31 percent and 6 percent, respectively, as applied to all costs of fabrication and installation of Street Furniture incurred by the Contractor in the performance of this Agreement. For purposes of the Special Conditions Regarding Minority Business Enterprise Commitment and Women's Business Enterprise Commitment, "**Total Contract Price**" means, with respect to the fabrication and installation of Street Furniture, all costs incurred by the Contractor in the fabrication and installation of Street Furniture pursuant to this Agreement. During the maintenance and removal of the Street Furniture, the Contractor must utilize minority and women's business enterprises in percentages equal to or exceeding the greater of the percentages set forth in the applicable Schedules C-1 and D-1 or 31 percent and 6 percent, respectively, as applied to all Out-Sourced Costs of maintenance and removal of Street Furniture incurred by the Contractor in the performance of this Agreement. For purposes of the Special Conditions Regarding Minority Business Enterprise Commitment and Women's Business Enterprise Commitment, "**Total Contract Price**" means, with respect to the maintenance and removal of Street Furniture, all Out-Sourced Costs incurred by the Contractor in the maintenance and removal of Street Furniture pursuant to this Agreement. "**Out-Sourced Costs**" means all costs incurred by the Contractor in its performance of the Work, excluding costs of Work performed by employees of the Contractor or its affiliates.

3.16 Safety. The Contractor is responsible for initiating, maintaining and supervising comprehensive safety precautions and programs in connection with the performance of this Agreement, including, without limitation, appropriate precautions and programs for areas in and around the performance of the Work. The Contractor must erect and maintain, as required by existing conditions and the performance of this Agreement, all reasonable safeguards for safety and protection, including posting danger signs and other warnings against hazards, promulgating safety regulations, and notifying the public and owners and users of adjacent sites and utilities. The Contractor must promptly remedy damage and loss to property to the extent caused in whole or in part by the Contractor, a Subcontractor or anyone directly or indirectly employed by any of them, or by anyone for whose acts they may be liable. The foregoing obligations of the Contractor are in addition to the Contractor's indemnity obligations hereunder.

3.17 Assignments and Subcontracts.

(a) *Standards for Assignments and Subcontracts.*

- (i) Except as permitted in this Agreement, the Contractor must not assign, delegate, subcontract or otherwise transfer all or any part of its rights or obligations under this Agreement or any part of it, without the express written consent of the Chief Procurement Officer, which consent shall not be withheld arbitrarily or capriciously. The Contractor may not knowingly enter into a contract or arrangement with, or otherwise permit, any Subcontractor to perform any portion of the Work if such Subcontractor is barred or prohibited from contracting with the City or has been found to be nonresponsive by the Chief Procurement Officer. The absence of such a provision or written consent voids the attempted assignment, delegation, subcontracting or transfer and is of no effect as to the Work or this Agreement. No approvals given by the Chief Procurement Officer operate to relieve the Contractor of any of its obligations or liabilities under this Agreement.
- (ii) The City expressly reserves the right to assign or otherwise transfer all or any part of its interests under this Agreement to any successor.
- (iii) All subcontracts and all approvals of Subcontractors are, regardless of their form, considered conditioned upon performance by the Subcontractor in accordance with the terms and conditions of this Agreement. If any Subcontractor fails to observe or perform the terms and conditions of this Agreement to the satisfaction of the City, the City has the absolute right upon written notification to immediately rescind approval and to require the performance of this Agreement by the Contractor personally or through any other City-approved Subcontractor. Any approval for the use of Subcontractors in the performance of the Work under this Agreement under no circumstances operates to relieve the Contractor of any of its obligations or liabilities under this Agreement.
- (iv) Upon the request of the Chief Procurement Officer, the Contractor must furnish the Chief Procurement Officer with copies of its subcontract agreements with Subcontractors of the first tier. All subcontracts relating to Subcontractors of the first tier must contain provisions that (A) require the Work to be performed in strict accordance with the applicable requirements of this Agreement, (B) ensure the Subcontractors are subject to all applicable terms of this Agreement and (C) specify subcontracts are subject to the approval of the Chief Procurement Officer. If the agreements do not prejudice any of the City's rights under this Agreement, such agreements may contain different provisions than are provided in this Agreement with respect to

extensions of schedule, time of completion, payments, guarantees and matters not affecting the quality of the Work or Contractor's obligations to the City.

(b) *Third Party Beneficiaries.* Subcontractors are not third party beneficiaries of this Agreement, except as otherwise provided in the Municipal Code of Chicago, ch. 2-92, Sections 2-92-420 *et seq.* (1990), the Special Conditions Regarding Minority Business Enterprise Commitment and Women's Business Enterprise Commitment or the Payment and Performance Bond.

3.18 Warranty. The Contractor warrants to the City that all Work will be performed in accordance with generally accepted standards for each category of Work, that all Work provided under this Agreement will be performed in a good and workmanlike manner (including, without limitation, the fabrication and installation work, which must also be performed in accordance with sound construction practices), that all materials, supplies and equipment furnished under this Agreement will be of good quality and new (or like new, with respect to repairs and replacements), that the Work (including, without limitation, each item of equipment incorporated therein) will be of good and workmanlike quality and free from faults, defects and deficiencies, and that the Work will conform with the requirements of this Agreement. Prior to termination of this Agreement, the Contractor must immediately correct any failure to comply with this warranty or breach of this warranty (which corrective action must include, without limitation, any necessary removal, disassembly, reinstallation, repair, replacement, reassembly, reconstruction, retesting and/or reinspection of any part or portion of the Work), without cost to the City.

3.19 Payment and Performance Bond.

(a) *Amount of Bond and Obligations to be Covered.* The Contractor must deliver to the Chief Procurement Officer three payment and performance bonds (such bonds and all replacements thereof being collectively referred to herein as the "**Payment and Performance Bonds**") in the amounts described below, no later than the day the Contractor begins fabricating the Street Furniture, except as otherwise provided below with respect to the Removal Bond. Each Payment and Performance Bond shall cover and secure any and all claims made relating to Bonded Obligations while each such Payment and Performance Bond is in effect (prior to the applicable expiration date) and any other claims required to be covered by applicable Law.

- (i) The Payment and Performance Bonds must secure the faithful performance by the Contractor of all contractual obligations relating to the installation of the Street Furniture, maintenance and operation of the Street Furniture, removal and relocation of the Street Furniture, installation of additional pieces of Street Furniture requested by the City during the term of this Agreement, removal and dismantlement of the Street Furniture and restoration of all streets, sidewalks and curbs (as described in Section 4.3) affected by the removal of that Street Furniture upon the termination or expiration of this Agreement, whichever is earlier, and all other obligations of the Contractor pursuant to this Agreement (except as provided in the following sentence)

(collectively, the "**Bonded Obligations**"). The Payment and Performance Bonds shall not secure the Contractor's obligations to pay Contractor Fees or other payment obligations to the City; provided, however, that if the Contractor is in default of this Agreement as a result of a failure to pay Contractor Fees or other payment obligations to the City, the Payment and Performance Bonds shall continue to secure all Bonded Obligations of the Contractor pursuant to this Agreement and as may be otherwise provided by applicable Law, in the limits of such Payment and Performance Bonds, notwithstanding the occurrence and continuation of such default. The Contractor must maintain the Payment and Performance Bonds in effect during the entire term of the Agreement (except as otherwise expressly provided herein) and until the Contractor has satisfied all of its Bonded Obligations pursuant to this Agreement, including any such Bonded Obligations extending beyond the term of this Agreement.

- (ii) The Contractor must provide three separate Payment and Performance Bonds (except as otherwise expressly provided herein) to cover the Bonded Obligations, as follows:
 - (A) One Payment and Performance Bond in the amount of \$7,333,333 (the "**Installation Bond**") as security for the faithful performance by the Contractor of its obligations to install the Street Furniture, as provided in this Agreement. The Installation Bond shall expire on the earlier of (i) March 31, 2005, or (ii) the date of termination of this Agreement. If the Contractor has not successfully completed all obligations to install the Street Furniture, as provided in this Agreement, by December 31, 2004, the Contractor shall provide a replacement Installation Bond expiring on the earlier of: (i) the date by which the City has determined the Contractor should reasonably be able to complete installation of the Street Furniture or (ii) one year from its date of issuance. The Installation Bond shall continue to be replaced in this manner until the Contractor has successfully completed installation of the Street Furniture. Any replacement Installation Bond shall meet all requirements for replacement Maintenance and Removal Bonds described in Section 3.19(b) below.
 - (B) One Payment and Performance Bond in the amount of \$2,000,000 (the "**Maintenance Bond**") as security for the faithful performance by the Contractor of its obligations to maintain and operate the Street Furniture, remove and relocate the Street Furniture during the term of this Agreement and install additional pieces of Street Furniture requested by the City during the term of this Agreement, all as

provided in this Agreement. The Maintenance Bond must be replaced as provided in Section 3.19(b) below.

- (C) One Payment and Performance Bond in the amount of \$4,666,666 (the "**Removal Bond**") as security for the faithful performance by the Contractor of its obligations to remove and dismantle the Street Furniture and restore all streets, sidewalks and curbs (as described in Section 4.3) affected by the removal of that Street Furniture upon the termination or expiration of this Agreement, whichever is earlier, and all other Bonded Obligations (except to the extent any such Bonded Obligations are already covered by the Installation Bond or the Maintenance Bond, as reasonably determined by the City).
- (iii) The Payment and Performance Bonds must collectively secure all Bonded Obligations and must all be provided by the same surety, unless otherwise approved by the City.
- (iv) The Removal Bond may be provided by the Contractor in two increments, as described herein. First, the Contractor must provide the Removal Bond in an amount equal to at least 50 percent of the full Removal Bond amount (\$2,333,333) by October 1, 2002. Second, if the Contractor provides such a reduced Removal Bond, such Removal Bond must be increased to equal 100 percent of the required Removal Bond amount (\$4,666,666) by December 31, 2003. The Maintenance Bond must be replaced as provided in Section 3.19(b) below. The Contractor acknowledges and agrees that it must maintain at all times a Removal Bond which expires no less than nine months after the expiration date of the Installation Bond and Maintenance Bond then in effect.

(b) *Renewal of Payment and Performance Bonds.* The Payment and Performance Bonds must collectively secure the performance of all Bonded Obligations of the Contractor for a period of no less than one year and must cover all claims made relating to the Bonded Obligations of the Contractor during such period. In confirmation and furtherance of the foregoing, each replacement Payment and Performance Bond will cover any and all claims relating to Bonded Obligations made or arising during the term of such Payment and Performance Bond, regardless of when such claim accrues. No less than 90 days prior to the expiration of the period covered by the Maintenance Bond and the Removal Bond provided hereunder, the Contractor must deliver to the Chief Procurement Officer a replacement Maintenance Bond and Removal Bond covering at least the one-year period beginning on the date of the expiration of the period covered by the then-current Maintenance Bond and Removal Bonds. The replacement Maintenance Bond and Removal Bonds must be substantially identical to the Maintenance Bond or Removal Bonds being replaced (with the exception of the period covered by each Maintenance Bond or Removal Bond) and must be issued by a surety satisfying the requirements of this Section 3.19. In confirmation and furtherance of the foregoing, the Contractor must provide the Payment and Performance Bonds as described herein during the entire term of the

Agreement (except as otherwise provided herein with respect to the Installation Bond) and until the Contractor has satisfied all Bonded Obligations pursuant to this Agreement, including any such Bonded Obligations extending beyond the term of this Agreement. The last Installation Bond, Maintenance Bond and Removal Bond provided by the Contractor hereunder shall each cover all claims relating to Bonded Obligations made after the date of issuance of each such Bond, regardless of when such claim accrues (except to the extent limited by the terms of the applicable Payment and Performance Bond).

(c) *Requirements of Payment and Performance Bonds and Surety.*

- (i) The Payment and Performance Bonds provided by the Contractor must comply with the provisions of 30 ILCS 550/1 *et seq.*, as amended, and of Chapter 2, Section 2-92-030 of the Municipal Code of Chicago, as amended and be in such form as the bond form included in Exhibit 6. The surety issuing the Payment and Performance Bonds must meet all requirements under this Section 3.19 and applicable Law and must be acceptable to the City Comptroller in his reasonable discretion. The surety for the Payment and Performance Bonds must be listed in the most recently published (as of the date of issuance of the Payment and Performance Bonds) "Listing of Approved Sureties" of the U.S. Department of the Treasury, with underwriting limitations in excess of the total Payment and Performance Bonds amount.
- (ii) In case of neglect, failure, or refusal of the Contractor to provide a satisfactory surety and Payment and Performance Bonds by the date specified in Section 3.19(a), replace the Payment and Performance Bonds as required herein and maintain such surety and Payment and Performance Bonds in place until the Contractor has satisfied all Bonded Obligations pursuant to this Agreement (including any such Bonded Obligations extending beyond the term of this Agreement), the Chief Procurement Officer may declare the Contractor in default of this Agreement. The City will not require any payment or performance by the surety pursuant to the Payment and Performance Bonds solely by reason of any such default if the Contractor is continuing to perform all Bonded Obligations. Notwithstanding the foregoing, any such default will not release Contractor or its surety from any claim relating to a Bonded Obligation which may be made after the date of issuance of the Payment and Performance Bonds in effect at the time of the default.
- (iii) If at any time the surety upon the Payment and Performance Bonds becomes insolvent, or is, in the sole opinion of the Chief Procurement Officer, unsatisfactory, or unable to respond to damages in case of liability on such bond, the Chief Procurement Officer will notify the Contractor and direct that Payment and Performance Bonds issued by a satisfactory surety be provided forthwith.

- (iv) To the extent the Contractor has not provided satisfactory Payment and Performance Bonds as required herein because the Contractor is unable to obtain satisfactory Payment and Performance Bonds due to changed market conditions occurring after the Commencement Date, the Project Manager and the Contractor will use reasonable efforts to determine whether the City is legally authorized to accept alternate security from the Contractor to secure the Bonded Obligations, such as a letter of credit or similar liquidity facility. In such event, the Project Manager will use reasonable efforts to obtain the authorization of City Council, if necessary, to permit the City to accept such a form of alternate security. If the Contractor is unable to provide satisfactory Payment and Performance Bonds as required herein due to changed market conditions occurring after the Commencement Date, the Contractor must so notify the City on the earlier of (A) 5 days after being notified that the Contractor's surety will not provide or renew the Payment and Performance Bonds, and (B) 90 days prior the expiration of the then-current Payment and Performance Bonds.
- (v) The Payment and Performance Bonds (including each renewal thereof) must remain on deposit with the Chief Procurement Officer permanently. The fact that the Payment and Performance Bonds remain on deposit with the Chief Procurement Officer shall not expand the responsibilities of the surety beyond those described in this Agreement and in the Payment and Performance Bonds. It is understood and agreed that upon the expiration of any Installation Bond, Maintenance Bond, or Removal Bond all liability relating to claims not made while such bonds are in effect, including replacements, shall be released in full; provided, however, that, the liability under the last Installation Bond, Maintenance Bond, and Removal Bond provided by the Contractor hereunder shall expire as provided by applicable Law, the terms of such bonds and as otherwise provided in this Agreement.
- (d) *City's Rights.*
 - (i) The rights reserved to the City with respect to the Payment and Performance Bonds are in addition to all other rights reserved by the City pursuant to this Agreement or by Law, and no action, proceeding or right with respect to the Payment and Performance Bonds will affect any other legal rights, remedies or causes of action belonging to the City.
 - (ii) The City has the right, without legal proceedings, to claim against the surety under the Payment and Performance Bonds any amount due and owing for the payment of any money which may be due the City as a result of the Contractor's failure to perform the Work in accordance with this Agreement

(after allowing the surety any opportunity to cure permitted by the terms of the Payment and Performance Bonds).

- (iii) If the amount of the Payment and Performance Bonds is insufficient to cover any costs or damages to the City, the Contractor is liable for the shortfall and must pay such shortfall to the City upon demand.

3.20 Parent Guarantees. No later than the 10th day after the Commencement Date, the Contractor shall provide a guaranty of JCDecaux SA and a guaranty of JCDecaux North America, Inc. in the form attached hereto as Exhibit 12, with such changes as may be approved by the City. For each calendar year during the term of this Agreement, JCDecaux SA and JCDecaux North America, Inc. must each provide audited financial statements to the Project Manager not later than 180 days after the end of each calendar year. To the extent the City reasonably determines that JCDecaux SA or JCDecaux North America, Inc. has suffered a material adverse change in its financial condition, the City may require the Contractor to provide a letter of credit or similar security to cover the obligations secured by the guaranty of such entity or entities.

ARTICLE 4 COORDINATED STREET FURNITURE PROGRAM AND RELATED SERVICES

4.1 Design of Street Furniture.

(a) *Design.* The Contractor will provide Street Furniture designed in accordance with the design for the Street Furniture described on Exhibit 1A attached hereto.

(b) *Inspection by City.* Upon reasonable advance notice, the City shall have the right at its discretion (but not the obligation) to inspect the Plans and Specifications and similar items relating to the design of the Street Furniture during the design and engineering process. The Contractor must respond promptly to any concerns, questions or comments raised by the City. The City may reject defective Work in accordance with Section 3.7. The Contractor must give the City no less than 60 days' written notice prior to beginning manufacturing of each type of Street Furniture, and the City may request minor design changes relating to each type of Street Furniture until the Contractor begins manufacturing each such type, as specified in the notice. No inspection by the City shall operate to relieve the Contractor of any of its obligations or liabilities under this Agreement or give the City any liability or responsibility for the design of the Street Furniture, including any errors or omissions relating thereto.

(c) *Accessibility.* The Contractor warrants that all Street Furniture will comply with all Laws applicable to the Contractor and to the City regarding accessibility standards for disabled or environmentally limited persons, including but not limited to the following: Americans with Disabilities Act. (42 U.S.C. 12101 *et seq.*) and the Americans with Disabilities Act Accessibility Guidelines for Buildings and Facilities ("ADAAG"); The Architectural Barriers Act., P.L. 90-480 (1968) and the Uniform Federal Accessibility Standards ("UFAS"); and the Illinois Environmental

Barriers Act, 410 ILCS 25/1 *et seq.* (1989), and the regulations promulgated thereto at 71 Ill. Adm. Code Ch. 1, Sec. 400.110. In the event that the above cited standards are inconsistent, the Contractor warrants that the Street Furniture complies with the standard providing greater accessibility.

4.2 **Manufacture of Street Furniture.**

(a) *Inspection by City.* Upon reasonable advance notice, the City shall have the right at its discretion (but not the obligation) to inspect the Street Furniture during the manufacturing process. The Contractor must respond promptly to any concerns, questions or comments raised by the City. The City may reject defective Work in accordance with Section 3.7. No inspection by the City shall operate to relieve the Contractor of any of its obligations or liabilities under this Agreement or give the City any liability or responsibility for the manufacturing of the Street Furniture, including any errors or omissions relating thereto.

(b) *Assembly in City.* The Contractor must use all reasonable efforts to manufacture all Bus Stop Shelters, Bus Supervisor Kiosks, Multiple Newsracks and CIPs within the City of Chicago.

4.3 Dismantlement and Removal of Existing Street Furniture. As requested by the Project Manager, the Contractor must dismantle and/or remove existing bus stop shelters, bus supervisor shelters and newsstands being replaced by Street Furniture pursuant to this Agreement. The Contractor must coordinate and cooperate with the City and the CTA and must give to the City and, with respect to existing bus stop shelters and bus supervisor shelters, the CTA, written notice no less than 24 hours in advance of any dismantlement or removal in order to allow a reasonable opportunity for a representative of the City or the CTA to be present during any such dismantlement or removal. Prior to commencing any dismantlement or removal, the Contractor must make a record of the condition of each piece of existing street furniture, including any damage or defects, which record will be signed by a representative of the City or the CTA, if available. The Contractor will not be liable for any damage or defects identified on such record of condition (or damage directly resulting from such damage or defects), except to the extent such damage or defects (or damage directly resulting from such damage or defects) were caused by the Contractor or anyone for whom the Contractor is responsible or to the extent the Contractor is found liable for such damage or defects (or damage directly resulting from such damage or defects) by a court of competent jurisdiction. The CTA may choose to remove bus stop shelters and bus supervisor shelters after dismantlement by the Contractor. To the extent the CTA does not choose to remove existing street furniture, the Contractor must dispose of such existing street furniture or deliver such existing street furniture to a location as directed by the Project Manager in writing, which location shall be not further than 50 miles from the Central Business District. Once the Contractor has moved a piece of existing street furniture at the direction of the Project Manager, the Contractor will not be required to bear the cost of moving such piece again, if so directed. The Contractor will not be responsible for re-installing any such removed existing street furniture. The Contractor must perform the Work described in this Section in accordance with a schedule approved by the Project Manager and such Work must be performed at the Contractor's sole cost and expense. Existing bus stop shelters and bus supervisor shelters shall remain the sole property of the CTA after they have been dismantled and/or removed.

4.4 Installation of Street Furniture.

(a) *Site Selection and Installation Permits.*

- (i) The Contractor must install the Street Furniture at the sites identified in Exhibit 1B, as amended by the City from time to time.
- (ii) The Contractor may submit to the City in writing proposed sites for Bus Stop Shelters (in addition to those identified on Exhibit 1B as of the Commencement Date) and CIPs, which the City will consider adding to Exhibit 1B.
- (iii) The sites to be included in the Installation Permit Applications for the Initial Installation Permits are the first sites at which Street Furniture shall be installed and such sites are identified as the Initial Central Business District and Initial Chicago Neighborhoods sites on Exhibit 1B. If, pursuant to the terms of this Agreement, the City directs the Contractor not to install Street Furniture at any Initial CBD-A site listed on Exhibit 1B, the City must select a site from the sites identified as “CBD-A Alternates” on Exhibit 1B, to the extent such a site remains available on such list, and such additional site shall be deemed automatically included in the sites to be included in the Installation Permit Applications for the Initial Installation Permits. If, pursuant to the terms of this Agreement, the City directs the Contractor not to install Street Furniture at any Initial CBD-B site on Exhibit 1B, the City must select a site from the remaining sites identified as “CBD-B Alternates” on Exhibit 1B, to the extent such a site remains available on such list, and such additional site shall be deemed automatically included in the sites to be included in the Installation Permit Applications for the Initial Installation Permits. If, pursuant to the terms of this Agreement, the City directs the Contractor not to install Street Furniture at any Initial Chicago Neighborhoods site on Exhibit 1B, the City must select a site from the list identified as “Chicago Neighborhood Alternates” on Exhibit 1B, to the extent a site remains available on such list, and such additional site shall be deemed automatically included in the sites to be included in the Installation Permit Applications for the Initial Installation Permits. If alternate sites are not available as described in the preceding three sentences, the City shall select alternate sites in the manner described in Section 4.4(a)(iv). With regard to sites replaced with alternate sites pursuant to this Section 4.4(a)(iii), the Contractor will be entitled to an abatement in the Contractor Fees or the City will be entitled to an increase in the Contractor Fees only to the extent specifically described in Section 4.9(a)(iii).
- (iv) The Commissioner of DPD may identify sites for Bus Stop Shelters to be proposed to City Council for its authorization, if necessary, for addition to

Exhibit 1B. Upon such City Council authorization (or other authorization by the City, as required), such additional sites will be deemed automatically added to Exhibit 1B. In identifying Bus Stop Shelter sites to be proposed to City Council for addition to Exhibit 1B, the Commissioner of DPD will take into account the following considerations: (A) passenger density; (B) surrounding traffic flow; (C) passenger needs (including convenience and safety); (D) the smooth flow of traffic; (E) coordination with trees, light poles, traffic control and electrical boxes and other pieces of Street Furniture; (F) the needs of the Contractor; and (G) other factors deemed relevant by the Commissioner of DPD (collectively, the “**Site Selection Criteria**”). For purposes of the Site Selection Criteria, the needs of the Contractor include factors relevant to the ability to generate advertising revenue at such site. The considerations of passenger convenience and safety and the smooth flow of traffic will be paramount in the Commissioner of DPD’s identification of sites.

- (v) The Contractor will propose to the City sites for the CIPs and the City may accept or reject such sites in its sole discretion. The Contractor must propose such sites in good faith, considering the needs and interests of the City as well as those of the Contractor. The City and the Contractor will use all reasonable efforts to agree on sites within such time as will permit the City to issue Installation Permits for CIPs by the applicable Permit Issuance Dates (as defined below). Sites for CIPs will be added to Exhibit 1B when the City and the Contractor have agreed on such sites and such sites have been authorized by City Council, if necessary.
- (vi) The “**Site Selection Date**” for each piece of Street Furniture (excluding CIPs) shall be, with respect to pieces of Street Furniture for which locations were not identified in Exhibit 1B as of the Commencement Date, the date that is 210 days prior to the last day of the quarter in which the relevant piece of Street Furniture is to be installed, as identified in Exhibit 1C. The Project Manager shall endeavor to ensure that additional sites (i.e., those not identified in Exhibit 1B as of the Commencement Date) for installation of Street Furniture are added to Exhibit 1B (following identification by the Commissioner of DPD and authorization by the City Council, if necessary) no later than the applicable Site Selection Date.
- (vii) If there is a conflict between (i) the sites identified in Exhibit 1B and (ii) the provisions of the Municipal Code of Chicago, the June 9 Ordinance or any other City Ordinances, then the provisions of the Municipal Code of Chicago, the June 9 Ordinance or the other City Ordinances, as applicable, will govern.
- (viii) Prior to commencing installation of each piece of Street Furniture, the Contractor must obtain any applicable permits and approvals relating to such

piece of Street Furniture, including the Installation Permit. Prior to or at the time the Contractor files each Complete Installation Permit Application for a Bus Stop Shelter, the Contractor must notify the Project Manager in writing as to whether such Bus Stop Shelter will contain a fixed or a scrolling Ad Panel. If the Contractor does not so notify the Project Manager, such Bus Stop Shelter will be deemed to contain a fixed Ad Panel for the purposes of any abatement calculations relating to the City's failure to deliver an Installation Permit by the applicable Permit Installation Date.

- (ix) The "**Permit Application Date**" for each piece of Street Furniture (excluding CIPs and except as provided in Section 4.4(a)(xi) below) shall be the date that is 150 days prior to the last day of the quarter in which the relevant piece of Street Furniture is to be installed, as identified in Exhibit 1C. The applicable Permit Application Date for each Bus Stop Shelter shall be deemed automatically extended by one day for every one day late beyond the applicable Site Selection Date the City is in selecting a site for such Bus Stop Shelter. The Permit Application Date for each CIP shall be the date that is 60 days after the City and the Contractor have selected a site for a CIP and such site has been authorized by City Council, if necessary. The Contractor must endeavor to submit Complete Installation Permit Applications for all pieces of Street Furniture no later than the applicable Permit Application Dates.
- (x) The "**Permit Issuance Date**" for each piece of Street Furniture (excluding CIPs and except as provided in Section 4.4(a)(xi) below) shall be the date that is 90 days prior to the last day of the quarter in which the relevant piece of Street Furniture is to be installed, as identified in Exhibit 1C. The Permit Issuance Date for each CIP shall be the date that is 60 days prior to the last day of the quarter in which the relevant CIP is to be installed, as identified in Exhibit 1C. The applicable Permit Issuance Date(s) shall be deemed automatically extended by one day for every one day late the Contractor is in submitting Complete Installation Permit Application(s) beyond the applicable Permit Application Date. The Contractor acknowledges and agrees that its sole and exclusive remedy for the City's failure to issue an Installation Permit for any piece of Street Furniture is the remedy specifically described in Section 12.5(d).
- (xi) Notwithstanding anything to the contrary contained in this Section 4.4(a), the Permit Application Dates for the "Initial Central Business District" sites identified on Exhibit 1B are as follows: August 15, 2002 for the first 75 sites, September 1, 2002 for the next 75 sites and October 1, 2002 for the next 175 sites. The Permit Issuance Dates for the "Initial Central Business District" sites identified on Exhibit 1B are as follows: October 1, 2002 for the first 150 sites and November 1, 2002 for the next 175 sites. The Permit Application

Dates for the "Initial Chicago Neighborhoods" sites identified on Exhibit 1B are as follows: August 15, 2002 for the first 25 sites, September 1, 2002 for the next 25 sites and October 1, 2002 for the next 75 sites and November 1, 2002 for the next 200 sites. The Permit Issuance Dates for the "Initial Chicago Neighborhoods" sites identified on Exhibit 1B are as follows: October 1, 2002 for the first 50 sites, November 1, 2002 for the next 75 sites and December 1, 2002 for the next 200 sites.

(b) *Time for Installation.*

- (i) Upon receipt of Installation Permits, the Contractor must commence installation of the Street Furniture authorized by such permits in a manner that will ensure compliance with the Installation Schedule. The Contractor covenants and agrees that it will comply with the Installation Schedule, which schedule may only be adjusted as described in Section 12.5.
- (ii) The Contractor must not install more than one Bus Stop Shelter at a site identified in Exhibit 1B as an "Initial Central Business District" site for every one Bus Stop Shelter it installs at a site identified in Exhibit 1B as an "Initial Chicago Neighborhoods" site (except as otherwise provided herein). In confirmation and furtherance of the foregoing, the Contractor warrants and represents that it will install Bus Stop Shelters at "Initial Chicago Neighborhoods" sites at the same rate as the rate at which they are installed at the "Initial Central Business District" sites and at no time will there be more Bus Stop Shelters installed at "Initial Central Business District" sites than at "Initial Chicago Neighborhoods" sites. To the extent the City has not issued Installation Permits relating to the "Initial Chicago Neighborhoods" sites at such a rate as to enable the Contractor to comply with the requirements of this Section 4.4(b)(ii), and the Contractor has filed all Complete Installation Permit Applications relating to the "Initial Central Business District" sites and the "Initial Chicago Neighborhoods" sites no later than the applicable Permit Application Dates and the Contractor is otherwise not at fault, the Contractor will be excused from the requirements of this Section 4.4(b)(ii).
- (iii) The City shall, at the time of site selection, deliver notice to the Contractor specifying sites at which Multiple Newsracks must be installed, which notice shall identify the configuration of, and the publications to be vended from, each Multiple Newsrack. The Contractor must install Multiple Newsracks at intersections, as directed by the City, on the following streets (including the public way adjacent to both sides of the boundary streets): Randolph, Washington, Madison, Monroe and Adams Streets between Michigan Avenue and Wells Street; Michigan Avenue between Randolph Street and Oak Street; Chicago Avenue between Michigan Avenue and LaSalle Street; and Rush

Street between Chicago Avenue and Bellvue Place. The Contractor is required to install up to 110 Multiple Newsracks (exclusive of Multiple Newsracks installed pursuant to the Initial Multiple Newsrack Program) during the first ten Contract Years of the Agreement. Such Multiple Newsracks must be installed in four phases in accordance with the Installation Schedule.

(c) *Additional Street Furniture Sites.* The City may amend Exhibit 1B in accordance with Section 13.5 and the June 9 Ordinance in the manner provided by this Agreement.

(d) *Additional Bus Stop Shelters Locations.*

(i) Following the installation of the 2,175 Bus Stop Shelters required by this Agreement, the Contractor must install additional Bus Stop Shelters (each such additional Bus Stop Shelter (exclusive of any replacements and/or relocations of the initial 2,175 Bus Stop Shelters) beyond the initial 2,175 Bus Stop Shelters required by this Agreement being an “**Additional Shelter**”) at locations identified by the Commissioner of DPD and designated by City Council order from time to time, in accordance with the procedures described in Section 4.4(a)(iv). The Contractor must install Additional Shelters pursuant to this Section 4.4(d) as soon as reasonably possible (but in no event later than 180 days) after the effective date of the applicable City Council order. The Installation Schedule will be deemed automatically amended to reflect that any Additional Shelter must be installed no later than 180 days after the effective date of the applicable City Council order. Notwithstanding the foregoing, the Contractor will not be required to install more than 25 Additional Shelters per week pursuant to this Section 4.4(d) and, if the Contractor has submitted Complete Permit Installation Application(s) for an Additional Shelter(s) no later than 60 days after the effective date of the applicable City Council order, the Contractor will not be required to install any Additional Shelter pursuant to this Section 4.4(d) sooner than 60 days after the date of issuance of the applicable Installation Permit(s). Exhibit 1B will be deemed automatically amended to include any such Additional Shelters locations upon the effective date of the applicable City Council order. The City may in its sole discretion determine whether any Additional Shelter will be authorized to bear Ad Panels. If the City authorizes Ad Panels for an Additional Shelter, the Contractor may elect whether such Additional Shelter will bear Ad Panels. In the event any such Additional Shelter is relocated at any time, the Contractor will not be entitled to any abatement of Contractor Fees attributable to such relocation and the City will not be entitled to any increase in Contractor Fees attributable to such relocation.

- (ii) As of the date the Contractor has installed an Additional Shelter, the City will authorize the Contractor to abate from the Contractor Fees the Contractor's reasonable cost of providing such Additional Shelter to the City.
- (e) *Additional Multiple Newsrack Locations.*
- (i) During the installation of the initial 110 Multiple Newsracks pursuant to this Agreement, the Commissioner of DPD shall, in cooperation with the Commissioner of CDOT, solicit comments on the Multiple Newsracks from members of the public, community organizations and representatives of newspapers, including any task force organized for the purpose of evaluating or monitoring multiple newsrack programs, and shall consider such comments when evaluating the Multiple Newsracks provided pursuant to this Agreement. Based on such evaluations, the City may require the Contractor to remove or relocate Multiple Newsracks at any time upon 14 days' written notice from the City. In addition, following the installation of the 110 Multiple Newsracks required by this Agreement at the locations identified in Exhibit 1B, the Contractor must install additional Multiple Newsracks (each such additional Multiple Newsrack (exclusive of any replacements and/or relocations of the initial 110 Multiple Newsracks) beyond the initial 110 Multiple Newsracks required by this Agreement being an "Additional Newsrack") at locations identified by the Commissioner of DPD in multiple newsrack areas (as designated by the Commissioner of DPD). The Contractor must install Additional Newsracks pursuant to this Section 4.4(e) as soon as reasonably possible (but in no event later than 180 days) after the designation by the Commissioner of DPD. The Installation Schedule will be deemed automatically amended to reflect that any Additional Newsrack must be installed no later than 180 days after the designation by the Commissioner of DPD. Notwithstanding the foregoing, the Contractor will not be required to install more than ten Additional Newsracks per calendar year pursuant to this Section 4.4(e) and, if the Contractor has submitted Complete Permit Installation Application(s) for such Additional Newsrack(s) no later than 60 days after the designation by the Commissioner of DPD, the Contractor will not be required to install any Additional Newsrack pursuant to this Section 4.4(e) sooner than 60 days after the date of issuance of the applicable Installation Permit(s). Exhibit 1B will be deemed automatically amended to include any such Additional Newsrack locations upon the designation by the Commissioner of DPD.
 - (ii) As of the date the Contractor has installed an Additional Newsrack, the City will authorize the Contractor to abate from the Contractor Fees the Contractor's reasonable cost of providing such Additional Newsrack to the City.

(f) *Conditions of Installation.* All Street Furniture must be installed in conformity with the Installation Schedule and the requirements described in Exhibit 8. In addition to the permits referenced in Section 4.4(a)(viii) above, City Council authorization may be required prior to the installation of certain Street Furniture. The Contractor must also comply with Chapter 10-20 of the Municipal Code of Chicago and the following requirements regarding installation of Street Furniture:

- (i) If any Street Furniture is installed on special surfaces (e.g., buffed sidewalks, granite slabs, etc.), the special surface on which the Street Furniture is placed must be maintained and comport with the existing sidewalk adjacent to Street Furniture;
- (ii) All installation of Street Furniture in the Central Business District must occur between the hours of 8:00 p.m. and 6:00 a.m., unless otherwise approved in writing by the Commissioner of CDOT, or his designee;
- (iii) All installation of Street Furniture outside the Central Business District must occur between the hours of 9:30 a.m. and 3:00 p.m. on weekdays, unless otherwise approved in writing by the Commissioner of CDOT, or his designee;
- (iv) City permits are required for each installation location and permits are required for all equipment being used on the public way. The Contractor is responsible for obtaining such permits diligently and promptly, prior to installation of any piece of Street Furniture;
- (v) The installation of all Street Furniture must be in compliance with the Municipal Code of Chicago, all applicable CDOT and City Department of Buildings rules and regulations and all other applicable Laws, all as may be amended from time to time, and the June 9 Ordinance; and
- (vi) The installation of all Street Furniture on CPD property must be in compliance with all applicable CPD rules and regulations.

(g) *Inspection by City.* The City and the CTA shall have the right at their discretion (but not the obligation) at all times to inspect the Street Furniture during the installation process. The Contractor must respond promptly to any concerns, questions or comments raised by the City. Any comments the Contractor receives from the CTA shall be forwarded to the City promptly and the City shall determine whether the Contractor will take action on such comments, in the City's sole discretion. The City may reject defective Work in accordance with Section 3.7. No inspection by the City or the CTA shall operate to relieve the Contractor of any of its obligations or liabilities under this Agreement or give the City or the CTA any liability or responsibility for the installation of the Street Furniture, including any errors or omissions relating thereto.

(h) *Accessibility.* The Contractor warrants that all installation, removals or alteration undertaken by the Contractor under this Contract will be performed in accordance with all Laws applicable to the Contractor and to the City regarding accessibility standards for disabled or environmentally limited persons, including but not limited to the following: Americans with Disabilities Act. (42 U.S.C. 12101 *et seq.*) and the ADAAG; The Architectural Barriers Act., P.L. 90-480 (1968) and the UFAS; and the Illinois Environmental Barriers Act, 410 ILCS 25/1 *et seq.* (1989), and the regulations promulgated thereto at 71 Ill. Adm. Code Ch. 1, Sec. 400.110. In the event that the above cited standards are inconsistent, the Contractor warrants that it will comply with the standard providing greater accessibility. If the Contractor fails to comply with the foregoing standards, the Contractor must perform again at Contractor's expense all work required to be performed as a direct or indirect result of such failure.

(i) *Installation Proximate to Advertising Benches.* The Contractor acknowledges that the City has a contract with a vendor, and may enter into arrangements with the same or other vendors in the future, to provide benches on the streets throughout the City which carry advertising. To the extent the City directs the Contractor to install a piece of Street Furniture at a location at which an advertising bench is located, the Contractor must install such piece of Street Furniture adjacent to such advertising bench, space permitting, and the presence of such an advertising bench will not impact the site selection process described in Section 4.4(a)(iv). If space does not permit such installation, the Contractor must notify the City in writing. The Contractor will not be required to install a Bus Stop Shelter at a location which would result in an advertising bench being located within a Bus Stop Shelter. After July 31, 2003, the City will not enter into a contract or other arrangement with an advertising bench vendor which permits such vendor to install new or maintain existing advertising benches at locations at which pieces of Street Furniture (excluding Multiple Newsracks) are located, as of the date such a contract is executed.

4.5 Electricity for Street Furniture.

(a) *Provision of Electricity.* The Contractor must provide and install in each Bus Stop Shelter, Bus Supervisor Shelter, Café Kiosk, CIP and Newsstand all necessary wiring, infrastructure and connections to power sources in order to provide continuous and uninterrupted electricity in each such piece of Street Furniture. In order to minimize trenching on City streets, the Contractor may connect its bus stop shelters and CIPs to the closest City - designated street light controller box, subject to the Contractor's obtaining a permit in accordance with the Municipal Code of Chicago, which permit the City will not unreasonably withhold. The City will be responsible the cost of electricity for Bus Stop Shelters and CIPs. The cost of electricity for Bus Supervisor Shelters, Café Kiosks and Newsstand shall be the responsibility of the parties identified in Section 4.15.

(b) *Requirements for Electrical Work.* In performing electrical work pursuant to this Agreement, the Contractor must comply with all applicable Laws and requirements of the City, including without limitation, the following standards:

- (i) All electrical installation must meet all applicable standards of the City's Electrical Code.
- (ii) All electrical work must be performed by a licensed electrical contractor.
- (iii) Each piece of electrically-equipped Street Furniture must be fed from a ground-fault circuit interrupter-type circuit breaker (i.e., a GFCI circuit breaker).
- (iv) Proper grounding is required. Each piece of electrically-equipped Street Furniture with metal components must be grounded and bonded to a driven copper-clad steel ground rod.
- (v) Each piece of electrically-equipped Street Furniture must be equipped with a suitable means of disconnecting all current carrying conductors (hot conductors) and the disconnect switch (i.e., toggle switch) must be accessible and within sight of each unit.
- (vi) All light fixtures, outlets, timing devices, photo-cells and similar devices must be approved by Underwriters Laboratories or another certifying agency or authority reasonably acceptable to the city.
- (vii) All conduit must be properly sized for the relevant cable and all cable must be properly sized for the load.
- (viii) Conduit must be galvanized rigid steel and must be a minimum of 30 inches below grade.
- (ix) A cut-out box with breakers must be located between the load and the service and the Contractor must provide any additional appropriately-sized breakers reasonably required by the City.
- (x) All cable must be rated for outdoor and wet conditions and all cable must be color coded red for hot, white for neutral and green for grounded.
- (xi) The Contractor must become a member of the Department of Transportation, Board of the Underground.

4.6 Maintenance of Street Furniture.

(a) *Maintenance Standards.* Throughout the term of this Agreement, the Contractor must maintain the Street Furniture in good working order in accordance with the maintenance standards

set forth in Exhibit 1D. The City shall have no responsibility for maintenance or inspection of the Street Furniture.

(b) *Inspection by City.* The City and the CTA shall have the right at their discretion (but not the obligation) at all times to inspect the Street Furniture during the maintenance process. The Contractor must promptly respond to any concerns, questions or comments raised by the City. Any comments raised by the CTA shall be directed to the City and forwarded to the Contractor by the City, in the City's sole discretion. No inspection by the City or the CTA shall operate to relieve the Contractor of any of its obligations or liabilities under this Agreement or give the City or the CTA any liability or responsibility for the maintenance of the Street Furniture, including any errors or omissions relating thereto.

4.7 Advertising on Street Furniture.

(a) *Grant of Right.*

- (i) In consideration of the Contractor's performance of the Work and payment by the Contractor of the Contractor Fees, the City hereby grants to the Contractor the exclusive right following the Commencement Date and during the term of this Agreement to sell and place advertising on certain pieces of the Street Furniture, at locations to be authorized by the City in advance and subject to the terms of this Agreement and the June 9 Ordinance. To the extent not prohibited by Law, during the period beginning on the Commencement Date and ending on December 31, 2009, the City shall not authorize any party to place advertising in a format equal to or less than 55 square feet on the public way within the boundaries of the City of Chicago. The limitation set forth in the preceding sentence in no way limits the City's ability to authorize advertising on the public way that is in a format measuring more than 55 square feet, and also does not alter the City's ability to continue to authorize programs and advertising authorized by the City as of the Commencement Date (without regard to the size of the advertising), including, without limitation, the City's banner program, the City's advertising bench program (subject to the provisions of Section 4.4(i)), advertising placed or authorized to be placed by the CTA (including advertising panels at subway entrances) and the CPD, current or future sponsorship agreements between the City and the CTA and their respective sponsors (so long as such sponsorship agreements do not restrict the Contractor's advertising rights granted herein with respect to the Ad Panels), sponsorship agreements in effect as of the Commencement Date between the CPD and its sponsors and advertising on taxi cabs and other vehicles traveling in the public way. In addition, such limitation does not authorize the Contractor to place advertising on anything or in any location other than on the Ad Panels of the Street Furniture for which the City has explicitly authorized the Contractor to sell and place advertising.

In confirmation of the foregoing, the Contractor acknowledges and agrees that, with respect to Cafe Kiosks containing Ad Panels installed on CPD property (exclusive of sidewalks and roads along the perimeter of CPD property), the Contractor's ability to sell and place certain types of advertising on such Ad Panels is limited by any CPD sponsorship agreements in effect as of the Commencement Date (in addition to all other restrictions described herein).

- (ii) Beginning on January 1, 2010 and continuing until the termination or expiration of this Agreement, whichever is earlier, if the City desires to obtain additional bus stop shelters, bus supervisor kiosks, multiple newsracks, café kiosks, newsstands, CIPs or column kiosks (i.e., kiosks for the distribution of information by the City and its vendors and other licensees, limited food service or newspapers) that will bear advertising (in addition to the Street Furniture provided by the Contractor pursuant to this Agreement), the City shall issue a written notice to the Contractor. Such notice shall describe the additional pieces of street furniture desired by the City and the locations for such street furniture. Within 60 days of receipt of such a notice, the Contractor may submit a proposal to supply such additional pieces of street furniture to the City, which proposal shall specify the terms on which the Contractor will supply such street furniture and the proposed fees to be paid to the City in relation thereto. The Contractor will remain bound by such a proposal for 180 days after submission. Upon receipt of any such proposal, the City may: (A) accept such proposal in its sole discretion, in which case the City and the Contractor will enter into an amendment to this Agreement reflecting the terms of such proposal, or (B) reject such proposal if the Chief Procurement Officer reasonably determines that the terms of the proposal are not comparable to the terms of this Agreement, considering the number and types of pieces of Street Furniture being requested and the capital investment required to provide such pieces. If the City rejects such a proposal, or if the Contractor does not submit a proposal within 60 days of receipt of the notice from the City, the City may solicit bids, proposals or quotes from other vendors or contractors to supply the additional street furniture desired by the City and the City may include the terms of the Contractor's proposal as minimum terms which any bidders or proposers must meet. The Contractor will be deemed disqualified from responding to any such solicitation. If the City receives a bid, proposal or quote which, as determined by the Chief Procurement Officer in his sole discretion, is more favorable to the City than the Contractor's proposal, the City may accept such other bid, proposal or quote. Furthermore, the City may in its sole discretion reject all bids, proposals and quotes, including the Contractor's proposal, or the City may accept the Contractor's proposal at any time during the 180-day period for which such proposal is binding on the Contractor. At any time the City desires to obtain additional Street Furniture (in addition to the pieces of Street

Furniture contemplated by this Agreement as of the Commencement Date), the City may do so using the procedures outlined in this Section 4.7(a)(ii) or, with respect to additional Bus Stop Shelters or Multiple Newsracks, pursuant to Sections 4.4(d) and (e), in the City's sole discretion.

(b) *Placement of Advertising.*

- (i) The Contractor may only sell and place advertising on the Street Furniture as permitted by the June 9 Ordinance. In addition, the Contractor may only sell and place advertising on those pieces of Street Furniture identified as "approved for advertising" on Exhibit 1B attached hereto, as the same may be amended from time to time. Advertising must be placed on Street Furniture in such a manner as to not interfere with bus operator, pedestrian or motorist sight lines necessary for traffic safety and the safety of members of the public using Street Furniture.
- (ii) The Contractor may sell and place advertising on only one side of each CIP authorized pursuant to this Agreement. The Contractor may choose which side of a CIP shall contain an Ad Panel.
- (iii) The Contractor must install an electrically back-lit Ad Panel (either fixed or scrolling) on each Bus Stop Shelter. The Contractor in its discretion may select up to 300 Bus Stop Shelters on which it will not install an Ad Panel; provided, however, that such Bus Stop Shelters not containing Ad Panels must be distributed reasonably evenly throughout the City, with no more than 12 in each aldermanic ward.

(c) *Multiple Newsrack Advertising.* No later than the date on which the first Multiple Newsrack is to be installed pursuant to this Agreement (as set forth in Exhibit 1C), the Contractor must remove all advertising (other than that which identifies or displays publications that are offered in such Multiple Newsracks) from Multiple Newsracks installed pursuant to the Initial Multiple Newsrack Program Agreement. Beginning with the installation of Multiple Newsracks pursuant to this Agreement, and except as may be authorized by the City Council after the Commencement Date, no Multiple Newsracks installed on any public way in the City may display advertising (other than that which identifies or displays publications that are offered in such Multiple Newsracks). Notwithstanding the foregoing, if authorized by the City Council after the Commencement Date, the Contractor must display City Messages free of charge during the term of this Agreement on Ad Panels on the back of Multiple Newsracks.

(d) *Restrictions on Advertising.* The Contractor must adhere to its advertising policy attached hereto as Exhibit 11 when placing advertising on Ad Panels. In addition, the Contractor may not place advertising on Ad Panels that violates sponsorship agreements in effect as of the Commencement Date between the CPD and its sponsors. Subject only to the restrictions expressly

set forth in this Section 4.7(d), the Contractor has the right to make all decisions regarding the acceptance of advertising for the Street Furniture pursuant to its own advertising policy and goals, and shall be solely responsible for such decisions. The City, the CPD and the CTA will not participate in, interfere with, or try to influence any such advertising decisions in any way.

(e) *Change in Law Relating to Advertising.* The Contractor and the City agree that \$25 million of the Contractor Fees relate to the Contractor's ability to advertise alcoholic beverages on Ad Panels on the Street Furniture in accordance with applicable Law. If there is a Change in Law restricting or prohibiting the advertising of alcoholic beverages on the Street Furniture effective after the Commencement Date (beyond the restrictions set forth in the Contractor's advertising policy), the Contractor and the City must negotiate a reduction in the \$25 million portion of the Contractor Fees relating to alcohol advertising. Such a reduction must be proportionate to the amount of time remaining in the term of this Agreement and proportionate to the extent of the impact of the Change in Law on the Contractor's ability to advertise alcoholic beverages on Ad Panels. Following such negotiation, the parties will enter into an amendment to this Agreement.

(f) *City Messages.* The Contractor must accept City Messages for display free of charge during the term of this Agreement on Ad Panels on (i) Multiple Newsracks, to the extent authorized as described in Section 4.7(c) and, (ii) a minimum of one side of each CIP. Such spaces must be reserved at all times for the City and the Contractor may display other advertising in such spaces only with the prior written consent of the City. In addition, the Contractor must offer to the City spaces in unsold Ad Panels, and unsold advertising panels maintained by the Contractor in other areas in and around the City of Chicago (including shopping malls, except to the extent prohibited by the Contractor's contractual arrangements relating to such shopping malls), for display of City Messages free of charge. The Contractor may replace such City Messages (except those located on Multiple Newsracks and CIPs) with paid advertising upon two days' written notice to the City.

(g) *Bus Schedules, Maps and Related Information.* The Contractor must install and maintain bus schedules, maps and related information provided by the CTA or the City in a format no larger than 18 inches by 24 inches inside a protective coating in Bus Stop Shelters, as reasonably directed by the CTA or the City from time to time. The Contractor must monitor the condition of any such schedules, maps and related information and must notify the City if any such item should be replaced due to poor condition, vandalism, theft or similar condition. In such event, the CTA or the City may provide a replacement for installation by the Contractor.

(h) *New Technology.* Nothing in this Agreement shall prevent the Contractor from proposing and implementing new technologies for Street Furniture or advertising display, subject to the approval of the Chief Procurement Officer.

4.8 Removal of Street Furniture at Termination or Expiration of Agreement. No later than the date of termination or expiration of this Agreement, whichever is earlier, the Contractor must remove all advertising from all Street Furniture. As soon as reasonably possible and no later than nine months after the termination or expiration of this Agreement (except as provided below), the

Contractor must dismantle and remove all Street Furniture at the direction of the City and restore the underlying and surrounding property (including, without limitation, surrounding landscaping, sidewalks, curbs, pavement and utilities) to a condition at least as good as that in which such property existed prior to the installation of the Street Furniture, at the Contractor's sole cost and expense. Notwithstanding the foregoing, to the extent this Agreement is terminated by the City pursuant to Article 12, the City may opt to operate a street furniture program using the Street Furniture as described in Section 12.2(b)(viii) and, in such event, the Contractor will not remove or dismantle the Street Furniture. If the City exercises the option to operate a street furniture program using the Street Furniture, as soon as reasonably possible and no later than nine months after the expiration of the term of this Agreement in which this Agreement is terminated, the Contractor must dismantle and remove all Street Furniture at the direction of the City and restore the underlying and surrounding property as described in the first sentence of this Section 4.8, at the Contractor's sole cost and expense. In either case, the City may direct the Contractor to dismantle and remove the Street Furniture in phases or groups of pieces, at the discretion of the City. In addition, the Contractor must coordinate removal of the Street Furniture with installation of any new street furniture by a subsequent vendor authorized or retained by the City, as reasonably directed by the City. The Contractor acknowledges and agrees that all obligations of the Contractor relating to the Street Furniture will continue until the Contractor has dismantled and removed all Street Furniture and restored the underlying and other surrounding property affected by the Work, including, without limitation, the obligation to maintain the Street Furniture and underlying and surrounding areas in accordance with this Agreement.

4.9 Relocation of Street Furniture.

(a) *Relocation and Removal Initiated by the City.*

- (i) In the first 18 months following the Commencement Date, the City may in its sole discretion direct the Contractor to remove or relocate pursuant to this Section 4.9(a), at no cost to the City, up to 20 pieces of Street Furniture installed by the Contractor pursuant to this Agreement, plus five Multiple Newsracks installed by the Contractor pursuant to this Agreement. In each subsequent calendar year during the term of this Agreement, beginning with 2004, the City may also, in its sole discretion, direct the Contractor to remove or relocate, at no cost to the City, Street Furniture installed pursuant to this Agreement, provided the aggregate number of relocations and removals required by the City in each calendar year, pursuant to this Section 4.9(a), does not exceed an amount equal to one percent of the total number of pieces of Street Furniture installed prior to the first day of such calendar year, plus five Multiple Newsracks. Relocations or removals requested or initiated by the Contractor will not count against the numbers of relocations or removals the City is permitted to direct pursuant to this Section 4.9(a)(i).
- (ii) If the City directs the Contractor to remove a piece of Street Furniture which bears one or more Ad Panels and the City does not authorize the Contractor

to relocate such piece of Street Furniture for more than 60 days, the Contractor may abate the Contractor Fees owed to the City annually with respect to such piece of Street Furniture in an amount equal to the abatement described in Exhibit 2 for the type of Street Furniture removed and the location from which it was removed (CBD-A, CBD-B or the Chicago Neighborhoods), using the point value and the formula set forth in Exhibit 2. Such abatement shall be calculated beginning on the 60th day after removal and ending on the earlier of (A) the 60th day after the City has issued an Installation Permit for the relocation of such piece of Street Furniture, and (B) the date the Contractor actually reinstalls the piece of Street Furniture. Notwithstanding the foregoing, the Contractor acknowledges and agrees that it must submit a Complete Permit Installation Application with respect to any such piece of Street Furniture being relocated no later than 30 days following notification from the City that it has selected a relocation site to be submitted to City Council for authorization. If there are unusual and unexpected site conditions existing at such new site which will reasonably and necessarily delay the Contractor in filing a Complete Permit Installation Application with respect to such site, the Contractor will be entitled to a 30-day extension of the time frame described in the preceding sentence. If the Contractor does not submit the Complete Permit Installation Application within the time frame required by this Section 4.9(a)(ii), the Contractor will not be entitled to an abatement with respect to such piece of Street Furniture for each day the Contractor is late in submitting the relevant Complete Permit Installation Application.

- (iii) The Contractor will be entitled to an abatement in the Contractor Fees or the City will be entitled to an increase in the Contractor Fees if the City directs the Contractor to relocate a piece of Street Furniture bearing an Ad Panel to a new location only to the extent provided in this Section 4.9(a)(iii). In addition, the Contractor will be entitled to an abatement in the Contractor Fees or the City will be entitled to an increase in the Contractor Fees if the City does not issue an Initial Installation Permit for a piece of Street Furniture bearing an Ad Panel, which was to be located at a site identified in Exhibit 1B, and instead selects an alternate site not identified in Exhibit 1B pursuant to Section 4.4(a)(iii) (such selection of an alternate site being referred to as a "relocation" from the original site to the alternate site for the purposes of this Section 4.9(a)(iii) only), only to the extent provided in this Section 4.9(a)(iii). Any abatement or increase in the Contractor Fees authorized by this Section 4.9(a)(iii) will begin on the date of installation of the piece of Street Furniture at the new location and continue until the end of the term of this Agreement (unless such piece is removed and relocated again).
- (A) If the City directs the Contractor to relocate a piece of Street Furniture located within the CBD-A to a site within the CBD-A, the Contractor

will not be entitled to any abatement of Contractor Fees with respect to such piece of Street Furniture.

- (B) If the City directs the Contractor to relocate a piece of Street Furniture located within the CBD-B to a site within the CBD-B, the Contractor will not be entitled to any abatement of Contractor Fees with respect to such piece of Street Furniture.
- (C) If the City directs the Contractor to relocate a piece of Street Furniture located within the Chicago Neighborhoods to a comparable site (measured by reference to the Site Selection Criteria) within the Chicago Neighborhoods, the Contractor will not be entitled to any abatement of Contractor Fees with respect to such piece of Street Furniture.
- (D) If the City directs the Contractor to relocate a piece of Street Furniture located within the CBD-A to a site within the CBD-B or the Chicago Neighborhoods, the Contractor will be entitled to an annual abatement of Contractor Fees equal to the difference between the CBD-A abatement and the CBD-B or Chicago Neighborhoods abatement, as applicable, described in Exhibit 2 for the type of Street Furniture being relocated, using the point value system and the formula set forth in Exhibit 2. Such abatement will be calculated beginning on the date on which the Contractor has installed such piece of Street Furniture at the new site.
- (E) If the City directs the Contractor to relocate a piece of Street Furniture located within the CBD-B to a site within the Chicago Neighborhoods, the Contractor will be entitled to an annual abatement of Contractor Fees equal to the difference between the CBD-B abatement and the Chicago Neighborhoods abatement, described in Exhibit 2 for the type of Street Furniture being relocated, using the point value system and the formula set forth in Exhibit 2. Such abatement will be calculated beginning on the date on which the Contractor has installed such piece of Street Furniture at the new site.
- (F) If the City directs the Contractor to relocate a piece of Street Furniture located within the CBD-B to a site located in the CBD-A, the City will be entitled to an annual increase in the Contractor Fees equal to the difference between the CBD-A abatement and the CBD-B abatement described in Exhibit 2 for the type of Street Furniture being relocated, using the formula described in Exhibit 2. Such increase will

be calculated beginning on the date on which the Contractor has installed such piece of Street Furniture at the new site.

- (G) If the City directs the Contractor to relocate a piece of Street Furniture located within the Chicago Neighborhoods to a site located in the CBD-A or the CBD-B, the City will be entitled to an annual increase in the Contractor Fees equal to the difference between the CBD-A or CBD-B abatement, as applicable, and the Chicago Neighborhoods abatements described in Exhibit 2 for the type of Street Furniture being relocated, using the formula described in Exhibit 2. Such increase will be calculated beginning on the date on which the Contractor has installed such piece of Street Furniture at the new site.
- (iv) The Contractor will not be entitled to any abatement of Contractor Fees and the City will not be entitled to any increase in Contractor Fees with respect to any piece of Street Furniture that does not bear an Ad Panel.

(b) *Relocation Initiated by the Contractor.* The Contractor may, at its sole cost and expense, remove and relocate Multiple Newsracks that have suffered Substantial Damage, upon written notice to the City and receipt of the City's written consent, which consent the City may not unreasonably withhold. The Contractor acknowledges and agrees that the authorization of the City Council of the City may be required for any such relocation. The Contractor may remove and relocate other pieces of Street Furniture that have suffered more than two incidents of Substantial Damage within any one-year period, upon written notice to the City and receipt of the City's written consent, which consent the City may not unreasonably withhold, and all necessary authorization, including the authorization of the City Council (if required, as determined by the City).

4.10 Ownership of Street Furniture. All Street Furniture (including, without limitation, Multiple Newsracks installed pursuant to the Initial Multiple Newsrack Program) is at all times the exclusive property of the Contractor and the Contractor must have full responsibility therefor. The City, the CPD and the CTA do not have any ownership interest in, or installation or maintenance obligations with respect to, the Street Furniture pursuant to this Agreement.

4.11 Licensing Arrangements. The Contractor acknowledges and agrees that certain of the Street Furniture may be located on property that is owned by persons or entities other than the City, the CPD and the CTA. The Contractor is responsible for obtaining any necessary authority to locate Street Furniture on property, whether owned by private or public entities, but shall not be required to pay a fee (exclusive of applicable City fees and fees otherwise required by Law) for the privilege of locating Street Furniture on property not owned by the City. The City shall endeavor to cooperate with the Contractor in obtaining authority to locate Street Furniture on property not owned by the City.

4.12 Agreement to Supersede Initial Multiple Newsrack Program Agreement. The City and the Contractor acknowledge and agree that this Agreement supersedes the Initial Multiple Newsrack Program Agreement. As of the Commencement Date, the City and the Contractor agree that the Initial Multiple Newsrack Program Agreement is deemed terminated and of no further force or effect. The Contractor covenants and agrees that the Multiple Newsracks installed pursuant to the Initial Multiple Newsrack Program must stay in place (unless otherwise directed by the City) and shall be subject to the terms and conditions of this Agreement on and after the Commencement Date. Beginning no later than 180 days after the Commencement Date, and in accordance with the Installation Schedule, the Contractor must refurbish the Multiple Newsracks installed pursuant to the Initial Multiple Newsrack Program so as to replicate the finish of Multiple Newsracks installed pursuant to this Agreement.

4.13 Compliance with Settlement Agreement. The Contractor acknowledges that the City is a party to the Settlement Agreement and the Contractor further acknowledges that it has received a copy of the Settlement Agreement. The Contractor must cooperate with the City in its compliance with the Settlement Agreement and the Contractor must take no actions which would impair the City's ability to comply or cause the City to become noncompliant with the Settlement Agreement.

4.14 Space in Multiple Newsracks.

(a) *Provision of Multiple Newsracks.* At the direction of the City and subject to the terms of this Agreement, the Contractor must provide space in Multiple Newsracks at each intersection sufficient to accommodate the number of publications that had been distributed in single newsracks at the intersection at the time of the most recent survey (conducted by the Commissioner of CDOT) upon which the designation is based, as determined by the City, unless the Commissioner of CDOT determines that the requirements of the Municipal Code of Chicago, or the existence of Street Furniture or other physical limitations, prohibit such accommodation.

(b) *City's Indemnification.* The City will indemnify the Contractor from and against liabilities resulting from the Contractor's removal of individual newspaper and periodical vending machines in order to install Multiple Newsracks in accordance with the provisions of this Agreement, except to the extent such liabilities in any way arise out of or relate to the negligence or willful misconduct of the Contractor.

4.15 Vendors' and Bus Supervisors' Use of Street Furniture. With respect to Newsstands and Cafe Kiosks furnished by the Contractor pursuant to this Agreement, the Contractor must cooperate with and reasonably accommodate vendors to which the City or the CPD grants licenses or permits to vend from such Newsstands and Cafe Kiosks. The use by such vendors of the Newsstands and Cafe Kiosks shall not operate to relieve the Contractor of any of its obligations or liabilities under this Agreement. The Contractor will not be required to enter into contractual relationships with any such vendor. The CPD will, or will require all Cafe Kiosks vendors to, (i) maintain the interior of the Cafe Kiosks, (ii) refrain from damaging the exteriors or posting any advertising or other materials unrelated to the vendor's business on the exteriors of such Cafe Kiosks,

(iii) pay all taxes applicable to their use of the Cafe Kiosks, and (iv) refrain from interfering with site lines of any Contractor Ad Panels. Prior to installation of Newsstands, the City shall (by rule, regulation, permit requirements or other means) require Newsstand vendors to comply with the same requirements with respect to Newsstands as Café Kiosk vendors must comply with respect to Café Kiosks, as described in the preceding sentence. The City will require the CTA to (i) maintain the interior of the Bus Supervisor Shelters, (ii) refrain from posting any advertising or other materials on the exteriors of such Bus Supervisor Shelters (except that bus supervisors may post job-related material in an 18-inch by 24-inch space provided on the Bus Supervisor Shelters by the Contractor), and (iii) refrain from interfering with site lines of any Bus Supervisor Shelters, except as required for bus supervisors' performance of their job duties. Vendors vending from Cafe Kiosks will be responsible for the cost of all utilities used by such vendors in the Cafe Kiosks. The Contractor will be responsible for the cost of all electricity relating to the Newsstands. In addition, the Contractor must reasonably cooperate with bus supervisors using the Bus Supervisor Shelters and the Contractor will be responsible for the cost of all electricity relating to the Bus Supervisor Shelters.

ARTICLE 5 TERM OF PERFORMANCE

5.1 Term of Performance. This Agreement commences as of the Commencement Date and ends on December 31, 2012 unless sooner terminated or extended as provided herein.

5.2 Timeliness of Performance.

(a) *Contractor's Performance.* The Contractor must design, fabricate, install, maintain, operate, remove and dismantle the Street Furniture and maintain and restore the underlying and other surrounding property affected by the Work, or cause the Street Furniture to be designed, fabricated, installed, maintained, operated, removed and dismantled and cause the maintenance and restoration of the underlying and other surrounding property affected by the Work, and provide the Deliverables within the term and within the time limits required under this Agreement, including, without limitation, Exhibits 1C and 1D.

(b) *City, CPD and CTA Not Responsible for Delays.* Neither the Contractor nor the Contractor's agents, employees or subcontractors are entitled to any damages from the City, the CPD or the CTA, nor is any party entitled to be reimbursed by the City, the CPD or the CTA for damages, charges or other losses or expenses incurred by the Contractor by reason of delays or hindrances in the performance of the Work, whether or not caused by the City, the CPD or the CTA. This Section 5.2(b) does not affect the Contractor's rights with respect to abatements of Contractor Fees as specifically provided in this Agreement.

(c) *Liquidated Damages for Delay.* The City and the Contractor agree that it would be extremely difficult and impracticable under the presently known and anticipated facts and circumstances to ascertain and fix with precision the actual damages relating to public convenience and the aesthetic appeal of the City of Chicago would incur should the Contractor delay in installing

the Street Furniture beyond June 30, 2005 (the "**Installation Deadline**"), and accordingly the parties hereby agree that if the Contractor fails to install any piece of Street Furniture by the Installation Deadline (except to the extent such date has been extended pursuant to Section 12.5), the City shall be entitled to recover from the Contractor as liquidated damages for such delay, and not as a penalty, the sum of \$100 per day for each piece of Street Furniture that is required to be installed pursuant to this Agreement and is not installed by the Installation Deadline. The City and the Contractor agree that such liquidated damages are not a penalty, but instead are a good faith and reasonable estimate of the damages and loss the City would suffer in the event the Contractor fails to install any piece of Street Furniture by the Installation Deadline. The liquidated damages shall be due and payable by the Contractor to the City upon demand.

5.3 Agreement Extension Option. If the Chief Procurement Officer (or his designee) determines there has been Satisfactory Performance of this Agreement by the Contractor during the term of this Agreement, the Chief Procurement Officer shall extend the original term of this Agreement (as described in Section 5.1 above) for an additional five-year period under the same terms and conditions as those set forth in this original Agreement, except as otherwise provided in this Agreement, by notice in writing to the Contractor. In addition, if this Agreement is extended as provided in the preceding sentence and the Chief Procurement Officer (or his designee) determines there has been Satisfactory Performance of this Agreement by the Contractor during the extended term of this Agreement, the Chief Procurement Officer shall extend the extended term of this Agreement for an additional five-year period under the same terms and conditions as those set forth in this original Agreement, except as otherwise provided in this Agreement, by notice in writing to the Contractor. The Chief Procurement Officer may, in his sole discretion, extend the term of this Agreement as provided in this Section 5.3 even if he has determined there has not been Satisfactory Performance of this Agreement by the Contractor during the term of this Agreement. Under no circumstances shall the original term (as described in Section 5.1 above) of this Agreement be extended for more than two five-year periods. If applicable, the Chief Procurement Officer will notify the Contractor of any extension of this Agreement no less than six months prior to the date on which the Agreement is due to terminate. Upon receipt of such notice, the Contractor must provide to the Chief Procurement Officer within 30 days Payment and Performance Bonds acceptable to the City which satisfy the requirements of Section 3.19 and secure the performance of all then-remaining Bonded Obligations for a period of no less than one year (or as otherwise required pursuant to Section 3.19(a)(iii)) after the beginning of the extension period and cover all liabilities of the Contractor arising during such period, unless such Payment and Performance Bonds are already on deposit with the Chief Procurement Officer. If the Contractor does not provide the Payment and Performance Bonds required by the preceding sentence within such 30-day period, the Chief Procurement Officer may in his sole discretion revoke his decision to extend the term and may declare the Contractor in default of this Agreement. After notification by the Chief Procurement Officer of a decision to extend the term and receipt of the required Payment and Performance Bonds, this Agreement will be deemed amended to reflect such time extension.

ARTICLE 6
FEEES

6.1 Amounts Due City. The Contractor must make payments to the City as described in this Section 6.1 for the privilege of selling and maintaining advertisements pursuant to the coordinated Street Furniture program described in this Agreement. The Contractor's obligation to pay the Contractor Fees to the City as provided in this Section 6.1 is independent of the Contractor's obligation to perform the Work and is not affected by the types or quantities of Street Furniture that the Contractor actually designs, fabricates, installs, maintains, operates, removes or dismantles, except as expressly set forth in this Agreement. The Contractor's obligation to make such payments to the City through the end of the term in which this Agreement terminates or expires survives the expiration or termination of this Agreement, subject to the provisions of Section 12.2(b). No compensation will be paid by the City to the Contractor.

(a) *Contractor Fees.*

- (i) For each calendar year after 2002 during the term of this Agreement, the Contractor must pay the Contractor Fees to the City when due in accordance with the Contractor Fee Schedule attached hereto as Exhibit 2. Payments of Contractor Fees must be made annually, not later than December 1 of each calendar year to which such Contractor Fees relate, as described in Exhibit 2.
- (ii) The Contractor must pay the Contractor Fees to the City payable in calendar year 2002, as identified on the Contractor Fee Schedule attached hereto as Exhibit 2, in the manner described herein. If the City has issued 85 percent of the Initial Central Business District Initial Installation Permits by November 1, 2002, the Contractor must pay to the City 85 percent of the Contractor Fees payment due for calendar year 2002 (the "Initial Fee") on November 1, 2002. If the City has issued more than 85 percent of the Initial Central Business District Initial Installation Permits by November 1, 2002, the Contractor must pay to the City on November 1, 2002 a percentage of the Initial Fee equal to the percentage of Initial Central Business District Initial Installation Permits issued by the City. If the City has not issued 85% of the Initial Central Business District Initial Installation Permits by November 1, 2002, the Contractor must pay to the City 85 percent of the Initial Fee when the City has issued 85 percent of the Initial Central Business District Initial Installation Permits. Thereafter, the Contractor must pay to the City the amount which would bring the total amount of the Initial Fee paid to such time to 95 percent when the City has issued 99 percent of the Initial Central Business District Initial Installation Permits and the Contractor must pay to the City the final five percent of the Initial Fee when the City has issued 100 percent of the Initial Central Business District Initial Installation Permits. If the City has not issued one or more Initial Central Business District Initial Installation Permits

by November 1, 2002 because the Contractor did not submit Completed Installation Permit Applications for such Initial Central Business District Initial Installation Permits in accordance with the requirements of this Agreement, such Initial Central Business District Initial Installation Permits shall be deemed issued by the City prior to November 1, 2002 for the sole purpose of the payment of the Initial Fee pursuant to this Section 6.1(a)(ii).

(b) *Fee Abatements.* The City shall reasonably determine in writing in each calendar year during the term of this Agreement, in accordance with the terms of this Agreement, whether Contractor Fees shall be abated for such calendar year. Any amount of abatement of the Contractor Fees, as determined by the City, with respect to a particular calendar year may be withheld by the Contractor from the Contractor Fees due to the City on December 1 of such year. Notwithstanding the foregoing, if the City has notified the Contractor in writing no later than October 1 of any year (except for the final calendar year of the term of this Agreement, as extended pursuant to Section 5.3, if at all) that the City has already appropriated the portion of the Contractor Fees to be abated in such calendar year, the City may direct the Contractor to instead withhold amounts to be abated for such calendar year from Contractor Fees payable in the following calendar year. The City may not so direct the Contractor in the final calendar year of the term of this Agreement, as extended pursuant to Section 5.3, if at all. The Contractor will be entitled to abate all abatements (as reasonably determined by the City in writing) for the last calendar year of the term of this Agreement, as extended pursuant to Section 5.3, if at all, from the Contractor Fees payable by the Contractor in such final year of the term. The Contractor acknowledges and agrees that the City has not made, and does not intend to make, any appropriations in relation to this Agreement.

6.2 Method of Payment. All payments due from the Contractor hereunder must be made by cashier's check delivered to the City's Office of Budget Management (attention: Director of Capital Programs) or by other method of payment approved in advance in writing by the City's Office of Budget Management.

6.3 Late Payments. Any late payments by the Contractor will bear interest, beginning on the day after the date on which the payment was due, at a rate per annum equal to the six-month United States Treasury Bill rate in effect as of the first day of the calendar year to which such late payment relates, plus two percent.

ARTICLE 7 DISPUTES

7.1 Dispute Resolution.

(a) *Presentation of Disputes to Chief Procurement Officer.* Except as otherwise provided in this Agreement, the Contractor must, and CDOT and DPD may, bring any dispute concerning a question of fact arising under this Agreement, which is not otherwise disposed of, to the Chief Procurement Officer. The Chief Procurement Officer shall make a decision regarding the appropriate

resolution of the dispute after a hearing based upon written submissions of the parties. The Chief Procurement Officer will reduce his or her decision to writing and mail or otherwise furnish a copy of it to the Contractor. The decision of the Chief Procurement Officer is final and binding.

(b) *Prerequisite to Appeal.* The Contractor must follow the procedures set out in this Article 7 and receive the Chief Procurement Officer's final decision as a condition precedent to filing an appeal of the decision to the Circuit Court of Cook County or any other court.

ARTICLE 8 INSURANCE

8.1 Insurance.

(a) *Insurance Limits.* The Contractor must provide and maintain at the Contractor's own expense, during the term of this Agreement and during any time period following the expiration or termination of the Agreement if the Contractor is required to return and perform any additional Work, the insurance coverages and requirements specified below insuring all operations related to this Agreement. All such insurance policies must indicate that as respects the insureds (whether named or otherwise), cross-liability and severability of interests must exist for all coverages provided thereunder.

- (i) Workers' Compensation and Employers' Liability. Workers' Compensation Insurance, as prescribed by applicable Law and covering all employees who are to provide a service under this Agreement, and Employers Liability coverage with limits of not less than \$100,000 for each accident or illness.
- (ii) Commercial General Liability (Primary and Umbrella). Commercial General Liability Insurance or equivalent with limits of not less than \$5,000,000 per occurrence for bodily injury, personal injury, and property damage liability. Coverage must include the following: All premises and operations, products/completed operations (for a minimum of two years following the end of the term of this Agreement, as extended, if at all), explosion, collapse, underground, separation of insureds, defense, and contractual liability (with no limitation endorsement). The City, the CTA and the CPD must be named as additional insureds on a primary, non-contributory basis for any liability arising directly or indirectly from the Work.
- (iii) Automobile Liability (Primary and Umbrella). When any motor vehicles (owned, non-owned and hired) are used in connection with work to be performed, the Contractor must provide Automobile Liability Insurance with limits of not less than \$1,000,000 per occurrence for bodily injury and property damage.

- (iv) Professional Liability. When any architects, engineers, construction managers or other professional consultants perform work in connection with this Agreement, Professional Liability Insurance covering acts, errors or omissions must be maintained with limits of not less than \$1,000,000. Coverage must include contractual liability. When policies are renewed or replaced, the policy retroactive date must coincide with, or precede, start of work on this Agreement. A claims-made policy which is not renewed or replaced must have an extended reporting period of two years.
- (v) Property Insurance/Installation Floater. All Risk Property Insurance, at replacement cost, for all loss or damage to any structure, machinery, equipment, building materials or supplies, being used with and during the course of fabrication, installation, maintenance and operation of the Street Furniture.
- (vi) Railroad Protection Liability Insurance. When any Work is to be done adjacent to or on railroad or transit property, the Contractor must provide, with respect to the operations that the Contractor or Subcontractors perform, Railroad Protective Liability Insurance in the name of the railroad or transit entity. The policy must have limits of not less than \$2,000,000 per occurrence and \$6,000,000 in the aggregate for losses arising out of injuries to or death of all persons, and for damage to or destruction of property, including the loss of use thereof.
- (b) *Loss or Damage to Personal Property*. The Contractor is responsible for all loss or damage to personal property (including but not limited to material, equipment, tools and supplies), owned, used, leased or rented by the Contractor.
- (c) *Additional Insurance Requirements*.
- (i) The Contractor must furnish to the City of Chicago, Department of Procurement Services, City Hall, Room 403, 121 North LaSalle Street, Chicago, Illinois 60602, original Certificates of Insurance, or such similar evidence, to be in force on the Commencement Date, and Renewal Certificates of Insurance, or such similar evidence, if the coverages have an expiration or renewal date occurring during the term of this Agreement. The Contractor must submit evidence of insurance on the City of Chicago Insurance Certificate Form (a copy of which is attached hereto as Exhibit 5) or equivalent prior to the award of this Agreement. The receipt of any certificate does not constitute agreement by the City that the insurance requirements in this Agreement have been fully met or that the insurance policies indicated on the certificate are in compliance with all requirements of this Agreement. The failure of the City to obtain certificates or other insurance evidence from

Contractor is not a waiver by the City of any requirements for the Contractor to obtain and maintain the specified coverages. The Contractor must advise all insurers of the provisions of this Agreement regarding insurance. Non-conforming insurance does not relieve Contractor of the obligation to provide insurance as specified herein. Nonfulfillment of the insurance conditions may constitute a violation of this Agreement, and the City retains the right to stop work until proper evidence of insurance is provided, or this Agreement may be terminated.

- (ii) The Contractor must submit certified copies of the commercial general liability railroad protection liability policies, and renewal policies, if the coverages have an expiration or renewal date occurring during the term of this Agreement, to the Chicago Transit Authority, ATTN: Manager of Benefits, Room 750, Merchandise Mart Plaza, P.O. Box 3555, Chicago 60654-0554. An insurance binder will be accepted until such time the policy is submitted.
- (iii) The insurance must provide for 60 days' prior written notice to be given to the City in the event coverage is substantially changed, canceled, or non-renewed.
- (iv) Any deductibles or self-insured retentions on referenced insurance coverages must be borne by Contractor.
- (v) The Contractor agrees that insurers waive their rights of subrogation against the City, its employees, elected officials, agents, or representatives.
- (vi) The insurance coverages and limits furnished by Contractor in no way limit the Contractor's liabilities and responsibilities specified within this Agreement or by Law.
- (vii) Any insurance or self-insurance programs maintained by the City do not contribute with insurance provided by the Contractor under this Agreement.
- (viii) The required insurance to be carried is not limited by any limitations expressed in the indemnification language in this Agreement or any limitation placed on the indemnity in this Agreement given as a matter of law.
- (ix) The Contractor must require all Subcontractors to provide the insurance required herein, or the Contractor may provide the coverages for such Subcontractors. All Subcontractors are subject to the same insurance requirements of the Contractor unless otherwise specified in this Agreement.
- (x) If the Contractor or a Subcontractor desire additional coverage, the party desiring the additional coverage is responsible for the acquisition and cost.

- (xi) The City Risk Management Department maintains the right to modify, delete, alter or change these requirements.

ARTICLE 9 INDEMNIFICATION

9.1 Contractor's Indemnification.

(a) *Obligation.* The Contractor must defend, indemnify, keep and hold harmless the Indemnitees (as defined below) from and against any and all Losses, including those related to:

- (i) injury, death or damage of or to any person or property;
- (ii) any infringement or violation of any property right;
- (iii) failure to pay or perform or cause to be paid or performed the Contractor's covenants and obligations as and when required under this Agreement or otherwise to pay or perform its obligations to any Subcontractor;
- (iv) the City's exercise of its rights and remedies under Section 12.2 of this Agreement; and
- (v) injuries to or the death of any employee of the Contractor or any Subcontractor under any workers' compensation statute.

(b) *Indemnitees and Losses.* "**Indemnitees**" means, collectively, the City, the CPD, the CTA and their respective officers, representatives, elected and appointed officials, agents and employees. "**Losses**" means, individually and collectively, liabilities of every kind, including losses, damages and reasonable costs, payments and expenses (such as, but not limited to, court costs and reasonable attorneys' fees and disbursements), claims, demands, actions, suits, proceedings, judgments or settlements, any or all of which in any way arise out of or relate to the acts or omissions of the Contractor, its employees, agents and Subcontractors:

(c) *Defense of Suits.* At the City Corporation Counsel's option, the Contractor must defend all suits brought upon all such Losses against the City, the CPD or the CTA and must pay all costs and expenses incidental to them, but the City has the right, at its option, to participate, at its own cost, in the defense of any suit, without relieving the Contractor of any of its obligations under this Agreement. Any settlement must be made only with the prior written consent of the City Corporation Counsel, the General Counsel of the CPD or the General Counsel of the CTA if the settlement requires any action on the part of the City, the CPD or the CTA, respectively.

(d) *Waiver of Limitation.* To the extent permissible by Law, the Contractor waives any limits to the amount of its obligations to indemnify, defend or contribute to any sums due under any

Losses, including any claim by any employee of the Contractor that may be subject to the Workers Compensation Act, 820 ILCS 305/1 *et seq.* or any other related Law or judicial decision (such as *Kotecki v. Cyclops Welding Corporation*, 146 Ill. 2d 155 (1991)). The City, however, does not waive any limitations it may have on its liability under the Illinois Workers' Compensation Act, the Illinois Pension Code or any other statute.

(e) *Admiralty Waiver.* The Contractor waives the right to receive the benefits of or to invoke the protection afforded by any and all maritime statutory limitations of liability, including the Limitation of Vessel Owner's Liability Act, 48 U.S.C. § 183 *et seq.*, that could act to diminish the liability of the Contractor for any harm or damage arising from Contractor's performance of its obligations under this Agreement in any manner or for any and all claims or other costs arising from or occasioned by its operations on any waterways, including Lake Michigan, the Chicago River, and the Calumet River. This provision is not intended to avoid or waive federal jurisdiction under the applicable admiralty Laws. This waiver extends only to the Indemnitees, and not to third parties seeking recovery for claims solely against the Contractor. Without limiting its waiver, the Contractor specifically consents to pay any and all sums in respect of any claims against the Indemnitees and other costs suffered by the Indemnitees arising from or occasioned by Contractor's operations in or on waterways, including the following:

- (i) Loss or damage to any other ship, vessel or boat caused proximately or otherwise by the Contractor's vessel, or loss of the cargo or other ship, vessel or boat;
- (ii) Loss of life or personal injury, or for any cost of life salvage;
- (iii) Loss or damage to any harbor, dock, building, graving or otherwise, slipway, pontoon, pier, quay, tunnel, jetty, stage, buoy, cables of any kind, or other fixed or movable object or property whatsoever;
- (iv) The cost of the removal, raising or destruction of the wreck of any vessel employed by the Contractor in performing its obligations under this Agreement;
- (v) If a vessel is disabled or otherwise, the cost of towage or other salvage of any vessel employed by the Contractor in performing its obligations under this Agreement;
- (vi) Loss or damage to the bottom, banks, or shoreline of the waterway.

(f) *Construction.* The provisions of this Article 9 will not be construed in a manner that would violate the Illinois Construction Contract Indemnification for Negligence Act, 740 ILCS 35/1 *et seq.*

(g) *Survival.* The provisions in this Article 9 survive expiration or termination of this Agreement for matters occurring or arising while this Agreement is in effect or as the result of or during the Contractor's performance of Work beyond the term of this Agreement. The Contractor acknowledges that the requirements set forth in this section to indemnify, keep and save harmless and defend the City are apart from and not limited by the Contractor's duties under this Agreement, including the insurance requirements under Article 8.

ARTICLE 10 COMPLIANCE WITH LEGAL REQUIREMENTS

10.1 General.

(a) *Compliance with Laws.* The Contractor must comply with all applicable Laws in its performance of the Work, including, without limitation, Laws prohibiting discrimination against individuals and groups. Notwithstanding anything in this Agreement to the contrary, references to a Law are considered to be a reference to (i) the Law as it may be amended from time to time; (ii) all regulations and rules pertaining to or promulgated pursuant to the Law; and (iii) all future Laws pertaining to the same or similar subject matter.

(b) *Taxes.* The Contractor will not receive any abatement of Contractor Fees for, and must pay, all applicable existing and future sales, consumer, use, excise, value added, real estate, transaction, nontitled use, employers' expense and other taxes, duties and tariffs (whether direct or indirect), including, without limitation, all duties, tariffs and taxes (whether foreign or otherwise) related to the import or export of machinery, equipment, materials and supplies. The parties agree that this Agreement does not convey, and the Contractor shall not have, any interest in any real estate owned by the City other than a mere right to place Street Furniture at the locations designated by the City pursuant to this Agreement, subject to the right of the City to relocate pieces of Street Furniture as set forth in this Agreement. The Contractor Fees shall not be construed as "rent" for any interest in real estate and the Contractor shall not as a result of such payments acquire any leasehold or other interest in City real estate. If the Street Furniture becomes subject to any state or local real estate tax, then the Contractor will be responsible for paying such tax as required and the Contractor will be granted an abatement in the Contractor Fees payable to the City in each calendar year equal to the amount of such tax actually paid by the Contractor in each such calendar year (to be abated as described in Section 6.1(b)). In addition, to the extent the City imposes after the Commencement Date a tax or other charge on the Contractor applicable to the Street Furniture or performance of the Work that is not generally applicable to businesses within the City, the Contractor will be granted an abatement in the Contractor Fees payable to the City in each calendar year equal to the amount of such tax or charge actually paid by the Contractor in each such calendar year (to be abated as described in Section 6.1(b)). In such event, the Contractor must provide written evidence satisfactory to the City of the payment of such tax or charge.

(c) *Licenses and Authorizations.* The Contractor must observe and comply with, and must cause its Subcontractors to observe and comply with, and obtain all licenses, certificates and other

authorizations required by all applicable Laws and must give all notices pertaining thereto. The Contractor must obtain all necessary rights of entry from the CPD and the CTA prior to performing work on CPD or CTA property, as applicable.

(d) *Disclosure Affidavit.* The Contractor must execute and must cause all Subcontractors of the first tier (and other Subcontractors as may be required by applicable Law) to execute a Disclosure Affidavit (including disclosure of retained parties) in the form attached to this Agreement as Exhibit 4.

10.2 Federal Requirements.

(a) *Employment Practices.* In performing its Work under this Agreement, the Contractor must not engage in unlawful employment practices, such as (1) failing or refusing to hire or discharging any individual, or otherwise discriminating against any individual with respect to compensation or the terms, conditions, or privileges of the individual's employment, because of the individual's race, color, religion, sex, age, handicap/disability or national origin; or (2) limiting, segregating or classifying the Contractor's employees or applicants for employment in any way that would deprive or tend to deprive any individual of employment opportunities or otherwise adversely affect the individual's status as an employee, because of the individual's race, color, religion, sex, age, handicap/disability or national origin.

(b) *Civil Rights.* Contractor must comply with, and the procedures the Contractor utilizes and the Work the Contractor provides under this Agreement must comply with the Civil Rights Act of 1964, 42 U.S.C. sec. 2000 *et seq.* (1981), as amended, and the Civil Rights Act of 1991, P.L. 102-166. Attention is called to: Exec. Order No. 11246, 30 Fed. Reg. 12,319 (1965), reprinted in 42 U.S.C. 2000(e) note, as amended by Exec. Order No. 11375, 32 Fed. Reg. 14,303 (1967) and by Exec. Order No. 12086, 43 Fed. Reg. 46,501 (1978); Age Discrimination Act, 42 U.S.C. §§ 6101-6106 (1981); Age Discrimination in Employment Act, 29 U.S.C. §§621-34; Rehabilitation Act of 1973, 29 U.S.C. §§ 793-794 (1981); Americans with Disabilities Act, 42 U.S.C. §12101 *et seq.*; 41 C.F.R. Part 60 *et seq.* (1990); and all other applicable Laws.

10.3 State Requirements.

(a) *Illinois Human Rights Act.* The Contractor must comply with, and the procedures the Contractor utilizes and the Work the Contractor provides under this Agreement must comply with the Illinois Human Rights Act, 775 ILCS 5/1-101 *et seq.* (1990), as amended and any rules and regulations promulgated in accordance with it, including the Equal Employment Opportunity Clause, 44 Ill. Admin. Code § 750 Appendix A. Furthermore, the Contractor must comply with the Public Works Employment Discrimination Act, 775 ILCS 10/0.01 *et seq.* (1990), as amended, and all other applicable Laws.

(b) *Veterans Preference.* The Contractor will comply with the provisions of 330 ILCS 55/0.01 *et seq.* which requires that a preference be given to veterans in the employment and

appointment to fill positions in the construction, addition, or alteration of all public works. In the employment of labor (except executive, administrative and supervisory positions) preference will be given to veterans of the Vietnam era and disabled veterans; however, this preference may be given only where the individuals are available and qualified to perform the Work to which the employment relates. The Contractor will insure that the provisions of this Section are inserted in all subcontracts entered into with any Subcontractors and labor organizations which furnish skilled, unskilled and craft union skilled labor, or which may provide any material, labor, or services in connection with this Agreement.

(c) *Steel Products.* The Contractor will comply with all applicable provisions of the Steel Products Procurement Act, 30 ILCS 565/1 *et seq.*, as it may be amended from time to time.

(d) *Employment of Illinois Laborers.* The Contractor will use only Illinois laborers in the performance of this Agreement, to the extent (i) required by the Employment of Illinois Laborers on Public Works Projects Act 30 ILCS 570/0.01 *et seq.*, as amended from time to time, and (ii) otherwise permitted by Law.

(e) *Prevailing Wage.* The Contractor will comply with 820 ILCS 130/0.01 *et seq.*, as it may be amended (the "**Prevailing Wage Act**"), so long as the Prevailing Wage Act is in effect, in order to ensure that such persons covered by the Prevailing Wage Act are paid the prevailing wage rate as ascertained by the Illinois Department of Labor. The specified rates to be paid to all laborers, workers, and mechanics for such craft or type of worker or mechanic as of the Commencement Date are included in Exhibit 10 attached hereto. If the Illinois Department of Labor revises such prevailing wage rates, the revised rates will apply to this Agreement, and the Contractor will not be entitled to an adjustment of the Contractor Fees therefor.

10.4 City Requirements.

(a) *Chicago Human Rights Ordinance.* The Contractor must comply with, and the procedures the Contractor utilizes and the Work the Contractor provides under this Agreement must comply with, the Chicago Human Rights Ordinance, ch. 2-160, Section 2-160-010 *et seq.* of the Municipal Code of Chicago (1990), as amended. Further, the Contractor must furnish and must cause each of its Subcontractor(s) to furnish such reports and information as requested by the Chicago Commission on Human Relations, and all other applicable City Ordinances and rules.

(b) *Chicago "Living Wage" Ordinance.* Section 2-92-610 of the Municipal Code of Chicago requires eligible contractors and their subcontractors to pay a living wage (as of the Commencement Date, \$7.60 per hour minimum base wage) to covered employees employed in the performance of this Agreement. The Contractor is an eligible contractor if, at any time during the performance of this Agreement, the Contractor has 25 or more full-time employees. If the Contractor is or becomes eligible, the Contractor and the Contractor's subcontractors must pay at least the base wage to covered employees. Covered employees are: security guards (but only if the Contractor and the Contractor's subcontractors employ in the aggregate 25 or more of them), and, in any number,

parking attendants, day laborers, home and health care workers, cashiers, elevator operators, custodial workers and clerical workers. Section 2-92-610 does not apply to not-for-profit corporations with federal 501(c)(3) tax exempt status. Also, if the Work is subject to payment of prevailing wages, and the prevailing wages are higher than the base wage, then prevailing wage rates apply and must be paid.

(c) *Inspector General.* It is the duty of the Contractor, all Subcontractors and all officers, directors, agents, partners and employees of the Contractor and Subcontractors to cooperate with the Inspector General in any investigation or hearing undertaken pursuant to Chapter 2-56 of the Municipal Code of Chicago. The Contractor understands and will abide by all provisions of Chapter 2-56 of the Municipal Code of Chicago.

(d) *MacBride Ordinance.*

- (i) The City, through the passage of the MacBride Principles Ordinance, seeks to promote fair and equal employment opportunities and labor practices for religious minorities in Northern Ireland and provide a better working environment for all citizens in Northern Ireland.
- (ii) In accordance with Section 2-92-580 of the Municipal Code of the City, if the primary contractor conducts any business operations in Northern Ireland, the contractor must make all reasonable and good faith efforts to conduct any business operations in Northern Ireland in accordance with the MacBride Principles for Northern Ireland as defined in Illinois Public Act 85-1390 (1988 Ill. Laws 3220).

(e) *Business Relationships with Elected Officials.*

- (i) Pursuant to Section 2-156-030(b) of the Municipal Code of the City, it is illegal for any elected official of the City, or any person acting at the direction of such official, to contact, either orally or in writing, any other City official or employee with respect to any matter involving any person with whom the elected official has a business relationship, or to participate in any discussion in any City Council committee hearing or in any City Council meeting or to vote on any matter involving the person with whom an elected official has a business relationship. **Violation of Section 2-156-030(b) by any elected official with respect to this Agreement is grounds for termination of this Agreement.**
- (ii) Section 2-156-080 defines a “**business relationship**” as any contractual or other private business dealing of an official, or his or her spouse, or of any entity in which an official or his or her spouse has a financial interest, with a person or entity which entitles an official to compensation or payment in the

amount of \$2,500 or more in a calendar year; provided, however, a financial interest shall not include: (A) any ownership through purchase at fair market value or inheritance of less than one percent of the share of a corporation, or any corporate subsidiary, parent or affiliate thereof, regardless of the value of or dividends on such shares, if such shares are registered on a securities exchange pursuant to the Securities Exchange Act of 1934, as amended; (B) the authorized compensation paid to an official or employee for his office or employment; (C) any economic benefit provided equally to all residents of the City; (D) a time or demand deposit in a financial institution; or (E) an endowment or insurance policy or annuity contract purchased from an insurance company. A "contractual or other private business dealing" shall not include any employment relationship of an official's spouse with an entity when such spouse has no discretion concerning or input relating to the relationship between that entity and the City.

(f) *Employment of City Residents.* The Contractor must comply with the Chicago Residency Ordinance, Section 2-92-330 of the Chicago Municipal Code, including the following provisions:

- (i) Except as otherwise prohibited by Law, the Contractor and all Subcontractors performing work on the site of the Project will comply with the minimum percentage of total worker hours performed by actual residents of the City of Chicago specified in Section 2-92-330 of the Municipal Code of Chicago (at least 50 percent of the total worker hours will be performed by actual residents of the City of Chicago). Provided, however, that in addition to complying with this percentage, the Contractor and all Subcontractors will make good faith efforts to utilize qualified residents of the City of Chicago in both unskilled and skilled labor positions.
- (ii) The Contractor may request a reduction or waiver of this minimum percentage level of Chicagoans as provided for in Section 2-92-330 in accordance with standards and procedures developed by the Chief Procurement Officer.
- (iii) "Actual residents of the City of Chicago" will mean persons domiciled within the City of Chicago. The domicile is an individual's one and only true, fixed and permanent home and principal establishment.
- (iv) The Contractor will provide for the maintenance of adequate employee residency records to ensure that actual Chicago residents are employed on the project. The Contractor and Subcontractors will maintain copies of personal documents supportive of every Chicago employee's actual record of residence.

- (v) Weekly certified payroll reports (U.S. Department of Labor Form WH-347 or equivalent) submitted to the commissioner of each supervising department, in triplicate, will identify clearly the actual residence of every employee on each submitted certified payroll. The first time that an employee's name appears on a payroll, the date the company hired the employee should be written in after the employee's name.
- (vi) Full access to the Contractor's employment records and the employment records of Subcontractors of the first tier will be granted to the Chief Procurement Officer, the commissioner of each supervising department, the Superintendent of the Chicago Police Department, the Inspector General, or any duly authorized representative thereof. The Contractor and Subcontractors of the first tier will maintain all relevant personnel data and records for a period of at least three years after final acceptance of the Work.
- (vii) At the direction of a supervising department, affidavits and other supporting documentation will be required of the Contractor to verify or clarify an employee's actual address when doubt or lack of clarity has arisen.
- (viii) Good faith efforts on the part of the Contractor to provide utilization of actual Chicago residents (but not sufficient for the granting of a waiver request as provided for in the standards and procedures developed by the Chief Procurement Officer) will not suffice to replace the actual, verified achievement of the requirements of this Section concerning the worker hours performed by actual Chicago residents.
- (ix) When the Work is complete, in the event that the City has determined that the Contractor failed to ensure the fulfillment of the requirement of this section concerning the worker hours performed by actual Chicago residents or failed to report in the manner as indicated above, the City will thereby be damaged in the failure to provide the benefit of demonstrable employment to Chicagoans to the degree stipulated in this section. Therefore, in such a case of non-compliance it is agreed that 1/20 of one percent, or 0.0005, of the value of this Agreement, as determined by the Chief Procurement Officer, will be surrendered by the Contractor to the City in payment for each percentage of shortfall toward the stipulated residency requirement. Failure to report the residency of employees entirely and correctly will result in the surrender of the entire liquidated damages as if no Chicago residents were employed. The willful falsification of statements in the certification of payroll data may subject the Contractor or Subcontractors or employee to prosecution.
- (x) Nothing herein provided will be construed to be a limitation upon the Notice of Requirements For Affirmative Action To Ensure Equal Employment

Opportunity, Executive Order 11246 and Standard Federal Equal Employment Opportunity, Executive Order 11246 or other affirmative action required for equal opportunity under the provisions of this contract. The Contractor will include this provision in all subcontracts with Subcontractors of the first tier.

(g) *Equal Employment.* Section 2-92-390 of the Municipal Code of Chicago is deemed applicable to this Agreement. The Contractor will complete all forms required by the City relating to Section 2-92-390.

10.5 Subcontractors.

(a) *Provisions of Subcontracts.* The Contractor must expressly include all provisions of this Article 10 in all agreements or subcontracts entered into with any Subcontractors of the first tier.

(b) *Assignment of Subcontracts.* Concurrent with the execution of any subcontract with a Subcontractor of the first tier, the Contract must assign such subcontract to the City. Such assignment must be automatically effective upon the Chief Procurement Officer's declaring the Contractor in default.

ARTICLE 11 SPECIAL CONDITIONS

11.1 Warranties and Representations. In connection with the execution and performance of this Agreement, the Contractor:

(a) warrants that the Contractor is appropriately licensed under all applicable Law to perform the Work required under this Agreement and will not perform Work for which a professional license is required by Law if the Contractor is not appropriately licensed;

(b) warrants it is financially solvent; it and each of its employees, agents and Subcontractors are competent to perform the Work required under this Agreement; and the Contractor is legally authorized to execute and perform or cause to be performed this Agreement under the terms and conditions stated in this Agreement;

(c) warrants that it will not knowingly use the services of any ineligible consultant or Subcontractor for any purpose in the performance of its Work under this Agreement;

(d) warrants that the Contractor and, to the best of its knowledge, its Subcontractors are not in default at the time this Agreement is signed, have not been considered by the Chief Procurement Officer within 5 years immediately preceding the Commencement Date, to have been in default on any contract awarded by the City;

(e) represents that it has carefully examined and analyzed the provisions and requirements of this Agreement; it understands the nature of the work required; from its own analysis it has satisfied itself as to the nature of all things needed for the performance of this Agreement; performance of this Agreement is feasible in accordance with all of its provisions and requirements, and the Contractor warrants it can and will perform, or cause to be performed, the Work in strict accordance with the provisions and requirements of this Agreement;

(f) represents that the Contractor and, to the best of its knowledge, its Subcontractors are not in violation of the provisions of Section 2-92-320 of Chapter 2-92 of the Municipal Code of Chicago, and in connection with it, and additionally in connection with the Illinois Criminal Code, 720 ILCS 5/33E as amended, and the Illinois Municipal Code, 65 ILCS 5/11-42.1-1; and

(g) acknowledges that any certification, affidavit or acknowledgment made under oath in connection with this Agreement is made under penalty of perjury and, if false, is also cause for termination pursuant to Article 12.

11.2 Ethics. In addition to the foregoing warranties and representations, the Contractor warrants:

(a) No officer, agent or employee of the City is employed by the Contractor or has a financial interest directly or indirectly in this Agreement or the compensation to be paid under this Agreement except as may be permitted in writing by the Board of Ethics established pursuant to the Municipal Code of Chicago (Chapter 2-156);

(b) No payment, gratuity or offer of employment will be made in connection with this Agreement by or on behalf of any Subcontractors to the Contractor or higher tier Subcontractors or anyone associated with them, as an inducement for the award of a subcontract or order; and

(c) The Contractor further acknowledges that any Agreement entered into, negotiated or performed in violation of any of the provisions of Chapter 2-156 is voidable as to the City.

11.3 Joint and Several Liability. If the Contractor; or its successors or assigns, if any, is comprised of more than one individual or other legal entity (or a combination of them), then under this Agreement, each and without limitation every obligation or undertaking in this Agreement to be fulfilled or performed by the Contractor is the joint and several obligation or undertaking of each such individual or other legal entity.

11.4 Business Documents. At the request of the City, the Contractor must provide copies of its latest articles of incorporation, by-laws and resolutions, or partnership or joint venture agreement, as applicable.

11.5 Prohibited Conflicts.

(a) *No Personal Interest.* No member of the governing body of the City or other unit of government and no other officer, employee or agent of the City or other unit of government who exercises any functions or responsibilities in connection with the Work to which this Agreement pertains is permitted to have any personal interest, direct or indirect, in this Agreement. No member of or delegate to the Congress of the United States or the Illinois General Assembly and no alderman of the City or City employee is allowed to be admitted to any share or part of this Agreement or to any financial benefit that arises from it.

(b) *No Conflict of Interest.*

(i) The Contractor covenants that it, and to the best of its knowledge, its Subcontractors if any (collectively, the "**Consulting Parties**"), presently have no direct or indirect interest and will not acquire any interest, direct or indirect, in any project or contract that would conflict in any manner or degree with the performance of its Work under this Agreement.

(ii) The Contractor further covenants that, in the performance of this Agreement, no person having any conflicting interest will be assigned to perform any Work or have access to any confidential information, as described in Section 3.10 of this Agreement. If the City, by the Commissioner in his reasonable judgment, determines any of the Contractor's work for others conflict with the Work the Contractor is to render for the City under this Agreement, the Contractor must terminate such other work immediately upon request of the City.

(c) *Disclosure.* Upon the request of the City, the Contractor must disclose to the City its past client list and the names of any clients with whom it has an ongoing relationship. The Contractor is not permitted to perform any Work for the City on applications or other documents submitted to the City by any of the Contractor's past or present clients. If the Contractor becomes aware of such a conflict, it must immediately stop work on the assignment causing the conflict and notify the City.

(d) *Consulting Parties.* Without limiting the foregoing, if the Consulting Parties assist the City in determining the advisability or feasibility of a project or in recommending, researching, preparing, drafting or issuing a request for proposals or bid specifications for a project, the Consulting Parties must not participate, directly or indirectly, as a prime, subcontractor or joint venturer in the Work while this Agreement is in effect or afterwards. The Consulting Parties may, however, assist the City in reviewing the proposals or bids for the project if none of the Consulting Parties have a relationship with the persons or entities that submitted the proposals or bids for that project.

(e) *Federal Lobbying Restrictions.* If any federal funds are to be used to compensate or reimburse the Contractor under this Agreement, the Contractor represents that it is and will remain

in compliance with federal restrictions on lobbying set forth in Section 319 of the Department of the Interior and Related Agencies Appropriations Act for Fiscal year 1990, 31 U.S.C. § 1352, and related rules and regulations set forth at 54 Fed. Reg. 52,309 ff. (1989), as amended. If federal funds are to be used, the Contractor must execute a Certification Regarding Lobbying, which will be attached as an exhibit and incorporated by reference as if fully set forth here.

11.6 No Liability of Public Officials. Contractor and any assignee or Subcontractor of the Contractor must not charge any official, employee or agent of the City personally with any liability or expenses of defense or hold any official, employee or agent of the City personally liable to them under any term or provision of this Agreement or because of the City's execution, attempted execution or any breach of this Agreement.

ARTICLE 12 EVENTS OF DEFAULT, REMEDIES, TERMINATION, SUSPENSION AND EXCUSABLE EVENTS

12.1 Events of Default Defined. Each of the following constitutes an event of default by the Contractor under this Agreement:

- (a) Any material misrepresentation, whether negligent or willful and whether in the inducement or in the performance, made by the Contractor to the City;
- (b) The Contractor admits in writing its inability or unwillingness to pay its debts as they become due;
- (c) The breach of any material representation or warranty made by the Contractor herein;
- (d) The Contractor's failure to perform any of its obligations under this Agreement including, without limitation, the following:
 - (i) One material failure or multiple non-material failures to perform the Work in accordance with the requirements of this Agreement;
 - (ii) Failure to pay the City amounts due in accordance with the terms of this Agreement;
 - (iii) Failure to perform the Work in accordance with the provisions of this Agreement or applicable Laws;
 - (iv) Failure to promptly correct within a reasonable time the Work that is defective;

- (v) Discontinuance of the Work for reasons within the Contractor's reasonable control;
- (vi) Failure of the Contractor or the Work to comply with a material term of this Agreement, including, but not limited to, the provisions concerning insurance, nondiscrimination and minority and women's business enterprises commitment;
- (vii) Failure to comply with the Installation Schedule, maintenance standards and schedule of availability set forth in Exhibits 1C, 1D and 7, respectively;
- (viii) Any change in ownership or control of the Contractor without the prior written approval of the Chief Procurement Officer, which approval the Chief Procurement Officer will not unreasonably withhold;
- (ix) Any attempt by Contractor to assign, convey or transfer this Agreement or any interest herein without the City's prior written consent;
- (x) The Contractor's default under any other agreement it may presently have or may enter into with the City during the life of this Agreement. The Contractor acknowledges and agrees that in the event of a default under this Agreement the City may also declare a default under any such other Agreements;
- (xi) Inability to perform the Work satisfactorily or pay the amounts due the City pursuant to this Agreement as a result of insolvency, filing for bankruptcy or assignment for the benefit of creditors; and
- (xii) The Contractor's repeated or continued violations of City ordinances unrelated to performance under the Agreement that in the opinion of the Chief Procurement Office indicate a willful or reckless disregard for City laws and regulations.

12.2 Remedies.

(a) *Events of Default and Maximum Time for Cure.* The occurrence of any event of default permits the City, at the City's sole option, to declare the Contractor in default of this Agreement. The Contractor will have an opportunity to cure an event of default within the cure period granted by the Chief Procurement Officer pursuant to Section 12.2(b) below. In no event will the Contractor be permitted more than 15 days to cure any monetary event of default or more than 60 days to cure any other event of default. The Chief Procurement Officer has sole discretion as to whether to declare the Contractor in default of this Agreement and neither that decision nor the factual basis for it is subject to review or challenge under this Agreement.

(b) *Notice of Default and Determination of Cure Period.* If the Chief Procurement Officer declares the Contractor in default of this Agreement, he will give the Contractor written notice of an event of default in the form of a cure notice (the “**Cure Notice**”), specifying that the Contractor must cure the event of default described in the notice within 15 days. Following issuance of a Cure Notice, the Chief Procurement Officer may grant the Contractor longer than 15 days, but not more than 60 days, to cure such event of default if, in his sole discretion, the following requirements are satisfied: (i) the event of default is a non-monetary default and cannot be cured within 15 days, (ii) the Contractor has (immediately upon receipt of the Cure Notice) diligently begun and is diligently and continuously proceeding to cure such default, and (iii) such default is reasonably susceptible to cure within a period of time longer than 15 days, but not more than 60 days. Upon the lapse of the cure period granted by the Chief Procurement Officer, if the Contractor has failed to effect a cure, the Chief Procurement Officer may give the Contractor a written default notice (“**Default Notice**”). If the Chief Procurement Officer gives a Default Notice, he will also indicate any present intent he may have to terminate this Agreement, and the decision to terminate (but not the decision not to terminate) is final and effective upon giving such a Default Notice. When a Default Notice with intent to terminate is given as provided in this Article 12, the Contractor must discontinue any Work, unless otherwise directed in the notice, and deliver all materials accumulated in the performance of this Agreement, whether completed or in the process, to the City. After or contemporaneously with the giving of a Default Notice, the City may invoke any or all of the following remedies:

- (i) The right to take over and complete the Work, or any part of it, at the Contractor’s expense and as agent for the Contractor, either directly or through others. If the City exercises such right, it shall bill the Contractor for the cost of the Work and all related expenses incurred by the City in completing the Work, and the Contractor must pay the City the total amount of each bill within 10 days of notice from the City;
- (ii) The right to terminate this Agreement as to any or all of the Work yet to be performed, effective at a time specified by the City;
- (iii) The right of specific performance, an injunction or any other appropriate equitable remedy;
- (iv) The right to money damages;
- (v) The right to consider the Contractor non-responsible with respect to future contracts to be awarded by the City;
- (vi) The right to:
 - (A) Require payment of all Contractor Fees and other amounts which would have been payable by the Contractor to the City through the end of the then-current term of this Agreement had the Agreement not been

terminated for default. In such event, the City shall use reasonable efforts to operate, or retain another contractor to operate, a street furniture program using the Street Furniture (in accordance with Section 12.2(b)(viii) below) and sell advertising for placement on the Street Furniture upon terms determined by the City in its sole discretion. If the City is able to sell, or retain a contractor to sell, advertising for placement on the Street Furniture and the City receives fees from such sale of advertising (and to the extent such fees exceed the sum of all reasonable costs incurred by the City in retaining a contractor, if applicable, and operating a street furniture program), the City shall deduct the amount of such fees from the Contractor Fees payable by the Contractor to the City through the end of the then-current term of this Agreement. In the event such fees (after deduction of all costs incurred by the City in retaining a contractor, if applicable, and operating a street furniture program) exceed the Contractor Fees payable by the Contractor to the City through the end of the then-current term of this Agreement, the City shall be entitled to retain all such fees received from the sale of advertising or the new contractor; or

- (B) Require payment from the Contractor, as damages for loss of the benefit of the City's bargain and not as a penalty, a sum equal to: (1) Contractor Fees due and payable to the City through the date of issuance of the Default Notice, (2) the greater of \$5,000,000 and the sum of all Contractor Fees to become due and payable to the City over the 12-month period subsequent to issuance of the Default Notice, (3) the amount of any damages suffered by the City other than the loss of payment of the Contractor Fees by the Contractor, and (4) any other amount as may be due to the City, as determined by a court of competent jurisdiction. In such event, the City shall be under no obligation to sell advertising for placement on the Street Furniture and the City may, in its sole discretion, operate a street furniture program using the Street Furniture (in accordance with Section (12.2(b)(viii) below);
- (vii) The right to take over and complete the Work, or any part thereof, either directly or through others. The City may use the Contractor's or Subcontractor's materials and equipment to complete the Work as indicated herein. Upon the City's notification to the Contractor that it intends to invoke this remedy, any and all rights the Contractor may have in or under its subcontracts will be deemed assigned to the City. The sole obligation accepted by the City under such subcontracts will be to pay for Work satisfactorily performed after the date of the assignment. In the event a

conditional assignment has not been executed, the Contractor must execute, or cause to be executed, any assignment, agreement, or other document which may be necessary, in the sole opinion of the City's legal counsel, to evidence or effect compliance with this provision. The Contractor must promptly deliver such documents upon the City's request therefor. In the case of any subcontract so assigned and accepted by the City, the Contractor must remain liable to the Subcontractors for any payment already invoiced to and paid by the City, and for any claim, suit, or cause of action based on or the result of any error, omission, negligence, fraud, willful or intentionally tortuous conduct, or any other act or omission, or breach of contract by the Contractor, its officers, employees, agents, and other Subcontractors, arising prior to the date of assignment to the City, when such claim, suit, or cause of action has not been discharged, disposed of, or otherwise resolved as of that date. The Contractor must notify its Subcontractors of these requirements; and

- (viii) The right to operate a street furniture program using the Street Furniture, pursuant to a license and all other necessary grants of rights from the Contractor until the end of the then-current term of this Agreement (so long as the City pays to the Contractor at the end of each remaining year (or fraction thereof) in the then-current term an amount equal to the amount of the capital depreciation of the Street Furniture in such year (or fraction thereof), subject to appropriation by the City and all necessary authorizations).

(c) If the Chief Procurement Officer considers it to be in the City's best interests, he may elect not to declare a default or terminate this Agreement. The parties acknowledge that this provision is solely for the benefit of the City and that if the City permits the Contractor to continue to provide the Work despite one or more events of default, the Contractor is in no way relieved of any of its responsibilities, duties or obligations under this Agreement, nor does the City waive or relinquish any of its rights.

(d) The remedies provided to the City under the terms of this Agreement are not intended to be exclusive of any other remedies provided, but each and every such remedy is cumulative and is in addition to any other remedies, existing now or later, at law, in equity and/or by statute. No delay or omission by the City in exercising any right or power accruing upon any event of default impairs any such right or power, nor is it a waiver of any event of default nor acquiescence in it, and every such right and power may be exercised from time to time and as often as the City considers expedient.

(e) The Contractor waives all claims against the City, the CTA and the CPD for any consequential, special, incidental, exemplary, indirect or punitive damages or attorneys' fees, regardless of whether any such claim arises out of breach of contract or warranty, tort, product, liability, indemnity, contribution, strict liability or other legal theory. The Contractor covenants and

agrees that it will obtain a written waiver of claims against the City identical to the waiver set forth in the preceding sentence, from each Subcontractor performing any portion of the Work.

12.3 Suspension.

(a) *City's Right to Suspend Work.* The City may at any time request that the Contractor suspend the installation of Street Furniture by giving 15 days' prior written notice to the Contractor or upon informal oral, or even no notice, in the event of emergency. The City shall not be responsible for any costs incurred in connection with such suspension. The Contractor must promptly resume its installation of Street Furniture under the same terms and conditions as stated in this Agreement upon written notice by the Chief Procurement Officer and such equitable extension of time as may be mutually agreed upon by the Chief Procurement Officer and the Contractor when necessary for continuation or completion of the Work.

(b) *Duration of Suspension.* No suspension of this Agreement is permitted in the aggregate to exceed a period of ten days within any one year of this Agreement.

12.4 Payment of Excess Costs. In connection with performance under this Agreement, the Contractor must pay the City, within five days of the City's providing written notice to the Contractor, an amount equal to any excess costs incurred by the City in the event of termination of this Agreement for default or otherwise resulting from the Contractor's failure to perform in accordance with the provisions of this Agreement or if the City exercises any of the remedies available to it under Section 12.2. This right is in addition to and not a limitation of any other remedies available to the City pursuant to this Agreement, at law or in equity.

12.5 Excusable Events and Schedule and Fee Adjustments. The Contractor may be granted an extension in the Installation Schedule or other time schedules relating to performance of the Work set forth in this Agreement or an abatement in the Contractor Fees in relation to an Excusable Event only as described in this Section 12.5.

(a) *Adjustments in Schedule for Performance Relating to Excusable Event.* The Contractor will be granted an extension in the Installation Schedule, maintenance schedules or other time schedules relating to performance of the Work set forth in this Agreement, including the Installation Deadline (excluding, however, time for payment of Contractor Fees as described in Article 6) only under the following circumstances: (a) a delay occurs in the progress of the Work as a result of one of the Excusable Events identified below in Sections 12.5(f) (i) or (iii), and (b) the Contractor has complied with the terms and conditions of the following subsections:

- (i) The Contractor, as soon as reasonably possible and in no event later than five days after the date upon which the Contractor has knowledge of the Excusable Event, notifies the City in writing of the occurrence of the event and the approximate number of hours or days the Contractor expects to be delayed as a result of such event; and the Contractor makes a written request for an

extension of time to the City within five days after the cessation of the Excusable Event specifying the number of hours or days the Contractor believes that its activities will in fact be delayed as a result of the event. The Contractor will not be entitled to any extension in schedule for any period of time prior to the date on which the Contractor gives notice to the City of the relevant Excusable Event.

- (ii) The Contractor can demonstrate, to the reasonable satisfaction of the City, that the activity claimed to have been delayed was in fact delayed by the Excusable Event, and that the delay in such activity will result in a delay in the progress of the Work.
- (iii) The initial notice provided by the Contractor under subsection (i) above must describe the efforts of the Contractor that have been (or are going to be) undertaken by the Contractor to overcome or remove the Excusable Event and to minimize the potential adverse effect on the time for performance of the Work resulting from such Excusable Event.

(b) *Adjustments in Schedule for Performance Relating to City Delay.* If the City does not select a site for a piece of Street Furniture (excluding CIPs) by the applicable Site Selection Date, the Contractor will be entitled to an extension in the Installation Schedule for such piece of Street Furniture of one day for every one day between the Site Selection Date and the date on which the City selects the relevant site. If the City does not issue an Installation Permit for a piece of Street Furniture by the applicable Permit Issuance Date, the Contractor will be entitled to an extension in the Installation Schedule and the Installation Deadline for such piece of Street Furniture of one day for every day between the Permit Issuance Date and the date on which the City issues the relevant Installation Permit.

(c) *Adjustments in Contractor Fees Relating to Excusable Event.* The Contractor will be granted an abatement in the Contractor Fees payable to the City in a particular calendar year, as set forth in the Abatement Schedule and formula included in Exhibit 2, under the following circumstances: (a) in such calendar year, a demonstrable Economic Loss to the Contractor results from the occurrence of an Excusable Event identified below in Section 12.5(f)(ii) or (iv); and (b) the Contractor has complied with the terms and conditions of the following subsections:

- (i) The Contractor, within five days of the date upon which the Contractor has knowledge of the Excusable Event, notifies the City in writing of the occurrence of the event and the Economic Loss the Contractor expects to suffer as a result of such event; and the Contractor makes a written request for an abatement of Contractor Fees to the City within five days after the cessation of the Excusable Event specifying the Economic Loss suffered by the Contractor as a result of such event. The Contractor must provide the Project Manager with sufficient documentation and other evidence of Economic Loss

to enable the Project Manager, in her sole discretion, to determine the existence and extent of Economic Loss suffered by the Contractor as a result of an Excusable Event. The Contractor will not be entitled to any abatement in the Contractor Fees for any period of time prior to the date on which the Contractor gives notice to the City of the relevant Excusable Event.

- (ii) The Contractor can demonstrate, to the reasonable satisfaction of the City, that the Economic Loss claimed to have been suffered was in fact caused by the Excusable Event.
- (iii) The initial notice provided by the Contractor under subsection (i) above shall describe the efforts of the Contractor that have been (or are going to be) undertaken by the Contractor to overcome or remove the Excusable Event and to minimize the Economic Loss to the Contractor resulting from such Excusable Event.

(d) *Adjustments in Contractor Fees Relating to City Delay.* If the City does not issue an Installation Permit for a piece of Street Furniture bearing an Ad Panel by the applicable Permit Issuance Date and, as a result, the Contractor is not able to install such piece of Street Furniture by the last day of the quarter in which such piece is to be installed pursuant to Exhibit 1C, the Contractor will be entitled to an abatement in the Contractor Fees for such piece of Street Furniture beginning on the Permit Issuance Date and ending on the date the City issues the relevant Installation Permit. Any abatements pursuant to this Section 12.5(d) shall be calculated in accordance with the Abatement Schedule and formula included in Exhibit 2, on the basis of the type of Street Furniture and the location at which it was to be installed.

(e) *Compliance is Prerequisite to Adjustment Relating to Excusable Event.* Compliance with this Section 12.5 is a condition precedent to receipt of an extension in the Contractor's time for performance of the Work (including an adjustment to the Installation Deadline or maintenance schedules) or an abatement of Contractor Fees due to an Excusable Event. In the event of a failure to comply with this Section 12.5, the Contractor will not be entitled to an extension of time for performance of the Work (including an adjustment to the Installation Deadline) or an abatement of Contractor Fees due to an Excusable Event. In confirmation and furtherance of the foregoing, the Contractor must comply with all maintenance standards and maintenance schedules for the Street Furniture during and after the occurrence of an Excusable Event, except to the extent otherwise specifically provided in Section 12.5(a). Upon satisfaction by the Contractor of the terms and conditions in Section 12.5(a) or (b), if the Contractor is seeking a schedule adjustment, the City and the Contractor will use good faith efforts to agree on the extent to which the Work has been delayed on account of an Excusable Event as provided above. Upon satisfaction by the Contractor of the terms and conditions in Section 12.5(c) or (d), if the Contractor is seeking an abatement of Contractor Fees, the City and the Contractor will determine the amount of the abatement of Contractor Fees by reference to the Abatement Schedule included in Exhibit 2 (to be adjusted in proportion to the actual impact of the Excusable Event on visibility or existence of Ad Panels; provided, however, that the

Contractor will not under any circumstances be entitled to a Contractor Fees' abatement in excess of that specified on the Abatement Schedule). The City shall make the final determination as to the length of the extension or the amount of the abatement in the Contractor Fees to be granted to the Contractor, if any, and such determination must be confirmed in writing signed by both parties. If the Contractor does not agree with such determination, it may dispute the City's decision in accordance with Article 7.

(f) *Excusable Events*. "**Excusable Event**" shall mean any of the following acts, events, conditions or occurrences to the extent that the same are beyond the Contractor's reasonable control, are not caused by the Contractor or its Subcontractors, could not have been either foreseen or avoided by the exercise of due diligence and which has an adverse effect on the Contractor's ability to perform its obligations hereunder or, with respect to events described in Section 12.5(f)(ii) below, which has an adverse effect on visibility or existence of Ad Panels:

- (i) Acts of God, fires, explosions, floods, acts of national or international terrorism (as reasonably determined by the City), earthquakes, tornadoes, epidemics, civil disturbances, war, riots, sabotage or strikes/lockouts/labor disputes (but only to the extent not targeted at the Contractor or Subcontractors);
- (ii) Acts of God, fires, explosions, floods, acts of national or international terrorism (as reasonably determined by the City), earthquakes, hurricanes, tornadoes, epidemics, civil disturbances, war, riots, sabotage strikes/lockouts/labor disputes (but only to the extent not targeted at the Contractor or Subcontractors), to the extent any such event prevents the public from viewing Ad Panels on Street Furniture for more than 30 days or prevents the Contractor from placing and maintaining Ad Panels on Street Furniture on which the Contractor has been authorized to place advertising pursuant to this Agreement for more than 30 days;
- (iii) the occurrence of a Change in Law; or
- (iv) the occurrence of a Change in Law (excluding Changes in Law resulting from orders, decisions, recommendations or rulings of judges, courts, arbitrators or other judicial authorities) only to the extent such a Change in Law increases the Contractor's actual cost of performing the Work, without regard to the Contractor's ability or inability to sell advertising for placement on Ad Panels. This Section 12.5(f)(iv) does not limit or alter the provisions of Section 4.7(e).

None of the foregoing events shall be deemed an Excusable Event to the extent that performance of the Work would have been suspended, delayed or interrupted by any other cause, including the fault or negligence of the Contractor, the Subcontractors or any other person for whom they may be liable.

(g) *Rights Limited.* The rights and remedies set forth in this Section 12.5 shall be the Contractor's sole and exclusive rights and remedies in the event of an occurrence of an Excusable Event or the failure of the City to select a site for a piece of Street Furniture by the applicable Site Selection Date or issue an Installation Permit by the applicable Permit Issuance Date or CIP Permit Date, as applicable. The Contractor hereby waives all other rights and remedies at law and/or in equity that it might otherwise have against the City on account of an Excusable Event or the failure of the City to select a site for a piece of Street Furniture by the applicable Site Selection Date or issue an Installation Permit by the applicable Permit Issuance Date or CIP Permit Date, as applicable.

ARTICLE 13 MISCELLANEOUS

13.1 Entire Agreement. This Agreement, and the exhibits attached to it and incorporated in it, constitute the entire agreement between the parties, and no other warranties, inducements, considerations, promises or interpretations are implied or impressed upon this Agreement that are not expressly addressed in this Agreement. This Agreement supersedes all prior or contemporaneous communications, representations or agreements, whether oral or written, relating to the Work and the Agreement, including, without limitation, the Initial Multiple Newsrack Program Agreement.

13.2 No Collateral Agreements. The Contractor acknowledges that, except only for those representations, statements or promises expressly contained in this Agreement and any exhibits attached to it and incorporated by reference in it, no representation, statement or promise, oral or in writing, of any kind whatsoever, by the City, its officials, agents or employees, has induced the Contractor to enter into this Agreement or has been relied upon by the Contractor, including any with reference to: (i) the meaning, correctness, suitability or completeness of any provisions or requirements of this Agreement; (ii) the nature of the Work to be performed; (iii) the nature, quantity, quality or volume of any materials, equipment, labor and other facilities needed for the performance of this Agreement; (iv) the general conditions which may in any way affect this Agreement or its performance; (v) the compensation provisions of this Agreement; or (vi) any other matters, whether similar to or different from those referred to in (i) through (vi) immediately above, affecting or having any connection with this Agreement, its negotiation, any discussions of its performance or those employed or connected or concerned with it.

13.3 No Omissions. The Contractor acknowledges that the Contractor was given ample opportunity and time and was requested by the City to review thoroughly all documents forming this Agreement before signing this Agreement in order that it might request inclusion in this Agreement of any statement, representation, promise or provision that it desired or on that it wished to place reliance. The Contractor did so review those documents, and either every such statement, representation, promise or provision has been included in this Agreement or else, if omitted, the Contractor relinquishes the benefit of any such omitted statement, representation, promise or provision and is willing to perform this Agreement in its entirety without claiming reliance on it or making any other claim on account of its omission.

13.4 Counterparts. This Agreement is comprised of several identical counterparts, each to be fully signed by the parties and each to be considered an original having identical legal effect.

13.5 Amendments. No changes, amendments, modifications or discharge of this Agreement, or any part of it are valid unless in writing and signed by the Commissioner of the CPD and the Chief Procurement Officer of the City or their respective successors and assigns, and approved as to form and legality by the Corporation Counsel, and signed by the Contractor (except to the extent this Agreement provides that it may be amended without an amendment signed by the Contractor).

13.6 Approval. Whenever in this Agreement the Contractor is required to obtain prior written approval, the effect of any approval that may be granted pursuant to the Contractor's request is prospective only from the later of the date approval was requested or the date on which the action for which the approval was sought is to begin. In no event is approval permitted to apply retroactively to a date before the approval was requested.

13.7 Governing Law and Jurisdiction. This Agreement is governed as to performance and interpretation in accordance with the Laws of the State of Illinois, without regard to conflicts of law principles. The Contractor irrevocably submits itself to the original jurisdiction of those courts located within the County of Cook, State of Illinois, with regard to any controversy arising out of, relating to, or in any way concerning the execution or performance of this Agreement. Service of process on the Contractor may be made, at the option of the City, either by registered or certified mail addressed to the applicable office as provided for in this Agreement, by registered or certified mail addressed to the office actually maintained by the Contractor, or by personal delivery on any officer, director, or managing or general agent of the Contractor. If any action is brought by the Contractor against the City concerning this Agreement, the action must be brought only in those courts located within the County of Cook, State of Illinois.

13.8 Severability. If any provision of this Agreement is held to be or is in fact invalid, illegal, inoperative or unenforceable as applied in any particular case in any jurisdiction or in all cases because it conflicts with any other provision or provisions of this Agreement or of any Law or public policy, or for any other reason, those circumstances do not have the effect of rendering the provision in question invalid, illegal, inoperative or unenforceable in any other case or circumstances, or of rendering any other provision or provisions in this Agreement invalid, illegal, inoperative or unenforceable to any extent whatsoever. The invalidity, illegality, inoperativeness or unenforceability of any one or more phrases, sentences, clauses or sections in this Agreement does not affect the remaining portions of this Agreement or any part of it, except to the extent an essential element of this Agreement is held to be or is in fact invalid, illegal, inoperative or unenforceable. The Contractor acknowledges and agrees that the Contractor's sole and exclusive remedy for a Change in Law or other Excusable Event is as provided in Article 12.5 and Section 4.7(e) of this Agreement

13.9 Assigns. All of the terms and conditions of this Agreement are binding upon and inure to the benefit of the parties and their respective legal representatives, permitted successors and assigns.

13.10 Cooperation. The Contractor must at all times cooperate fully with the City and act in the City's best interests. If this Agreement is terminated for any reason, or if it is to expire on its own terms, the Contractor must make every effort to assure an orderly transition to another provider of the Work, if any; orderly demobilization of its own operations in connection with the Work; uninterrupted provision of Work during any transition period and must otherwise comply with the reasonable requests and requirements of the Department in connection with the termination or expiration.

13.11 Waiver. Nothing in this Agreement authorizes the waiver of a requirement or condition contrary to Law or that would result in or promote the violation of any Law. Whenever under this Agreement the City by a proper authority waives the Contractor's performance in any respect or waives a requirement or condition to either the City's or the Contractor's performance, the waiver so granted, whether express or implied, only applies to the particular instance and is not a waiver forever or for subsequent instances of the performance, requirement or condition. No such waiver is a modification of this Agreement regardless of the number of times the City may have waived the performance, requirement or condition. Such waivers must be provided to the Contractor in writing.

13.12 Independent Contractor Status.

(a) This Agreement is not intended to and will not constitute, create, give rise to, or otherwise recognize a joint venture, partnership, corporation or other formal business association or organization of any kind between the Contractor and the City. The rights and the obligations of the parties are only those expressly set forth in this Agreement. The Contractor must perform under this Agreement as an independent contractor and not as a representative, employee, agent, or partner of the City.

(b) Nothing provided for under this Agreement constitutes or implies an employer-employee relationship between the City and the Contractor (or its employees, Key Personnel and Subcontractors) such that:

- (i) The City will not be liable under or by reason of this Agreement for the payment of any compensation award or damages in connection with the Contractor performing the Work required under this Agreement.
- (ii) Contractor is not entitled to membership in the City of Chicago Pension Fund, Group Medical Insurance Program, Group Dental Program, Group Vision Care, Group Life Insurance Program, Deferred Income Program, vacation, sick

leave, extended sick leave, or any other benefits ordinarily provided to individuals employed and paid through the regular payrolls of the City.

- (iii) The City is not required to deduct or withhold any taxes, FICA or other deductions from any compensation provided to the Contractor.

13.13 Notices. Notices provided for in this Agreement, unless expressly provided for otherwise in this Agreement, must be given in writing and may be delivered personally or by placing in the United States mail, first class and certified, return receipt requested, with postage prepaid and addressed as follows:

If to the City: Department of Planning and Development
Room 1000, City Hall
121 North LaSalle Street
Chicago, Illinois 60602
Attention: Commissioner

and Chicago Department of Transportation
30 North LaSalle Street
Room 1100
Chicago, Illinois 60602
Attention: Commissioner

and Department of Procurement Services
Room 403, City Hall
121 North LaSalle Street
Chicago, Illinois 60602
Attention: Chief Procurement Officer

and Office of the Mayor of the City of Chicago
Room 406, City Hall
121 North LaSalle Street
Chicago, Illinois 60602
Attention: Street Furniture Project Manager

With a copy to: Department of Law
Room 600, City Hall
121 North LaSalle Street
Chicago, Illinois 60602
Attention: Corporation Counsel

If to the Contractor: JCDecaux Chicago, LLC
221 North LaSalle Street, Suite 1137
Chicago, Illinois 60601
Attention: Nicolas Clochard-Bossuet

With a copy to: Greenberg, Traurig, LLP
200 Park Avenue
New York, New York 10166
Attention: Edward C. Wallace

Changes in these addresses must be in writing and delivered in accordance with the provisions of this Section 13.13. Notices delivered by mail are considered received three days after mailing in accordance with this Section 13.13. Notices delivered personally are considered effective upon receipt. Refusal to accept delivery has the same effect as receipt.

13.14 Rights Cumulative. The rights and remedies available to the City as set forth in this Agreement are cumulative with and in addition to, and not in limitation of, any other rights or remedies available to the City at law and/or in equity, and in addition, any specific right or remedy conferred upon or reserved to the City in any provision of this Agreement shall not preclude the concurrent or consecutive exercise of a right or remedy provided for in any other provision hereof.

13.15 Authority. Execution of this Agreement by the Contractor is authorized by a resolution of its Board of Directors, if a corporation, or similar governing document, and the signature(s) of each person signing on behalf of the Contractor have been made with complete and full authority to commit the Contractor to all terms and conditions of this Agreement, including each and every representation, certification and warranty contained in it, including the representations, certifications and warranties collectively incorporated by reference in it.

[Signature page follows.]

SIGNED at Chicago, Illinois:

CITY OF CHICAGO

By: [Signature]
Chief Procurement Officer

Approved as to form and legality:

[Signature]
Special Assistant Corporation Counsel
Roger J. Kiley, Jr.
Joanna K. Horsnail

[Signature]
Corporation Counsel

JCDECAUX CHICAGO, LLC

By: [Signature]
Its: PRESIDENT

Attest: [Signature]

Subscribed and sworn to before me this 28th
day of June, 2002.

[Signature]
Notary Public

My Commission expires: 7-6-2005



EXHIBIT 1A

Description of Street Furniture, Including Specifications

[attached]

JCDecaux

BUS STOP SHELTER

1. GENERAL INFORMATION

The Bus Stop Shelter is designed to protect the public from weather while waiting for buses. It may be equipped with a double-sided, internally illuminated advertising panel, as well as different amenities to serve the public. Some of these amenities include ceiling lights, bench, and bus route maps. The shelter is made with high quality materials that are designed to stand up to a variety of climates. Each shelter is designed in close coordination with the architectural firm Robert A.M. Stern LLP.

2. TECHNICAL DESCRIPTION

A. FOUNDATION:

Most of the Bus Stop Shelters will be bolted directly onto existing sidewalks or foundations. In some instances new concrete pads will be poured to support the shelter. Since we are using a bolting method, portions of the shelter can be replaced in the event of damage to the unit. Chemical anchors will be used when bolting the unit to concrete. The concrete pads will have a minimum strength of 3000 PSI.

B. BUS STOP SHELTER FEATURES

The standard shelter is comprised of a metal curved roof with cast ribs underneath for support. Six tubular columns with cast accents support the roof. The back and right side of the shelter are tempered architectural glass panels. Depending on the location, one side of the shelter will hold a double-sided advertising panel. All glass panels have markings to enhance the presence of the Bus Stop Shelter for those who are visually impaired. The glass panels are held in place by cast brackets that are mounted to the columns. All styles of the Bus Stop Shelter will be ADA compliant. The Bus Stop Shelter meets the City's wind exertion requirements. The minimum static load for the shelter will be 30lbs/ft². The horizontal lift will be 20lbs/ft², and the vertical lift will be 40lbs/ft². Each Bus Stop Shelter is equipped with a metal bench that has a wood or equivalent seat surface.

C. ELECTRICITY

Fluorescent lamps will be used to light the advertising panel. As required, ceiling lighting and clock backlighting may also be incorporated. All electrical connections will be made according to the electrical code specifications required by the City of Chicago. Safety features such as GFCI circuit breakers will be used for all light box and control box connections.

D. MATERIALS

Aluminum: Extrusion will be used for portions of the columns, roof, diffuser, frame, and doors. Column accents and roof supports will be cast in various shapes and sizes.

Steel: Prepainted sheet stock will be incorporated into the underside of the roof.

Paint: Baked on powder coat paint will be used on all external components. The roof, columns, and lightbox will be painted black. The accents for the columns and bus stop sign will be painted silver.

E. DIMENSIONS

The approximate dimensions for a standard 3 section Bus Stop Shelter are:

Length: 14 feet
Width: 5 -1/2 feet
Height: 9 feet

The approximate dimensions for a 2 section Bus Stop Shelter are:

Length: 9 -1/2 feet
Width: 5 -1/2 feet
Height: 9 feet

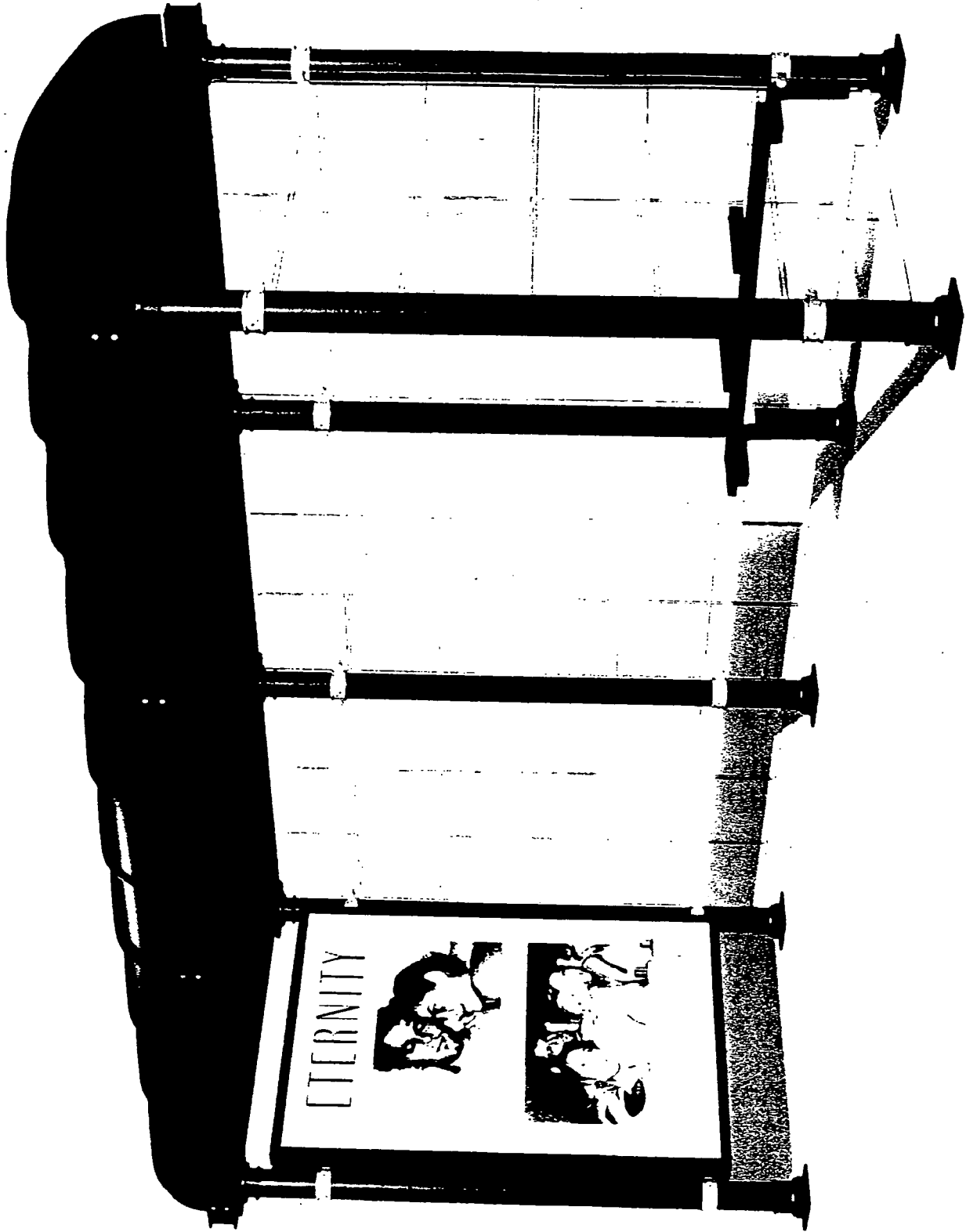

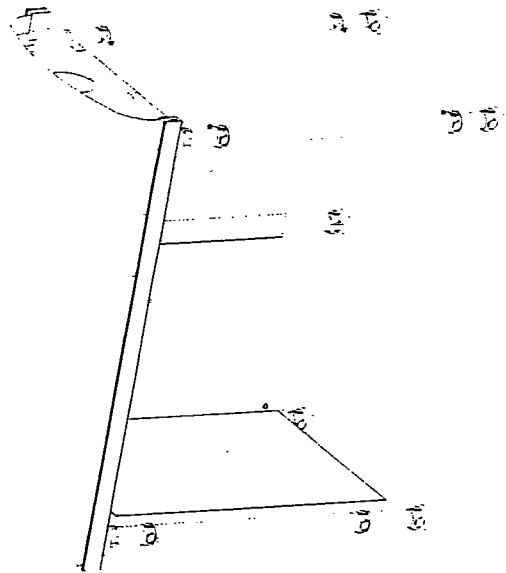
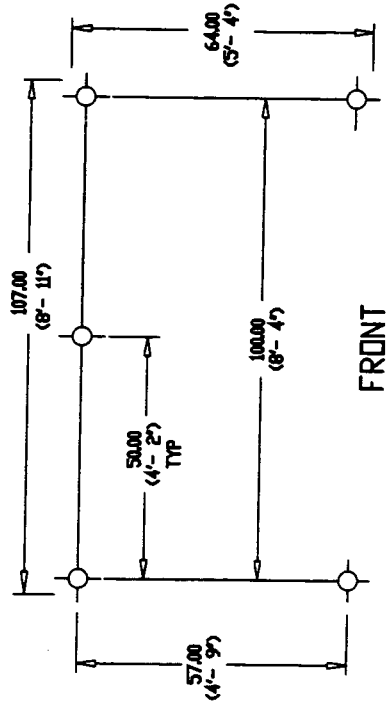
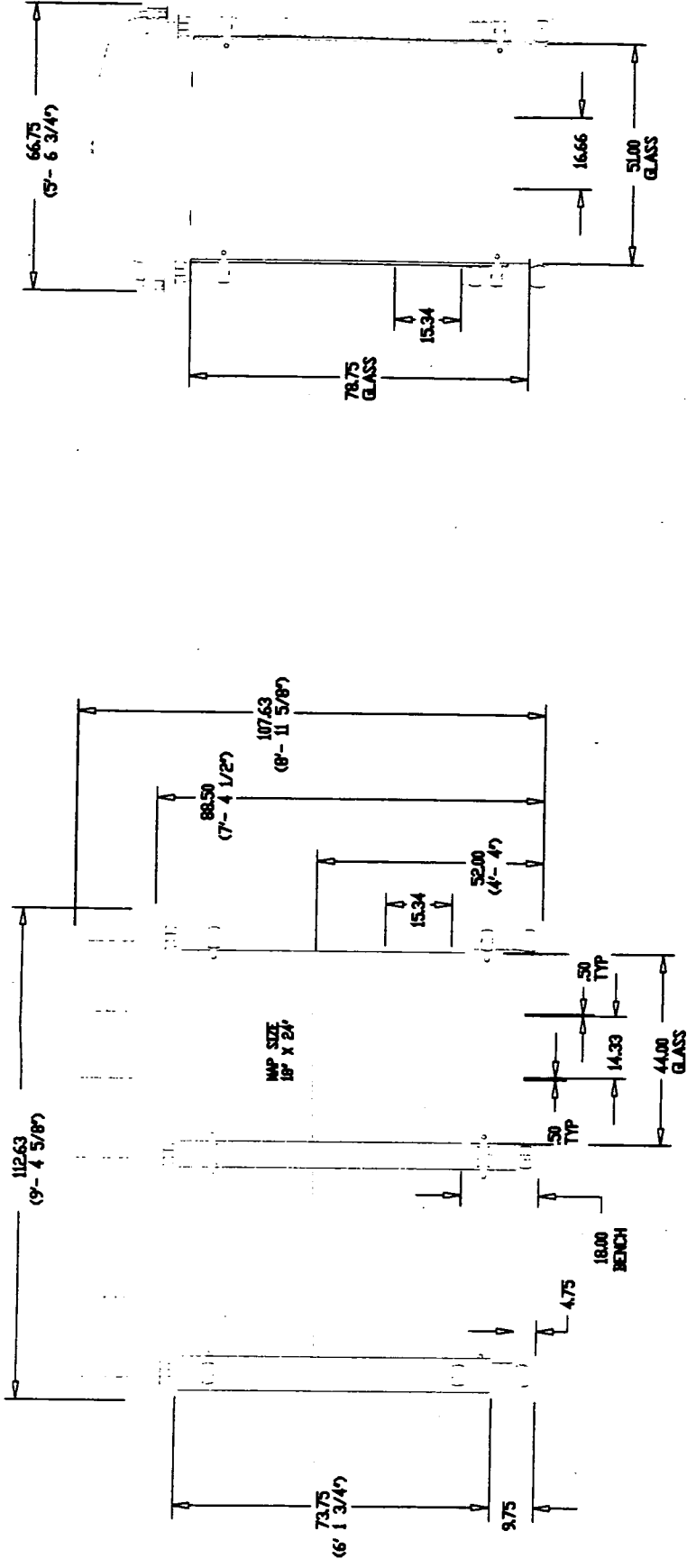

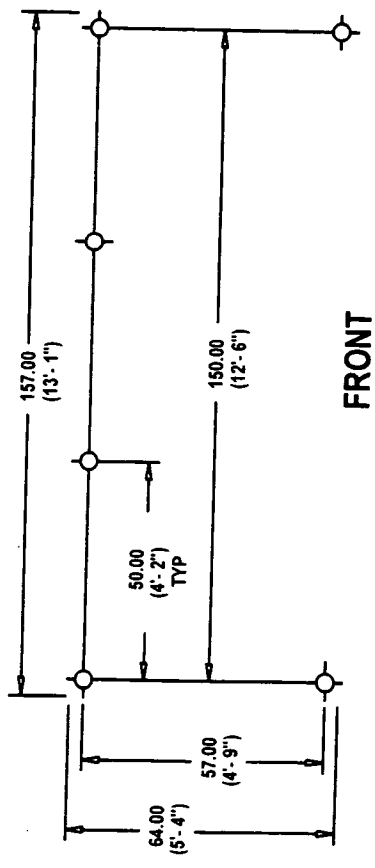
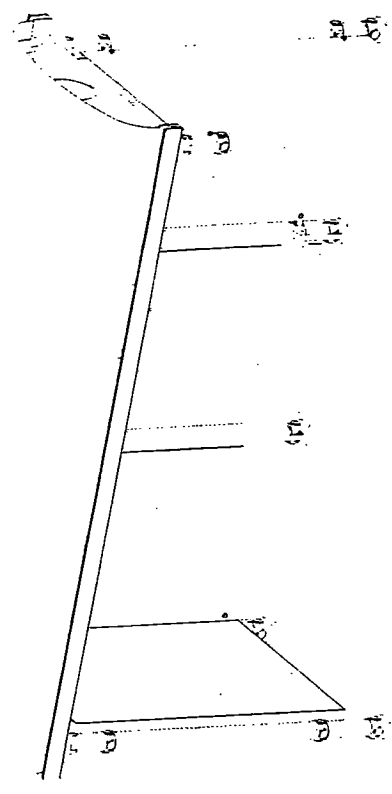
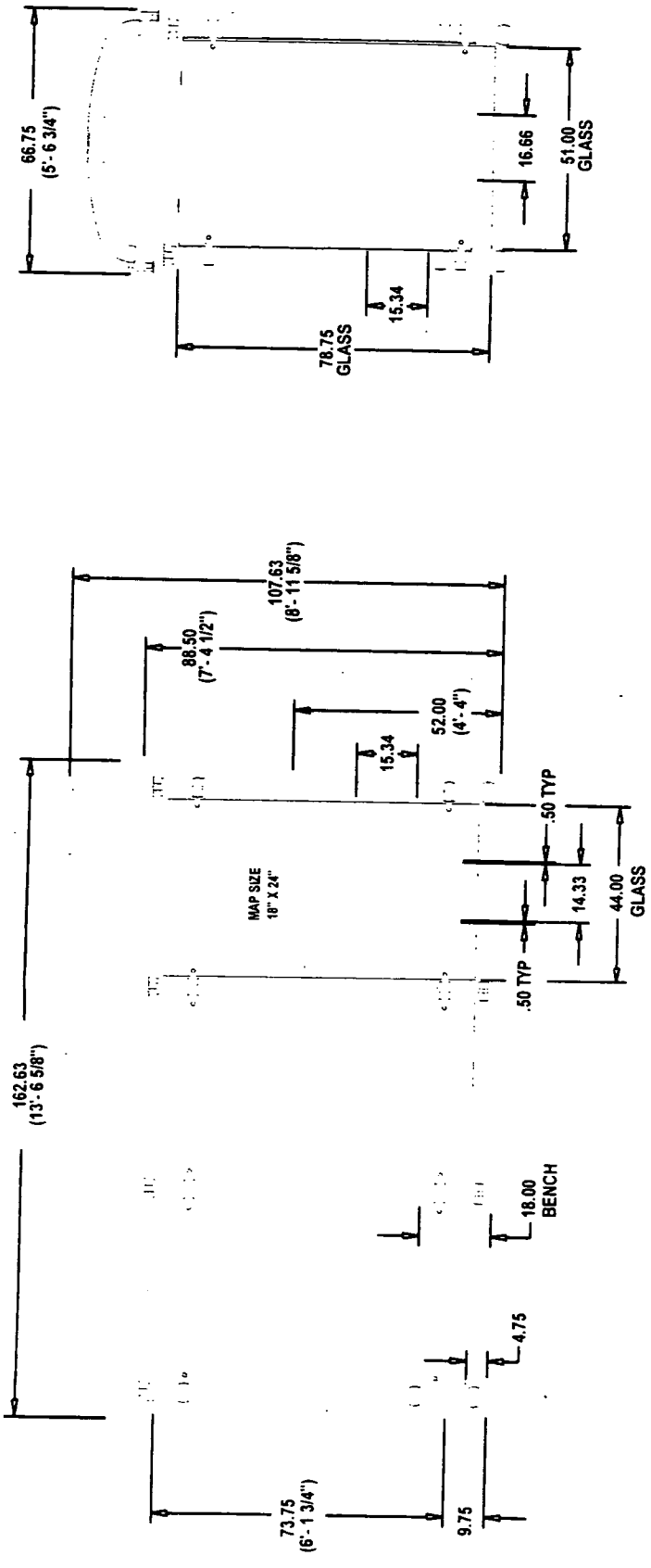

FRONT

6' 3/4"
6' 3/4"



CITY INFORMATION PANEL

1. GENERAL INFORMATION

This CIP is a freestanding structure that has a double-sided back-lit light box: one side will be used to post City Messages, and the other side will be used for advertising. The top of the CIP may incorporate a City of Chicago emblem and may integrate a top-sign displaying the type of City Message displayed on the unit. The design of the unit is from the HERITAGE line developed by JCDecaux.

2. TECHNICAL DESCRIPTION

A. FOUNDATION:

In most cases chemical anchors will be used to bolt the CIP directly onto sidewalks or concrete foundations. When new foundations are required, they will be made of concrete with a minimum strength of 3000 PSI.

B. CIP FEATURES

The exterior components of the CIP are comprised of metal and glass. The unit will have some silver accents on the top, base, and column sections. Glass panels will cover the information/advertising faces.

C. ELECTRICITY

GFCI circuit breakers will be used for the lightbox and control box connections. All electrical connections will be made according to the City of Chicago electrical code.

JCDecaux

D. MATERIALS

Aluminum: Extrusions and castings will be used for both internal and external components.

Steel: Steel sheet metal and machined components will be part of the top and the lightbox. All mounting hardware will be stainless steel to prevent corrosion.

Paint: Baked on powder coat paint will be used on all external components. External surfaces will be painted black. The only exception will be miscellaneous silver accents.

Glass: Protective tempered glass will be used to cover the lighted panels.

E. DIMENSIONS

The approximate closed base dimensions for a CIP are:

Length:	5-1/2	feet
Width:	10	inches
Height:	9	feet

City of Chicago

CHICAGO PUBLIC LIBRARY



At The Field Museum

TYRANNOSAURUS



READS

At The Chicago Public Library

SUMMER READING PROGRAM 2000

CO-SPONSORED BY THE FIELD MUSEUM

June 12th - August 5th

For more information, visit our website at www.chicagopubliclibrary.org or call 312-762-2200.



CHICAGO PUBLIC LIBRARY



At The Field Museum

TYRANNOSAURUS



READS

At The Chicago Public Library

SUMMER READING PROGRAM 2000

CO-SPONSORED BY THE FIELD MUSEUM

June 12th - August 5th

For more information, visit our website at www.chicagopubliclibrary.org or call 312-762-2200.



Chicago Streetscape

JCDecaux Chicago

City Information Panel
Stern
Architectural Drawings

Response to Request for Proposal
Specification No. 881557801
JCDecaux Chicago
221 North Dearborn Street #1137
Chicago, IL 60601
Telephone 312.785.3000
Fax 312.785.3618
September 11, 2000

Drawing Title
Plans, Elevations and Sections
Number
Scale
S 1600 001
3/4" = 1' 0"

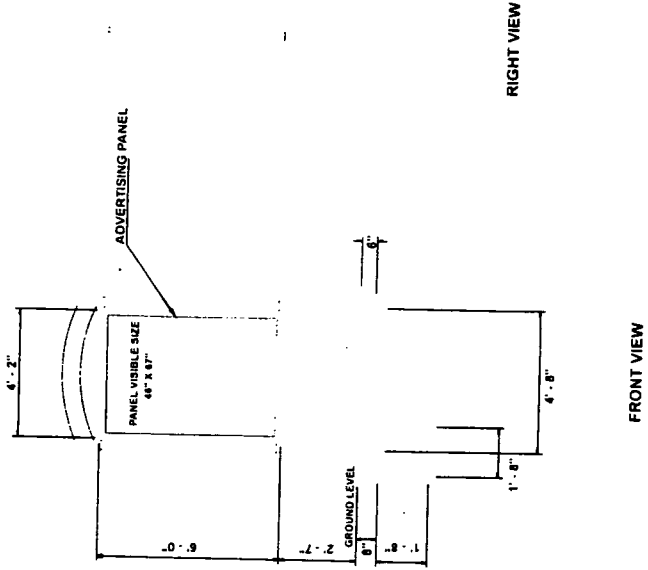
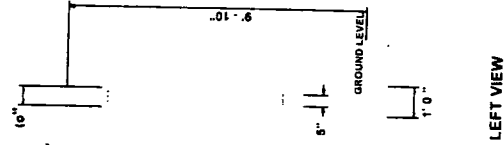
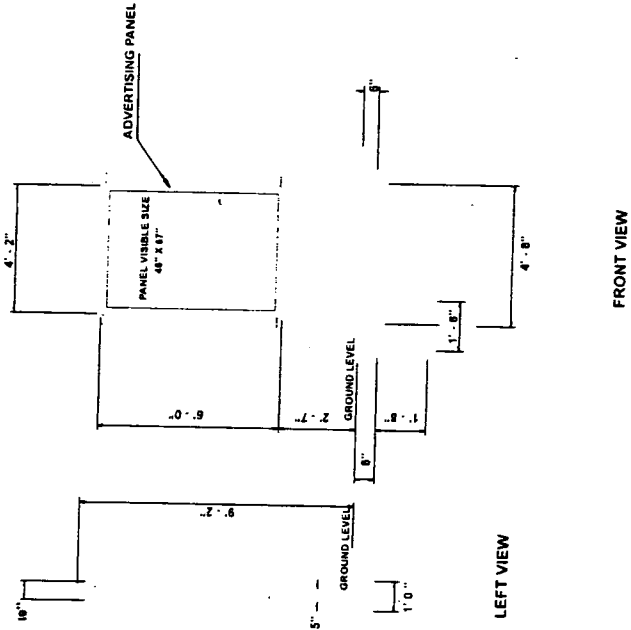
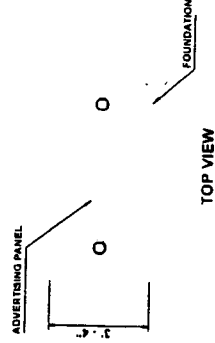
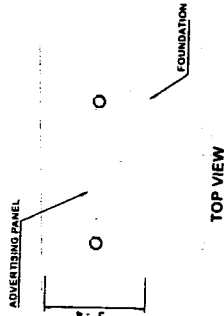

JCDecaux

NEWSRACK

1. GENERAL INFORMATION

Newsracks are designed to consolidate newspaper and magazine street displays. These custom designed units provide a clean and stylish way of dispensing local publications. Each internal display box can accommodate a variety of sizes and styles. The design for the unit is from the HERITAGE line, developed by JCDecaux.

2. TECHNICAL DESCRIPTION

A. FOUNDATION:

Most of the newsracks will be bolted directly onto existing sidewalks or foundations. In some instances new concrete pads will be poured to support the rack.

B. NEWSRACK FEATURES

The standard newsrack is comprised of a metal housing with cast columns on each side. The columns will be painted black with silver accents. Newspaper boxes and coiners, if necessary, (collectively, the "Newspaper Boxes") are inserted into the housing. Newspaper Boxes are made of metal with Plexiglas fronts for viewing the publication. There will be one overall size for the unit, which will house a combination of pay and free publications: the configuration of the unit will be defined by The City of Chicago. The front door of each individual box will bear the name of the newspaper or publication. The unit will meet all relevant ADA requirements with regards to accessibility.

C. ELECTRICITY

No electrical connection will be required for the newsracks.

JCDecaux

D. MATERIALS

- Aluminum: Cast columns and some miscellaneous components for the internal box.
- Steel: The external housing of unit will be steel as well as the mounting hardware.
- Paint: Baked on powder coat paint will be used on all external components. All external surfaces will be painted black. The only exception will be the silver accents that will be on the columns.
- Plastic: The front cover of the display box will be clear Plexiglas or Acrylic.

E. DIMENSIONS

The approximate dimensions for a standard 12-box newsrack are:

Length: 10-1/2 feet
Width: 2-1/2 feet
Height: 6 feet

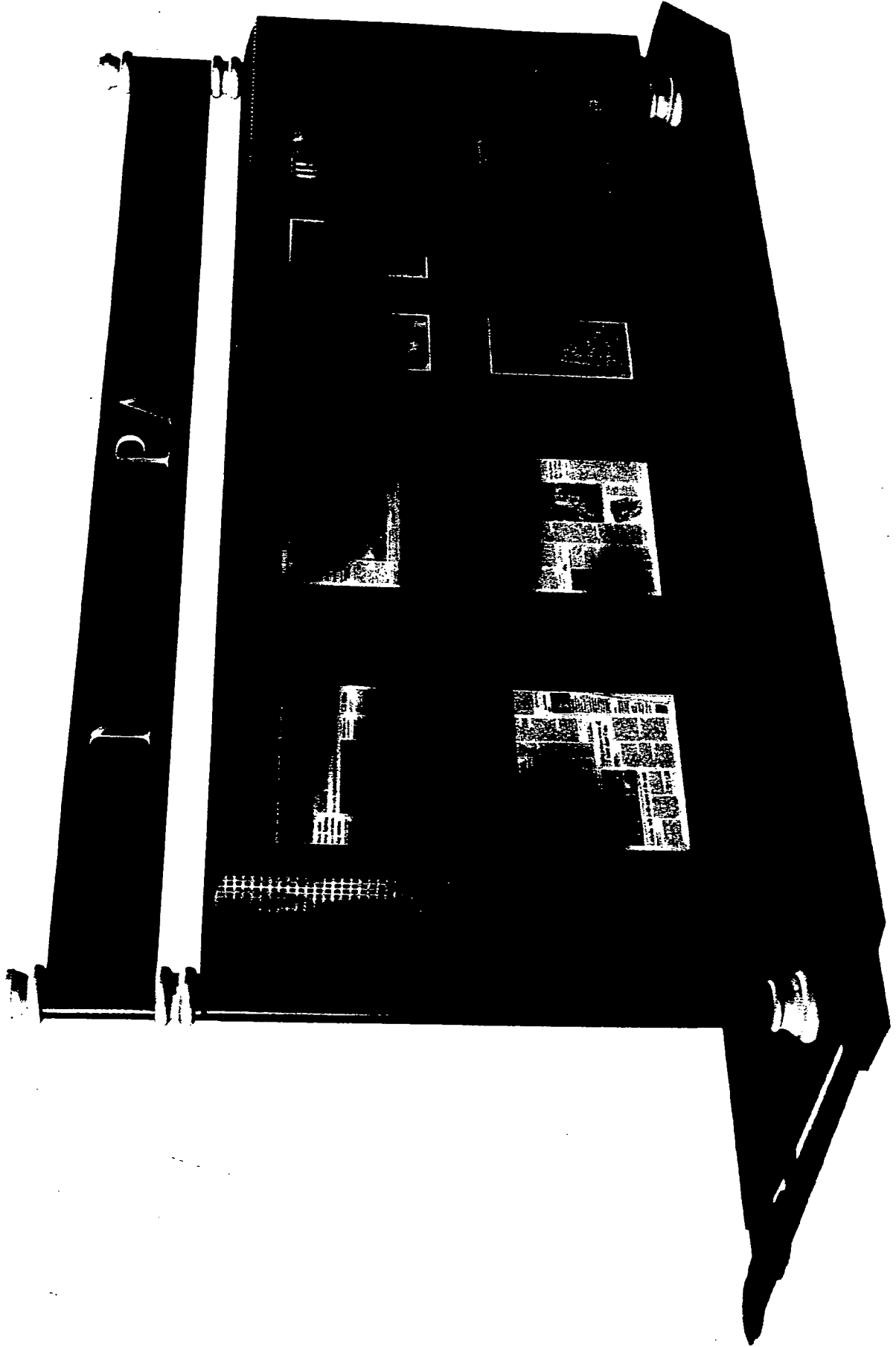

Response to Request for Proposal
Specification No. 88157801

Chicago, Chicago
221 North LaSalle Street #1137
Chicago, IL 60601
Telephone 312 795 3600
Fax 312 795 3618

David E. Malone, Purchasing Agent
Department of Purchases, Contracts & Supplies
City Hall - Bid & Bond Room 401
21 North LaSalle Street
Chicago, IL 60601

September 11, 2000

Drawing Title
Plans, Elevations and Sections
Number
Scale
S 1200 001
3/4" = 1'-0"

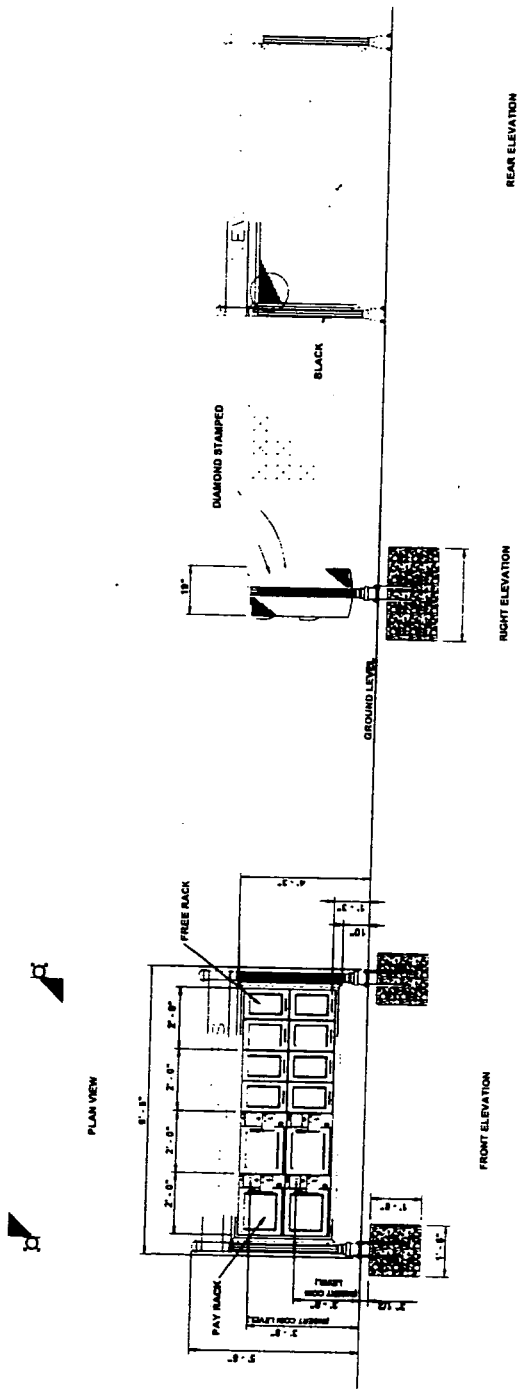



SUPERVISOR KIOSK

1. GENERAL INFORMATION

Each Supervisor Kiosk will accommodate one person, with windows on 3 sides for maximum visibility. The Supervisor Kiosk will protect the CTA Supervisor from the weather while monitoring bus timetables. The Supervisor Kiosk will be manufactured in one standard size. One advertising panel may be integrated on the backside of the unit. One side of the unit has an entrance/exit door for the Supervisor. Each unit is designed in close coordination with the architectural firm Robert A.M. Stern LLP.

2. TECHNICAL DESCRIPTION

A. FOUNDATION:

Chemical anchors will be used to bolt the Supervisor Kiosk directly onto new concrete foundations. The foundations are made of concrete with a minimum strength of 3000 PSI.

B. SUPERVISOR KIOSK FEATURES

The exterior components of the Supervisor Kiosk are comprised of metal, fibreglass, and glass. The City of Chicago emblem may be incorporated into the top of the fixture. The unit will have some silver accents on the top, base, and column sections. The door and window on the unit may be locked when the kiosk is not being used. Glass panels will cover the advertising face.

C. ELECTRICITY/PHONE

Electrical connections will be made on the fixtures that require lighting. GFCI circuit breakers will be used for the lightbox and control box connections. All electrical connections will be made according to the City of Chicago electrical code. Phone-outlet(s) will also be installed as required by the City.

JCDecaux

D. MATERIALS

- Aluminum:** Extrusions and castings will be used for both internal and external components.
- Steel:** Steel sheet metal and machined components will be part of the column. All mounting hardware will be stainless steel to prevent corrosion.
- Paint:** Baked on powder coat paint will be used on all external components. The external surfaces will be painted black. The only exception will be miscellaneous silver accents.
- Fibreglass:** A portion of the custom top will be manufactured by a fibreglass process.
- Glass:** Protective tempered glass will be used to cover the lighted advertisement and for all of the windows.

E. DIMENSIONS

The approximate closed base dimensions for a Supervisor Kiosk are:

- Length:** 4 feet
Width: 4 feet
Height: 9 feet



Bus Supervisor Kiosk
Stern
Architectural Drawings

Response to Request for Proposal
Specification No. 891557601
David E. Malone, Purchasing Agent
Department of Purchases, Contracts & Supplies
131 North Dearborn Street
Chicago, IL 60602

JCDecaux Chicago
221 North LaSalle Street #1137
Chicago, IL 60601
Telephone 312.793.3000
Fax 312.793.3018
September 11, 2000

Drawing Title
Plans, Elevations and Sections
Number
S 1700.001
Scale
3/4" = 1' 0"

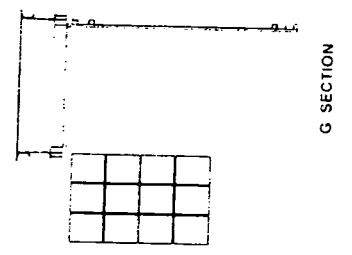
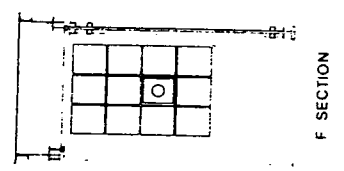
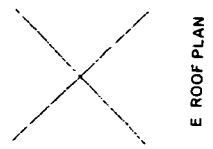
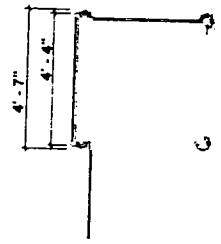
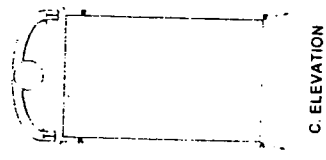
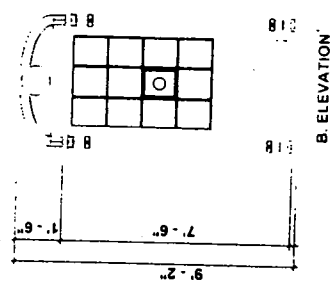
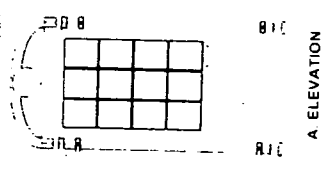

JCDecaux

NEWSSTAND

1. GENERAL INFORMATION

Newsstands will be used by local vendors to sell newspapers, magazines, snack foods and other merchandise authorized by the City. Newsstands will be manufactured in one standard size with up to 3 advertising panels (one on each side of the unit, excluding the front side). The doors slide open during operating hours. The front of the unit will have an overhang to protect customers from the weather. Each unit is designed in close coordination with the architectural firm Robert A.M. Stern LLP.

2. TECHNICAL DESCRIPTION

A. FOUNDATION:

Newsstands will be bolted directly onto new concrete pads. Chemical anchors will be used to bolt to the pad. The concrete foundation will have a minimum strength of 3000 PSI.

B. NEWSSTAND FEATURES

The exterior components of the Newsstands are metal and glass. The City of Chicago emblem may be incorporated into the top of the unit. The unit will have some silver accents on the top, base, and column sections. The doors may be locked when the Newsstand is not being used. Tempered glass panels will cover the advertising surfaces of the unit. The Newsstand will be designed to withstand a minimum wind load of 30/lbs/ft². The unit meets all relevant ADA requirements, for both the vendor and the customers.

C. ELECTRICITY

All electrical connections will be made according to the City of Chicago electrical code. For safety purposes GFCI circuit breakers will be used to connect to the light box and control box.

JCDecaux

D. MATERIALS

- Aluminum: Extrusions and casting will be used for both internal and external components.
- Steel: Steel sheet metal and machined components will be part of the column. All mounting hardware will be stainless steel to prevent corrosion.
- Paint: Baked on powder coat paint will be used on all external components. All external surfaces will be painted black. The only exception will be miscellaneous silver accents.
- Plastic: Some of the viewing panels and display fixtures will be partially made from clear Plexiglas or Acrylic.
- Glass: Protective tempered glass will cover the lighted advertisements.
- Wood: Wood shelving and partitions will make up part of the internal structure.

E. DIMENSIONS

The approximate closed base dimensions for a Newsstand are:

Length: 8 - ½ feet
Width: 6 feet
Height: 9 feet

Drawing Title

JCDecaux Chicago
271 North LaSalle Street #1137
Chicago, IL 60601

Response to Request for Proposal
Specification No. B1557601

Plans, Elevations and Sections

David E. Malone, Purchasing Agent
171 North LaSalle Street
Chicago, IL 60602

City Hall - 1st Floor
City Hall - 1st Floor
Chicago, IL 60602

Number

S 1300.001

September 11, 2000

Scale

3/4" = 1' - 0"

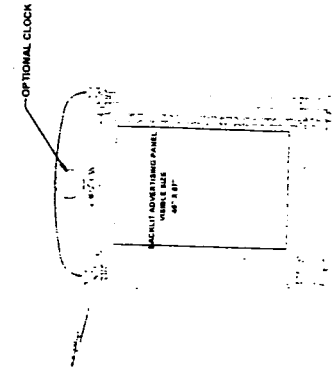
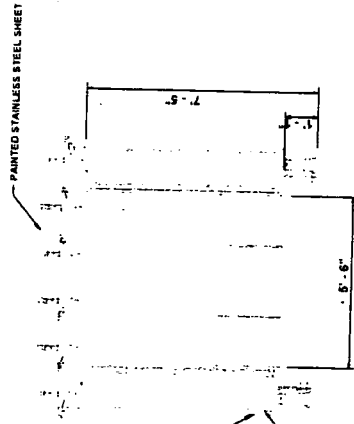
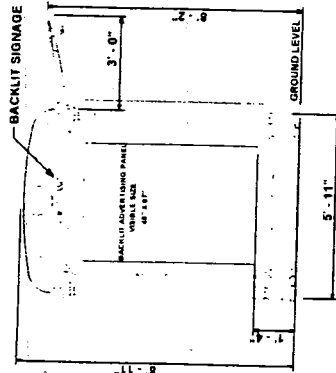

SIDE ELEVATION

FRONT ELEVATION

SIDE ELEVATION

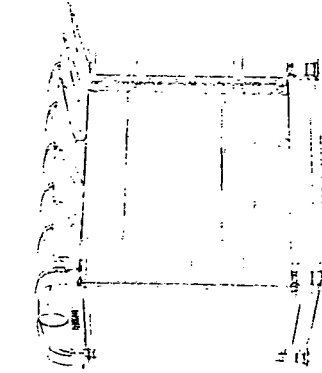
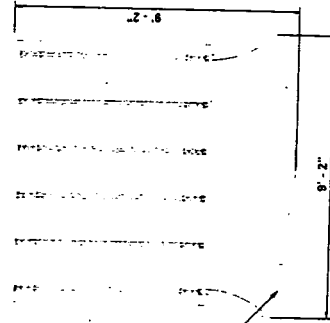
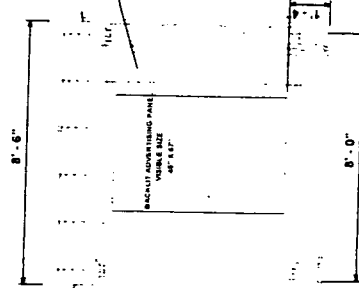

FRONT ELEVATION

SIDE ELEVATION

SIDE ELEVATION

REAR ELEVATION

ROOF VIEW



CAFÉ KIOSK

1. GENERAL INFORMATION

The Café Kiosk will be predominantly located in Parks and will house local vendors who can sell food and drinks to the public. The Café Kiosk will have multiple walk-up windows to accommodate customers. The Café Kiosk is made with high quality materials designed to stand up to a variety of weather conditions. Each unit is designed in close coordination with the architectural firm Robert A.M. Stern LLP.

2. TECHNICAL DESCRIPTION

A. FOUNDATION:

All of the Café Kiosks will be mounted to new foundations. Chemical anchors will be used for the mounting. The concrete foundations will have a minimum strength of 3000 PSI. Trenching will be required to make electrical and plumbing connections.

B. CAFÉ KIOSK FEATURES

The Café Kiosk is comprised of a metal curved roof that is supported by tubular columns and structural walls. The Café Kiosk design meets the City's wind exertion requirements. The design will also meet a minimum static roof load of 30lbs/ft². The kiosk can be locked overnight, when it is not in operation. Lighting is installed on the inside of the unit. All of the equipment connections required for a small café are incorporated into the construction. The unit meets all relevant ADA requirements, for both the vendor and the customers.

C. ELECTRICITY

Fluorescent lamps are used to light the advertising panel. All electrical connections will be made according to the electrical code specifications required by the City of Chicago. Safety features such as GFCI circuit breakers will be used for all lightbox and control box connections.

JCDecaux

D. PLUMBING

Plumbing connections will be made to access water for cleaning and cooking. All connections will be made in accordance with plumbing code specifications of the City of Chicago.

E. MATERIALS

- Aluminum: Extrusion will be used for portions of the roof, diffuser, frame, and doors. Column accents and roof supports will be cast in various shapes and sizes.
- Steel: Steel sheet stock will be incorporated into the roof. Columns will be galvanized steel.
- Paint: Baked on powder coat paint will be used on all external components. The roof, columns, and lightbox will be painted black. Miscellaneous accents on the kiosk will be painted silver.
- Wood: Some internal shelving will be made from wood materials.
- Glass: Tempered safety glass will be used for external glass coverings.
- Plastic: Plexiglass or Acrylic materials will be used to manufacture small internal viewing windows.

F. DIMENSIONS

The approximate dimensions (design still under review) for the Café Kiosk are:

- Length: 14-1/2 feet
Width: 14-1/2 feet
Height: 9-1/2 feet

Chicago Streetscape

JCDecaux Chicago

Cafe Kiosk
Stern
Architectural Drawings

Request to Request for Proposal
Specification No. 091271001
JCDecaux Chicago
221 North LaSalle Street #1137
Chicago, IL 60601
Phone: 312.776.3000
Fax: 312.776.3016
September 11, 2000

Drawing Title
Plans, Elevations and Sections
Number
S 1600 001
Scale
3/4" = 1' 0"

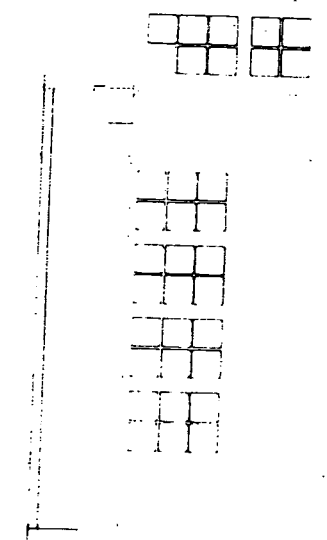
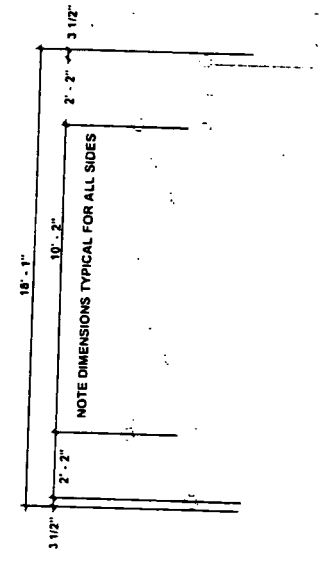
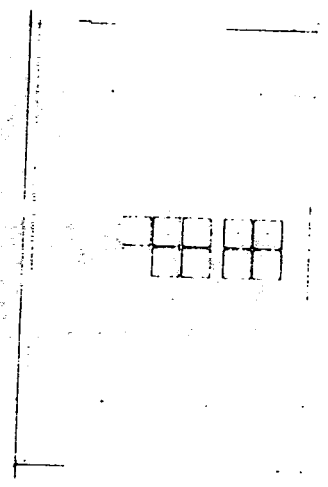
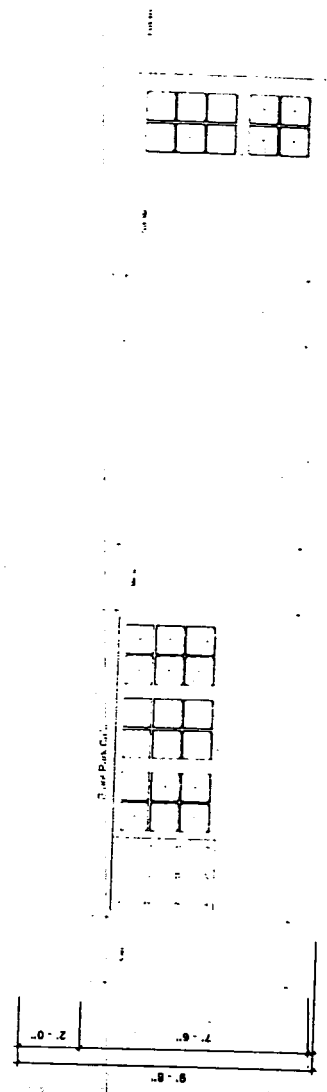

EXHIBIT 1B

Street Furniture Sites

Exhibit 1B
Central Business District
CBD - A Sites

#	UNIT TYPE	JCD unit id#	Site	INTERSECTION	
1	Bus Stop	5	A	Clark	Van Buren
2	Bus Stop	11	A	Franklin	Jackson
3	Bus Stop	12	A	Jackson	Franklin
4	Bus Stop	37	A	Adams	Wells
5	Bus Stop	40	A	Jackson	Financial Pl.
6	Bus Stop	41	A	Jackson	Dearborn
7	Bus Stop	42	A	Jackson	State
8	Bus Stop	43	A	Jackson	Wabash
9	Bus Stop	45	A	Adams	Wacker Drive
10	Bus Stop	54	A	Michigan	Congress
11	Bus Stop	55	A	Congress Plaza Dr.	Michigan
12	Bus Stop	68	A	State	Van Buren
13	Bus Stop	85	A	Michigan	Congress Plaza Dr.
14	Bus Stop	91	A	Dearborn	Congress
15	Bus Stop	95	A	Dearborn	Van Buren
16	Bus Stop	508	A	State	Van Buren
17	Bus Stop	167	A	Chicago	Orleans
18	Bus Stop	842	A	Chicago	Franklin
19	Bus Shelter	1	A	Clark	Randolph
20	Bus Stop	2	A	Clark	Madison
21	Bus Stop	3	A	Clark	Adams
22	Bus Stop	6	A	LaSalle	Haddock Place
23	Bus Stop	8	A	LaSalle	Randolph
24	Bus Stop	18	A	Michigan	Ohio
25	Bus Stop	19	A	Dearborn	Randolph
26	Bus Stop	22	A	Washington	Franklin
27	Bus Stop	23	A	Washington	LaSalle
28	Bus Stop	24	A	Washington	Dearborn
29	Bus Stop	26	A	Washington	Wabash (mid-block)
30	Bus Stop	28	A	Randolph	Michigan
31	Bus Stop	29	A	Madison	Clark
32	Bus Stop	30	A	Madison	Wells
33	Bus Stop	31	A	Madison	Wacker Drive
34	Bus Stop	35	A	Adams	Wabash
35	Bus Stop	36	A	Adams	Clark
36	Bus Stop	56	A	Michigan	Wrigley Building
37	Bus Stop	58	A	Michigan	Huron
38	Bus Stop	59	A	Michigan	Erie
39	Bus Stop	60	A	Michigan	Chicago / Superior
40	Bus Stop	61	A	Michigan	Ontario
41	Bus Stop	62	A	Dearborn	Adams / Jackson
42	Bus Stop	63	A	Dearborn	Monroe
43	Bus Stop	64	A	Dearborn	Madison
44	Bus Stop	65	A	Dearborn	Washington
45	Bus Stop	66	A	Chicago	Mies Van Der Rohe
46	Bus Stop	67	A	Dearborn	Lake
47	Bus Stop	69	A	State	Adams

**Exhibit 1B
Central Business District
CBD - A Sites**

48	Bus Stop	70	A	State	Jackson
49	Bus Stop	71	A	State	Monroe
50	Bus Stop	72	A	State	Madison
51	Bus Stop	73	A	State	Washington
52	Bus Stop	74	A	State	Randolph
53	Bus Stop	75	A	State	Lake
54	Bus Stop	76	A	State	Lake
55	Bus Stop	77	A	Clark	Wacker Drive
56	Bus Stop	80	A	Randolph	Stetson
57	Bus Stop	82	A	LaSalle	Madison
58	Bus Stop	84	A	LaSalle	Quincy
59	Bus Stop	86	A	Chestnut	Mies Van Der Rohe
60	Bus Stop	92	A	Fairbanks	North Water
61	Bus Shelter	96	A	Michigan	Jackson
62	Bus Stop	97	A	Michigan	Monroe
63	Bus Stop	99	A	Michigan	Randolph
64	Bus Stop	100	A	Michigan	Randolph
65	Bus Stop	101	A	Michigan	South Water
66	Bus Stop	102	A	Michigan	Wacker Place
67	Bus Stop	103	A	Michigan	Wacker Drive
68	Bus Stop	104	A	Michigan	Hubbard
69	Bus Stop	106	A	Michigan	Grand
70	Bus Stop	107	A	State	Kinzie
71	Bus Stop	109	A	Michigan	Chicago
72	Bus Stop	111	A	Michigan	Chestnut
73	Bus Stop	112	A	Michigan	Delaware / Walton
74	Bus Stop	113	A	Clark	Carrol
75	Bus Shelter	114	A	Chestnut	Lake Shore Drive
76	Bus Stop	116	A	Michigan	Delaware Place
77	Bus Stop	117	A	Michigan	Pearson
78	Bus Shelter	118	A	Chicago	Michigan
79	Bus Shelter	120	A	Clark	Delaware Place
80	Bus Stop	122	A	Michigan	Illinois
81	Bus Stop	123	A	Wacker Place	Macche / Michigan
82	Bus Stop	124	A	Wacker Place	Wabash
83	Bus Stop	126	A	Clark	Chicago
84	Bus Stop	127	A	Clark	Huron
85	Bus Stop	128	A	Clark	Ontario
86	Bus Stop	129	A	Clark	Grand
87	Bus Stop	130	A	Clark	Hubbard
88	Bus Stop	132	A	Dearborn	Illinois
89	Bus Stop	134	A	Dearborn	Huron
90	Bus Stop	138	A	Grand	Rush
91	Bus Stop	139	A	State	Chicago
92	Bus Stop	141	A	State	Chicago / Superior
93	Bus Shelter	142	A	Chicago	State
94	Bus Stop	143	A	State	Ontario / Erie
95	Bus Stop	144	A	LaSalle	Chicago
96	Bus Stop	145	A	Dearborn	Delaware Place
97	Bus Stop	147	A	Grand	State
98	Bus Stop	152	A	Dearborn	Chicago
99	Bus Stop	153	A	Michigan	Oak

**Exhibit 1B
Central Business District
CBD - A Sites**

100	Bus Stop	154	A	Chicago	Rush
101	Bus Shelter	157	A	Chicago	State
102	Bus Shelter	160	A	Chicago	Clark
103	Bus Stop	161	A	Chicago	Clark
104	Bus Stop	162	A	Chicago	LaSalle
105	Bus Stop	163	A	Chicago	LaSalle
106	Bus Stop	166	A	Chicago	Franklin
107	Bus Stop	174	A	Orleans	Chicago
108	Bus Stop	176	A	Wells	Hubbard
109	Bus Stop	177	A	Orleans	Hubbard
110	Bus Stop	178	A	Orleans	Grand
111	Bus Stop	179	A	LaSalle	Grand
112	Bus Stop	180	A	LaSalle	Illinois
113	Bus Stop	181	A	LaSalle	Grand
114	Bus Stop	182	A	LaSalle	Ontario
115	Bus Stop	183	A	LaSalle	Erie / Ontario
116	Bus Stop	184	A	LaSalle	Huron
117	Bus Stop	185	A	LaSalle	Huron / Superior
118	Bus Stop	186	A	LaSalle	Chicago
119	Bus Stop	187	A	LaSalle	Chestnut
120	Bus Shelter	189	A	LaSalle	Oak
121	Bus Stop	190	A	LaSalle	Delaware Place
122	Bus Stop	193	A	LaSalle	Hubbard
123	Bus Stop	194	A	LaSalle	Kinzie
124	Bus Stop	196	A	Wells	Grand
125	Bus Stop	198	A	Illinois	LaSalle
126	Bus Stop	199	A	Illinois	Clark
127	Bus Stop	201	A	Illinois	State
128	Bus Stop	203	A	Illinois (LL)	Michigan (LL)
129	Bus Stop	204	A	Illinois	Fairbanks
130	Bus Shelter	208	A (*)	Grand	Streeter
131	Bus Stop	209	A	Grand	Orleans
132	Bus Stop	210	A	Grand	McClurg
133	Bus Stop	221	A	Lake Shore Drive	Pearson
134	Bus Shelter	222	A	Pearson	Dewitt
135	Bus Stop	225	A	Fairbanks	Erie
136	Bus Stop	226	A	Fairbanks	Superior
137	Bus Stop	227	A	Fairbanks	Superior
138	Bus Stop	229	A	Fairbanks	Erie
139	Bus Stop	230	A	Fairbanks	Ohio
140	Bus Stop	231	A	Fairbanks	Illinois
141	Bus Stop	235	A	Ontario	Fairbanks
142	Bus Stop	236	A	Ontario	St Clair
143	Bus Stop	240	A	Chicago	Michigan
144	Bus Stop	241	A	Chicago	Mies Van Der Rohe
145	Bus Stop	242	A	Mies Van Der Rohe	Chicago
146	Bus Shelter	333	A	Clark	Oak
147	Bus Stop	334	A	Chicago	Fairbanks
148	Bus Stop	335	A	Fairbanks	Chicago
149	Bus Stop	336	A	Grand	Fairbanks
150	Bus Stop	337	A	State	Grand
151	Bus Shelter	338	A	Wells	Merchandise Mart Plaza

**Exhibit 1B
Central Business Distri
CBD - A Sites**

152	Bus Stop	340	A	Dearborn	Kinzie
153	Bus Stop	341	A	Wacker Drive	Michigan
154	Bus Stop	342	A	Wacker Drive	Wabash
155	Bus Stop	343	A	State	Wacker Drive
156	Bus Stop	344	A	Clark	Lake
157	Bus Stop	345	A	Washington	State
158	Bus Stop	346	A	Madison	Wabash
159	Bus Stop	347	A	Dearborn	Adams
160	Bus Stop	432	A	Clark	Oak
161	Bus Shelter	454	A	Lasalle	Oak
162	Bus Shelter	501	A	Orleans	Merchandise Mart Plaza
163	Bus Stop	505	A	Adams	State
164	Bus Stop	506	A	State	Maple
165	Bus Stop	510	A	Madison	State
166	Bus Stop	511	A	Michigan	Monroe
167	Bus Stop	757	A	Michigan	Madison
168	Bus Stop	799	A	LaSalle	Haddock Place
169	Bus Stop	809	A	Michigan	Washington
170	Bus Stop	841	A	LaSalle	River
171	Bus Stop	843	A	Chicago	Dearborn
172	Bus Stop	339	A	LaSalle	Carroll
173	Bus Stop	433	A	Clark	Maple
174	Bus Stop	15	A	Franklin	Washington
175	Bus Stop	453	A	LaSalle	Maple
176	Bus Stop	13	A	Franklin	Adams
177	Bus Stop	14	A	Franklin	Madison
178	Bus Stop	170	A	Orleans	Oak
179	Bus Stop	171	A	Orleans	Locust
180	Bus Stop	172	A	Orleans	Locust
181	Bus Stop	16	A	Franklin	Randolph
182	Bus Stop	151	A	Wells	Huron
183	Bus Stop	175	A	Orleans	Erie
184	Bus Stop	195	A	Wells	Ontario
185	Bus Stop	219	A	Grand	Franklin
186	Bus Stop	434	A	Clark	Maple

**NOTE = Sites #176 through #186 above are the CBD - A ALTERNATE Sites
(* Site #130 (unit #208 Navy Pier) is treated as a CBD-A**

**Exhibit 1B
Central Business Distri
CBD - B Sites**

#	UNIT TYPE	JCD unit id#	Site	INTERSECTION	
1	Bus Shelter	465	B	Division	
2	Bus Shelter	466	B	Ashland	Ashland
3	Bus Stop	482	B	Ashland	Milwaukee
4	Bus Shelter	549	B	Milwaukee	Grand
5	Bus Stop	824	B	Chicago	Division
6	Bus Stop	831	B	Ashland	Ashland
7	Bus Stop	833	B	Ashland	Augusta
8	Bus Stop	834	B	Ashland	Division
9	Bus Stop	835	B	Ashland	Bauwans
10	Bus Stop	7	B	Clark	Blackhawk
11	Bus Stop	38	B	State	Harrison
12	Bus Stop	50	B	Michigan	Harrison / Congress
13	Bus Stop	52	B	Dearborn	Harrison
14	Bus Stop	57	B	State	Harrison
15	Bus Stop	87	B	State	Harrison / Congress
16	Bus Shelter	88	B	Michigan	Balbo
17	Bus Stop	89	B	Michigan	9th
18	Bus Stop	90	B	Michigan	8th
19	Bus Stop	93	B	Michigan	8th
20	Bus Stop	94	B	Michigan	Balbo
21	Bus Stop	266	B	Canal	Balbo
22	Bus Stop	267	B	Canal	Van Buren / Jackson
23	Bus Stop	269	B	Canal	Jackson / Van Buren
24	Bus Stop	271	B	Canal	Adams
25	Bus Stop	287	B	Adams	Monroe
26	Bus Stop	293	B	Jackson	Canal
27	Bus Stop	315	B	Van Buren	Canal
28	Bus Stop	322	B	Madison	Ashland
29	Bus Stop	328	B	Madison	Aberdeen
30	Bus Shelter	348	B	Balbo	Loomis
31	Bus Shelter	349	B	Columbus Drive	Michigan
32	Bus Shelter	350	B	Columbus Drive	Roosevelt
33	Bus Stop	520	B	State	Roosevelt
34	Bus Stop	524	B	State	14th
35	Bus Stop	525	B	Roosevelt	Roosevelt
36	Bus Shelter	580	B	State	State
37	Bus Stop	600	B	Ashland	9th
38	Bus Shelter	607	B	Ashland	Polk
39	Bus Stop	622	B	Ashland	15th
40	Bus Stop	655	B	Roosevelt	Canal
41	Bus Stop	659	B	Cermak	Michigan
42	Bus Shelter	660	B	Michigan	11th
43	Bus Shelter	661	B	Michigan	11th
44	Bus Shelter	663	B	Michigan	Roosevelt
45	Bus Stop	664	B	Michigan	Roosevelt
46	Bus Stop	666	B	Roosevelt	Michigan
47	Bus Stop	674	B	Michigan	14th
					18th

**Exhibit 1B
Central Business District
CBD - B Sites**

48	Bus Shelter	675	B	Michigan	Cullerton
49	Bus Shelter	680	B	Indiana	15th
50	Bus Shelter	701	B	Halsted	Polk
51	Bus Shelter	702	B	Harrison	Halsted
52	Bus Stop	800	B	Ashland	Roosevelt
53	Bus Stop	801	B	Roosevelt	Racine
54	Bus Stop	802	B	Roosevelt	Clinton
55	Bus Stop	803	B	Roosevelt	Canal
56	Bus Stop	804	B	Ashland	Taylor
57	Bus Stop	805	B	Ashland	Taylor
58	Bus Stop	807	B	Ashland	Polk
59	Bus Stop	808	B	Ashland	Harrison
60	Bus Shelter	810	B	Harrison	Racine
61	Bus Stop	815	B	Halsted	Taylor
62	Bus Stop	351	B	State	16th Street
63	Bus Stop	352	B	State	Cermak
64	Bus Stop	507	B	State	Cullerton
65	Bus Stop	515	B	State	18th
66	Bus Stop	518	B	State	14th Place
67	Bus Stop	575	B	Clark	15th
68	Bus Stop	581	B	Clark	18th
69	Bus Shelter	651	B	Cermak	State
70	Bus Stop	353	B	Halsted	14th Street
71	Bus Stop	354	B	Halsted	14th Street
72	Bus Shelter	356	B	Ashland	Cermak
73	Bus Stop	498	B	Ashland	Harrison
74	Bus Stop	613	B	Ashland	18th
75	Bus Stop	621	B	Ashland	Cermak
76	Bus Shelter	623	B	Cermak	Ashland
77	Bus Shelter	646	B	Cermak	S. Archer
78	Bus Stop	650	B	Archer	Clark
79	Bus Shelter	678	B	Cermak	Clark (below Red Line bridge)
80	Bus Stop	695	B	Halsted	Roosevelt
81	Bus Stop	696	B	Roosevelt	Halsted
82	Bus Shelter	700	B	Halsted	Polk
83	Bus Stop	706	B	Halsted	Harrison
84	Bus Shelter	811	B	Harrison	Morgan
85	Bus Shelter	813	B	Taylor	Morgan
86	Bus Stop	814	B	Halsted	Taylor
87	Bus Shelter	821	B	Ashland	Grand
88	Bus Stop	822	B	Grand	Ashland
89	Bus Stop	168	B	Chicago	Hudson
90	Bus Shelter	169	B	Chicago	Larrabee
91	Bus Stop	282	B	Van Buren	Halsted
92	Bus Stop	290	B	Halsted	Jackson
93	Bus Stop	316	B	Madison	Halsted
94	Bus Stop	319	B	Madison	Morgan
95	Bus Stop	323	B	Madison	Racine
96	Bus Stop	326	B	Madison	Throop
97	Bus Shelter	357	B	Chicago	May

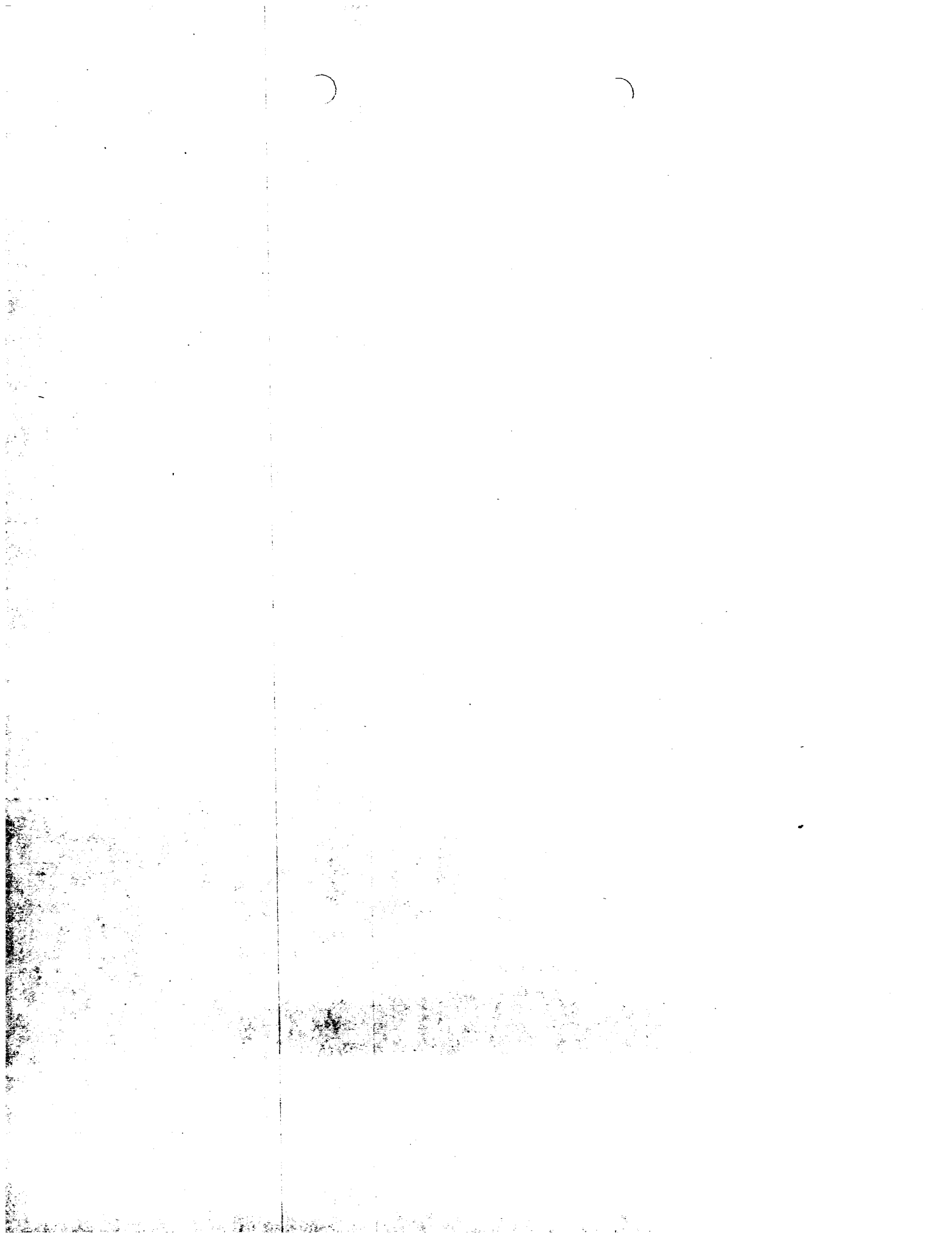

**Exhibit 1B
Central Business Distri
CBD - B Sites**

98	Bus Stop	359	B	Chicago	Ogden
99	Bus Stop	382	B	Halsted	Evergreen
100	Bus Stop	391	B	Halsted	Chicago
101	Bus Shelter	392	B	Chicago	Halsted
102	Bus Stop	407	B	North	Larrabee
103	Bus Stop	471	B	Ashland	Augusta
104	Bus Stop	486	B	Ashland	Lake
105	Bus Stop	490	B	Ashland	Madison
106	Bus Stop	533	B	Division	Sedgwick
107	Bus Stop	540	B	Division	Sedgwick
108	Bus Stop	567	B	Halsted	Clybourn
109	Bus Stop	819	B	Ashland	Madison
110	Bus Stop	825	B	Grand	Ogden
111	Bus Shelter	827	B	Grand	Halsted
112	Bus Stop	828	B	Grand	Milwaukee
113	Bus Stop	561	B	North	Magnolia
114	Bus Stop	247	B	Jefferson	Washington
115	Bus Stop	253	B	Madison	Jefferson / Des Plaines
116	Bus Stop	272	B	Canal	Madison
117	Bus Stop	273	B	Canal	Washington
118	Bus Shelter	274	B	Canal	Randolph
119	Bus Stop	276	B	Clinton	Washington
120	Bus Stop	277	B	Clinton	Madison
121	Bus Stop	295	B	Madison	Clinton
122	Bus Shelter	296	B	Washington	Jefferson
123	Bus Stop	366	B	Chicago	Hudson
124	Bus Stop	425	B	Clark	North
125	Bus Stop	436	B	Clark	Division
126	Bus Stop	438	B	Clark	Division
127	Bus Stop	440	B	Division	Clark
128	Bus Shelter	441	B	Clark	Goethe
129	Bus Stop	442	B	Clark	Goethe
130	Bus Stop	443	B	Clark	Schiller
131	Bus Stop	444	B	Clark	Schiller
132	Bus Shelter	445	B	Clark	Burton
133	Bus Stop	446	B	Clark	Burton
134	Bus Stop	758	B	Lake Shore Drive	Elm
135	Bus Stop	759	B	Lake Shore Drive	Division
136	Bus Shelter	765	B	LaSalle	Division
137	Bus Stop	830	B	Chicago	Larrabee
138	Bus Stop	331	B	North	Wells
139	Bus Stop	419	B	LaSalle	North
140	Bus Shelter	447	B	Lasalle	Burton
141	Bus Shelter	449	B	Lasalle	Schiller
142	Bus Stop	451	B	LaSalle	Goethe
143	Bus Stop	760	B	Lake Shore Drive	Goethe
144	Bus Shelter	761	B	Lake Shore Drive	Banks
145	Bus Shelter	762	B	Lake Shore Drive	Schiller
146	Bus Shelter	763	B	Lake Shore Drive	Burton
147	Bus Shelter	764	B	Lake Shore Drive	North

**Exhibit 1B
Central Business Distri
CBD - B Sites**

148	Bus Stop	767	B	LaSalle	Division
149	Bus Stop	837	B	North	Clybourn
150	Bus Stop	838	B	North	Clybourn
151	Bus Stop	839	B	Division	Larrabee
152	Bus Stop	844	B	North	Sedgwick
153	Bus Stop	564	B	Halsted	Scott
154	Bus Stop	355	B	18th	Blue Island
155	Bus Shelter	684	B	Indiana	14th
156	Bus Stop	768	B	Cermak	Prairie
157	Bus Shelter	812	B	Harrison	Morgan
158	Bus Stop	816	B	Ashland	Van Buren
159	Bus Shelter	817	B	Jackson	Lafin
160	Bus Shelter	823	B	Grand	Noble
161	Bus Shelter	826	B	Chicago	Chicago River
162	Bus Shelter	832	B	Milwaukee	Augusta
163	Bus Stop	836	B	North	Fremont
164	Bus Shelter	829	B	Grand	Chicago River

NOTE = Sites #151 through #164 above are the CBD - B ALTERNATE Sites

EXHIBIT 1B

CHICAGO NEIGHBORHOODS SITES

All existing bus stop shelters in the Chicago Neighborhoods, as of the Commencement Date, are hereby designated as Chicago Neighborhoods Sites. The City will direct the Contractor as to which such sites are the Initial Chicago Neighborhoods Sites.

EXHIBIT 1C

Installation Schedule (Phase I and Phase II)

Note that all times set forth in the Installation Schedule are subject to all time limitations described in the Agreement.

The abbreviation "Q" stands for calendar quarter (i.e., Q1 is January, February and March; Q2 is April, May and June; Q3 is July, August and September; and Q4 is October, November and December). Phase I encompasses Q4 in 2002 and all of 2003 and Phase II encompasses all of 2004.

Street Furniture	Total	2002	2003				2004			
		Q4	Q1	Q2	Q3	Q4	Q1	Q2	Q3	Q4
CBD Bus Shelters	325	20	135	135	35					
Neighborhood Bus Shelters	1850	20	135	135	235	270	270	270	270	245
City Information Panels	75				15	60				
News Racks	110		28		28		27		27	
News Stands	26					13	13			
Bus Supervisor Kiosks	17				7		10			
Café Kiosks	5					5				
Total	2408	40	298	270	320	348	320	270	297	245

EXHIBIT 1D

Maintenance and Operation Standards

Note that all standards described in this Exhibit 1D apply 24 hours per day, 7 days per week, 365 days until the termination or expiration of this Agreement.

I. Maintenance Standards Applicable to All Street Furniture

A. The Contractor must professionally and scrupulously maintain and repair all items of Street Furniture in a first-class manner. Maintenance requirements for Street Furniture include the following:

1. The Contractor will divide the City of Chicago into four or more maintenance regions. Each region will contain approximately the same area, but the proposed boundaries may be revised based upon other factors such as higher concentration of furniture or greater demands for maintenance. Each region will have its own supervisor, technicians, vehicles and warehouse. One central region will act as a central point, coordinating the others.
2. The Contractor will develop and install hardware and software for a computerized inventory and information sharing system on the structure. The system will be PC based, working in a Windows NT environment, or other first-class technology acceptable to the City. The Contractor will supply the City and CTA with two computers, which will be linked to a high availability server at the Contractor's Data Center through a dedicated and secure connection. The system will have a mapping capability, allowing the City and the CTA officials to instantly locate any structure. The system will include the real time data updates collected by the Global Positioning System, including but not limited to the date, time, location and specific maintenance codes for the completed tasks.
3. The Contractor will provide, at its sole expense, a suitable 24 hour per day, 7 day per week connection mechanism to the City of Chicago's 311 system. The Contractor must promptly respond to the City's Work Order and Repair System, which is connected directly to the local 311 system as well as a 24-hour City service number.
4. The Contractor must maintain all Street Furniture in first-class, like-new condition throughout the life of the contract, including refurbishing, reconditioning, and if necessary replacing worn Street Furniture. All maintenance techniques shall be environmentally safe. Any and all replacements of parts or features and maintenance techniques will be accomplished using the most modern standard features and technologies available at the time of replacement.
5. The Contractor must implement a notification process that insures quick response to reports of damage. The City and the CTA must be able to direct complaints, including without limitation complaints that the City receives through its 311 phone number, to a 24-hour contractor notification system. The Contractor must post the 311 phone number on a plate or placard permanently attached to each piece

of Street Furniture to allow the public to report vandalism or damages and each such plate or placard shall identify the piece of Street Furniture by a unique identification number.

6. The Contractor must comprehensively inspect the Street Furniture as necessary, no less than twice per year, for structural integrity (footing, seams, welds, loose bolts, bent/broken frame, leaning structure) and roof and other leaks.

7. The Contractor will maintain routine inspection, cleaning, including removal of stickers and removal of litter within a 5 foot radius around each piece of Street Furniture at least twice a week on non-consecutive days, at least two days apart,. Each inspection will be recorded in the maintenance database using scan-tron or a similar technique. Such cleaning schedule for all Street Furniture must include: washing all glass/Lexan, benches, roofs, framework of structure; replacing broken light bulbs and light bulb casings; replacing etched/broken glass or Lexan; and removing graffiti(paint, markers, stickers, unauthorized posters).

8. The Contractor must maintain surfaces adjacent to and underlying all Street Furniture, keeping such surfaces in a safe, clean, attractive and sanitary condition and in good order and repair.

9. Etching of glass panels will require replacement of the glass if etching affects more than 25 square inches of the panel or is recognizable as letters, numbers, characters or symbols. In the event of repetitive etching of one piece of Street Furniture, the Contractor may submit a written request to the City to replace a glass surface with a more durable surface such as Lexan, fiberglass or metal mesh, which request the City will not unreasonably deny.

10. Ice and snow removal must begin within one hour after first report or first snowfall and must continue with diligence throughout the snowfall, and be completed within 24 hours of end of snowfall, throughout the winter, regardless of number of snowfalls. Removal of snow and ice will include a four-foot radius surrounding each piece of furniture and clearance to the curb for Bus Stop Shelters specifically. Snow may not be discarded in the public way and must be removed from the vicinity.

11. At any time during the day or night, the Contractor guarantees a 1-hour response time to remove any broken glass and a 24-hour response time to repair or replace broken glass. The Contractor must demonstrate zero tolerance toward graffiti and the Contractor guarantees a 24-hour response time to remove graffiti.

12. The Contractor guarantees 24-hour maintenance of all Bus Stop Shelters and other Street Furniture. All repairs and replacement of parts must be completed within 24 hours after report of condition requiring repair.

13. The Contractor must remove and replace any damaged piece of Street Furniture that can not be repaired on-site within 48 hours of notification or inspection, except to the extent the Project Manager has determined there are unusual and unforeseeable circumstances and grants an extension in such time frame upon the request of the Contractor.

14. In addition to the Deliverables required by the Agreement, the Contractor must maintain accurate records and databases, accessible by the City and the CTA, including: (a) a Contractor maintained database of Bus Stop Shelters and other Street Furniture that can be electronically mapped at any time and that includes information regarding installation, maintenance, repair and response times for online review at any time by the CTA or the City; (b) monthly maintenance/repair logs and a monthly written report (provided in hard copy and electronic format) that includes a description of repair work on any Street Furniture, response time, cost of repair, cost of individual parts for repair, cost of labor and reports of emergencies (e.g., car accidents, destruction of Street Furniture, loose footings, injuries to public, etc.) and response times.

15. To the extent feasible, all routine maintenance must be performed between 8:00 p.m. and 6:00 a.m. within the Central Business District and 9:30 a.m. and 3:00 p.m. outside of the Central Business District, unless written consent is obtained from the City in advance. The Contractor must not obstruct traffic when performing maintenance at any time.

16. The Contractor must perform a visual electrical inspection as necessary, no less than three times per year, with periodic testing of electrical systems and grounding test after installation as necessary, no less than once every four years thereafter, and shall check the lighting system at night as necessary, no less than twice per month at half month intervals.

B. Maintenance and Operations Submission. To the extent not inconsistent with the above requirements, the Contractor will comply with the 52-week preventative maintenance plan attached to this Agreement as Exhibit 1E.

II. Maintenance Standards Applicable to Newsracks

A. Contractor must regularly clean, maintain and repair the exterior (other than the "Coiner") of the Newsracks and must remove therefrom all unauthorized posters, graffiti and dirt. "Coiner" means the coin vending mechanisms of the Newsracks and any other components which are in the exclusive control of the publications which are distributed from the Newsracks. Contractor's maintenance obligations include repairs and maintenance to Newsracks necessitated by any cause, including vandalism. If, however, a Newsrack has suffered Substantial Damage, the Contractor may request City authorization to relocate such Newsrack in accordance with Section 4.9(b) of the Agreement.

B. The Contractor must commence and diligently pursue repairs within two hours of notice from the City stating the need for a repair described below, when such notice is sent between Monday through Friday, 5:00 a.m. to 10:00 a.m. If such notice is not sent during such time period, the Contractor must commence and diligently pursue repairs no later than 2 hours of notice from the City, or 7:00 a.m., whichever is later. Such repairs include:

1. repair of malfunction of or damage to one or more of the boxes for newspapers and periodicals ("Newsbox") that is part of a Multiple Newsrack.

2. repair any inoperable Newsbox, except when the inoperability results from a defect, malfunction or other problem with the Coiner; and

3. if the inoperability is due to the Coiner or requires the removal of a Newsbox, the two hour period will not begin until the applicable publication gives the Contractor access to the Coiner.

C. The Contractor must perform the following work by 5:00 a.m. on the business day following notice from the City stating the need for a service described below:

1. remove and deliver to a location selected by the City any free standing newspaper and periodical vending machine that is within 200 feet of a Newsrack or illegally in a "multiple newsrack area," as that term is described in Chapter 10-28 of the Municipal Code of Chicago. For purposes of this paragraph C.1., "notice" means written notice;

2. remove any graffiti or posters on the Multiple Newsracks; and

3. remove any extraneous objects chained or attached to a Multiple Newsrack.

D. Notwithstanding the foregoing, (i) if any extraneous object is chained or attached to a Newsrack and interferes with the operation of the Newsrack, the Contractor must remove the object within two hours of notice from City, and (ii) if for any reason an entire Newsrack must be replaced, the Contractor must replace it within 24 hours of removing it.

E. The Contractor is not be responsible for keeping each Newsbox supplied with authorized publications, or with cleaning the interior of Newsboxes or with repairing the Coiner of each Newsbox.

F. If the City determines work is required to eliminate imminent physical danger to the public, or for other reasons of public safety requiring emergency response, then it may carry out such work immediately and give notice of the same forthwith to the Contractor and the City may recover its reasonable costs from the Contractor. Payment is due upon demand by the City.

G. The Contractor must forward to the City any written complaints it has received regarding Newsboxes within one business day of receipt. In addition, the Contractor must maintain a log of non-written complaints it receives and submit a copy of the log to the City on a weekly basis. The format of the log will be provided by the City.

EXHIBIT 1E

Preventative Maintenance Plan

EXHIBIT 2

Contractor Fee Schedule and Abatement Schedule

<u>Calendar</u> <u>Year</u>	<u>Fee</u>
2002	\$1,500,000
2003	\$1,636,364
2004	\$1,636,364
2005	\$3,863,636
2006	\$3,863,636
2007	\$3,863,636
2008	\$10,318,182
2009	\$10,318,182
2010	\$10,318,182
2011	\$10,318,182
2012	\$10,318,182
2013	\$17,954,545
2014	\$17,954,545
2015	\$17,954,545
2016	\$17,954,545
2017	\$17,954,545
2018	\$29,954,545
2019	\$29,954,545
2020	\$29,954,545
2021	\$29,954,545
2022	<u>\$29,954,545</u>
Total	\$307,500,000

ABATEMENT SCHEDULE

1) Point value per structure

Structure Type	Ad Panels	Points Per Structure		
		CBD-A	CBD-B	C
Bus Shelters with scrolling advertising panel	4	24	10	4
Bus Shelters with fix advertising panel	2	12	5	2
City Information Panel	3	18	7.5	3
Café Kiosks and Newsstands with advertising	3	18	7.5	3
Supervisor Kiosks with advertising	1	6	2.5	1

A: CBD-A

B: CBD-B

C: Chicago Neighborhoods

2) Annual Abatement Per Missing Average Point

Year*	Average Points	Maximum Compensation	Abatement Amount
2003	5,777	\$1,636,364	\$283
2004	9,408	\$1,636,364	\$174
2005	9,855	\$3,863,636	\$392
2006	9,855	\$3,863,636	\$392
2007	9,855	\$3,863,636	\$392
2008	9,855	\$10,318,182	\$1,047
2009	9,855	\$10,318,182	\$1,047
2010	9,855	\$10,318,182	\$1,047
2011	9,855	\$10,318,182	\$1,047
2012	9,855	\$10,318,182	\$1,047
2013	9,855	\$17,954,545	\$1,822
2014	9,855	\$17,954,545	\$1,822
2015	9,855	\$17,954,545	\$1,822
2016	9,855	\$17,954,545	\$1,822
2017	9,855	\$17,954,545	\$1,822
2018	9,855	\$29,954,545	\$3,040
2019	9,855	\$29,954,545	\$3,040
2020	9,855	\$29,954,545	\$3,040
2021	9,855	\$29,954,545	\$3,040
2022	9,855	\$29,954,545	\$3,040

* 2002 Payment not subject to Abatement

3) Annual Abatement Calculation

Repeat calculation for each type of structure and sum for total Annual Abatement

**Annual Abatement Amount for Each Type of Structure =
 Points Per Structure x Abatement Amount / 365 x Number of Days of Abatement
 x Number of Structures**

EXHIBIT 3

MBE/WBE Special Conditions

SPECIAL CONDITION REGARDING MINORITY BUSINESS ENTERPRISE COMMITMENT AND WOMEN BUSINESS ENTERPRISE COMMITMENT

1. Policy and Terms

- A. It is the policy of the City that Local Businesses certified as Minority Business Enterprises (MBE) and Women Business Enterprises (WBE) in accordance with Section 2-92-420 *et seq.* of the Municipal Code of Chicago and Regulations Governing Certification of Minority and Women-owned Businesses, and all other Regulations promulgated under the aforementioned sections of the Municipal Code shall have the maximum opportunity to participate fully in the performance of this agreement. Therefore, the contractor shall not discriminate against any person or business on the basis of race, color, national origin or sex, and shall take affirmative action to ensure that women and minority businesses shall have the maximum opportunity to compete for and perform subcontracts for supplies or services.

The Chief Procurement Officer has established a goal of awarding not less than 25 % of the annual dollar value of all contracts to certified MBEs and 5 % of the annual dollar value of all contracts to certified WBEs.

- B. The contractor has committed to expend at least the following percentages of the total contract price (inclusive of any and all modifications and amendments) for contract participation by MBEs and WBEs:

<u>MBE Percentage</u>	<u>WBE Percentage</u>
31 %	6 %

- C. This commitment is met by the contractor's status as a MBE or WBE, or by a joint venture with one or more MBEs or WBEs as prime contractor (to the extent of the MBE or WBE participation in such joint venture), or by subcontracting a portion of the work to one or more MBEs or WBEs, or by the purchase of materials used in the performance of the contract from one or more MBEs or WBEs, or by the indirect participation of MBEs or WBEs in other aspects of the contractor's business (but no dollar of such indirect MBE or WBE participation shall be credited more than once against a contractor's MBE or WBE commitment with respect to all contracts of such contractor), or by any combination of the foregoing. Note: MBE/WBE participation goals are separate and those businesses certified with the City as both a MBE/WBE shall not be credited more than once against a contractor's MBE or WBE commitment in the performance of the contract.

- D. As noted above, the contractor may meet all or part of this commitment by contracting with MBEs or WBEs for the provision of goods or services not directly related to the performance of this contract. However, in determining the manner of MBE/WBE participation, the contractor shall first consider involvement of MBEs/WBEs as joint venture partners, subcontractors, and suppliers of goods and services directly related to the performance of this contract. In appropriate cases, the Chief Procurement Officer will require the contractor to demonstrate the specific efforts undertaken by it to involve MBEs and WBEs directly in the performance of this contract.
- E. The contractor also may meet all or part of this commitment through credits received pursuant to Section 2-92-530 of the Municipal Code of Chicago for the voluntary use of MBEs or WBEs in private sector projects.

2. Definitions

- A. **“Minority Business Enterprise” or “MBE”** means a firm awarded certification as a minority owned and controlled business in accordance with City Ordinances and Regulations.
- B. **“Women Business Enterprise” or “WBE”** means a firm awarded certification as a women owned and controlled business in accordance with City Ordinances and Regulations.
- C. **“Directory”** means the Directory of Certified “Disadvantaged Business Enterprises,” “Minority Business Enterprises” and “Women Business Enterprises” maintained and published by the Contract Compliance Administrator. The Directory identifies firms that have been certified as MBEs and WBEs, and includes both the date of their last certification and the area of specialty in which they have been certified. Contractors are responsible for verifying the current certification status of all proposed MBE and WBE firms.
- D. **“Area of Specialty”** means the description of a MBE or WBE firm’s business which has been determined by the Chief Procurement Officer to be most reflective of the MBE or WBE firm’s claimed specialty or expertise. Each MBE/WBE letter of certification contains a description of its Area of Specialty. This information is also contained in the Directory. Credit toward this contract’s MBE and WBE participation goals shall be limited to the participation of firms performing within their Area of Specialty.

NOTICE: The City does not make any representation concerning the ability of any MBE/WBE to perform work within their Area of Specialty. It is the responsibility of all contractors to determine the capability and capacity of MBEs/WBEs to satisfactorily perform the work proposed.

- E. **“Joint Venture”** means an association of two or more businesses to carry out a single business enterprise for profit, and for which purpose they combine their expertise, property, capital, efforts, skill and knowledge. Contractors may develop joint venture agreements as an instrument to provide participation by MBEs and WBEs in contract work. A joint venture seeking to be credited for

MBE/WBE participation may be formed among certified MBE/WBE firms or between certified MBE/WBE firm (s) and non-MBE/WBE firm(s).

A joint venture is eligible for MBE/WBE credit if the MBE/WBE partner(s) share in the ownership, control, management responsibilities, risks and profits of the joint venture, and are responsible for a clearly defined portion of work to be performed, in proportion with the MBE/WBE ownership percentage.

F. **“Contract Compliance Administrator”** means the officer appointed pursuant to Section 2-92-490 of the Municipal Code of Chicago.

3. **Counting MBE/WBE Participation Toward the Contract Goals**

A. The inclusion of any MBE or WBE in the contractor’s MBE/WBE Utilization Plan shall not conclusively establish the contractor’s right to full MBE/WBE credit for that firm’s participation in the contract.

B. The Chief Procurement Officer reserves the right to deny or limit MBE/WBE credit to the contractor where any MBE or WBE is found to be engaged in substantial subcontracting or pass-through activities with others. In this regard, a contractor may count toward its MBE and WBE goals only expenditures to firms that perform a commercially useful function. A firm is considered to perform a commercially useful function when it is responsible for the performance of a clearly defined and distinct element of work and is carrying out its responsibilities by actually performing, managing, and supervising the work involved. To determine whether a firm is performing a commercially useful function, the Chief Procurement Officer shall evaluate the amount of work subcontracted, industry practices, and other relevant factors. The amount of MBE/WBE participation credit shall be based upon an analysis by the Chief Procurement Officer of the specific duties that will be performed by the MBE or WBE. Each MBE/WBE shall be expected to actually perform a substantial (i.e., more than eighty-five percent (85%)) portion of the work contemplated for it by any subcontract or agreement through the use of its own employees and equipment.

Requested information may include, without limitation: (1) specific information concerning brokers’ fees and/or commissions; (2) intended sub-suppliers or other sources of goods and/or services; and (3) specific financial or other risks to be assumed by the MBE/WBE.

C. The participation of MBEs and WBEs who have been certified as “brokers” shall no longer be considered eligible to participate on contracts awarded by the City in 1993 and thereafter until further notice for any consideration of MBE or WBE credit.

D. Credit for the participation of MBEs/WBEs as joint venture partners shall be based upon an analysis of the duties, responsibilities and risks undertaken by the MBE/WBE as specified by the joint venture’s executed joint venture agreement. The Chief Procurement Officer reserves the right to deny or limit MBE/WBE credit to the contractor where any MBE/WBE joint venture partner is found

to have duties, responsibilities, risks or loss and management control over the joint venture that is not commensurate with or in proportion to its joint venture ownership.

4. Regulations Governing Reductions To or Waiver of MBE/WBE Goals

The following Regulations set forth the standards to be used in determining whether or not a reduction or waiver of the MBE/WBE commitment goals of a particular contract is appropriate. If a bidder or proposer determines it is unable to meet the MBE and/or WBE percentage on a City contract, a written request for the reduction or waiver of the commitment must be included in the bid or proposal.

The written request for reduction or waiver from the commitment must be in the form of a signed petition for grant of relief from the MBE/WBE percentages submitted on the bidder/proposer's letterhead, and must demonstrate that all required efforts as set forth in this document were taken to secure eligible Minority and Women Business Enterprises to meet the commitments. The Chief Procurement Officer or designee shall determine whether the request for the reduction or waiver will be granted.

Bidders/proposers will be considered responsive to the terms and conditions of these Regulations if a waiver request and proof of notification to an assist agency is submitted at the time of bid/proposal opening. Once the bids have been opened, the lowest responsive and responsible bidder so deemed by the Chief Procurement Officer or authorized designee will have no more than fourteen (14) calendar days to submit to the Department of Procurement complete documentation that adequately addresses the conditions for waiver described herein. Proposers responding to Request for Proposals (RFPs) who have been identified as a short listed candidate and/or a prospective awardee will be given a designated time allowance, but no more than fourteen (14) calendar days to submit to the Department of Procurement complete documentation that adequately addresses the conditions for waiver described herein. Respondents to Request for Information and or Qualifications (RFI/RFQs) deemed by the Chief Procurement Officer or authorized designee to be the most responsive and responsible shall submit documentation that adequately addresses the conditions for waiver described herein during negotiations. Failure to submit documentation sufficient to support the waiver request will cause the bid/proposal to be found non-responsive by the Chief Procurement Officer, and the bid/proposal will be rejected. In such cases the remedies to be taken by the Chief Procurement Officer, in his discretion, may include, but are not limited to, forfeiture of bid deposit; negotiating with the next lowest bidder/proposer; or re-advertising the bid/proposal. All bidders/proposers are encouraged to submit all required documents at the time of bid opening to expedite the contract award.

A. Direct/Indirect Participation

Each of the following elements must be present in order to determine whether or not such a reduction or waiver is appropriate.

1. The bidder/proposer has documented the unsuccessful solicitation for either subcontractors or joint venture partners of at least 50 % (or at least five when there are more than eleven certified firms in the commodity area) of the appropriate certified MBE/WBE firms to perform any direct or indirect work identified or related to the advertised bid/proposal. Direct participation involves subcontracting a portion

of the goods/services specifically required in the bid/proposal. Indirect participation is the subcontracting of goods/services not specifically related to the performance of this contract. Documentation must include but is not necessarily limited to:

- a. A detailed statement of efforts to identify and select portions of work identified in the bid solicitation for subcontracting to certified MBE/WBE firms;
- b. A listing of all MBE/WBE firms contacted that includes:
 - (1) Names, address and telephone numbers of MBE/WBE firms solicited;
 - (2) Date and time of contact;
 - (3) Method of contact (written, telephone, transmittal of facsimile documents, etc.)
- c. Copies of letters or any other evidence of mailing that substantiates outreach to MBE/WBE vendors that includes:
 - (1) Project identification and location;
 - (2) Classification/commodity of work items for which quotations were sought;
 - (3) Date, item and location for acceptance of subcontractor bid proposals;
 - (4) Detailed statement which summarizes direct negotiations with appropriate MBE/WBE firms for specific portions of the work and indicates why negotiations were unsuccessful;
 - (5) Affirmation that good faith efforts have been demonstrated by choosing subcontracting opportunities likely to achieve MBE/WBE goals by not imposing any limiting conditions which were not mandatory for all subcontractors; or denying the benefits ordinarily conferred on MBE/WBE subcontractors for the type of work that was solicited.

OR

2. Subcontractor participation will be deemed excessively costly when the MBE/WBE subcontractor proposal exceeds the average price quoted by more than twenty percent (20 %). In order to establish that a subcontractor's quote is excessively costly, the bidder/proposer must provide the following information:
 - a. A detailed statement of the work identified for MBE/WBE participation for which the bidder/proposer asserts the MBE/WBE quote(s) were excessively costly (in excess of 20 % higher).
 - (1) A listing of all potential subcontractors contacted for a quotation on that work item;

- (2) Prices quoted for the subcontract in question by all such potential subcontractors for that work item.
- b. Other documentation which demonstrates to the satisfaction of the Chief Procurement Officer that the MBE/WBE proposals are excessively costly, even though not in excess of 20 % higher than the average price quoted. This determination will be based on factors that include, but are not limited to the following:
- (1) The City's estimate for the work under a specific subcontract;
 - (2) The bidder/proposer's own estimate for the work under the subcontract;
 - (3) An average of the bona fide prices quoted for the subcontract;
 - (4) Demonstrated increase in other contract costs as a result of subcontracting to the M/WBE or other firm.

B. Assist Agency Participation

Every waiver and/or reduction request must include evidence that the bidder/proposer has provided timely notice of the need for subcontractors to an appropriate association/assist agency representative of the MBE/WBE business community.

The notice requirement of this Section will be satisfied if a bidder/proposer contacts at least one of the associations on Attachment A to these Regulations when the prime contractor seeks a waiver or reduction in the utilization goals. Attachment B to these Regulations provides the letter format that a prime contractor may use. Proof of notification prior to bid submittal (e.g. certified mail receipt or facsimile transmittal receipt) will be required for any bid/proposal submitted to be deemed responsive on the date of bid opening. If deemed appropriate, the Chief Procurement Officer or Contract Compliance Officer may contact the assist agency for verification of notification.

C. Impracticability

1. If the Chief Procurement Officer determines that a lesser MBE and/or WBE percentage standard is appropriate with respect to a particular contract subject to competitive bidding prior to the bid solicitations for such contract, bid specifications shall include a statement of such revised standard.

2. The requirements set forth in these Regulations shall not apply where the Chief Procurement Officer determines prior to the bid solicitations that MBE/WBE subcontractor participation is impracticable.

This may occur whenever the Chief Procurement Officer determines that for reasons of time, need, industry practices or standards not previously known by the Procurement Department administrator, or such other extreme circumstances as may be deemed appropriate, such a Waiver is in the best interests of the City. This determination may be made in connection with a particular contract,

whether before the contract is let for bid, during the bid or award process, before or during negotiation of the contract, or during the performance of the contract.

For all notifications required to be made by bidders/proposers, in situations where the Chief Procurement Officer has determined that time is of the essence, documented telephone contact may be substituted for letter contact.

5. Procedure to Determine Bid Compliance

The following Schedules and described documents constitute the bidder's MBE/WBE proposal, and must be submitted in accordance with the guidelines stated:

A. **Schedule C-1: Letter of Intent from MBE/WBE to Perform as Subcontractor, Supplier and/or Consultant.**

A Schedule C-1 executed by the MBE/WBE (or Schedule B/Joint Venture Subcontractor) must be submitted by the bidder/proposer for each MBE/WBE included on their Schedule D-1 and must accurately detail the work to be performed by the MBE/WBE and the agreed rates and prices to be paid. If any fully completed and executed Schedule C-1 is not submitted with the bid/proposal, it must be received by the Contract Administrator within ten (10) days of the bid/proposal opening. (All post bid/proposal submissions must have original signatures on all documents): Failure to submit a completed Schedule C-1 in accordance with this section shall entitle the City to deem the bid/proposal non-responsive and therefore reject the bid/proposal.

B. **Letters of Certification.**

A copy of each proposed MBE/WBE firm's current Letter of Certification from the City must be submitted with the bid/proposal. All Letters of Certification issued by the City include a statement of the MBE/WBE firm's Area of Specialty. The MBE/WBE firm's scope of work, as detailed by their Schedule C-1, must conform to their stated Area of Specialty.

C. **Joint Venture Agreements.**

If the bidder's/proposer's MBE/WBE proposal includes the participation of a MBE/WBE as joint venture on any tier (either as the bidder/proposer or as a subcontractor), the bidder/proposer must provide a copy of the joint venture agreement and a Schedule B. In order to demonstrate the MBE/WBE partner's share in the ownership, control, management responsibilities, risks and profits of the joint venture, the proposed joint venture agreement must include specific details related to: (1) contributions of capital and equipment; (2) work responsibilities or other performance to be undertaken by the MBE/WBE; and (3) the commitment of management, supervisory and operative personnel employed by the MBE/WBE to be dedicated to the performance of the contract. The joint venture agreement must also clearly define each partner's authority to contractually obligate the joint venture and each partner's authority to expend joint venture funds (e.g., check signing authority).

D. Required Schedules Regarding DBE/MBE/WBE Utilization.

Bidders must submit, together with the bid, a completed Schedule D-1 committing them to the utilization of each listed MBE/WBE firm. Except in cases where the bidder/proposer has submitted a request for a complete waiver of or variance from the MBE/WBE commitment in accordance with Section IV herein, the bidder/proposer must commit to the expenditure of a specific dollar amount of participation by each MBE/WBE firm included on their Schedule D-1. The total dollar commitment to proposed MBEs must at least equal the MBE goal, and the total dollar commitment to proposed WBEs must at least equal the WBE goal. Bidders are responsible for calculating the dollar equivalent of the MBE and WBE goals as percentages of their total base bids or in the case of Term Agreements, as percentages of the total estimated usage. All commitments made by the bidder's Schedule D-1 must conform to those presented in the submitted Schedule C-1. If Schedule C-1 is submitted after the opening (See Section V.A. above), the bidder/proposer may submit a revised Schedule D-1 (executed and notarized to conform with the Schedules C-1). Except in cases where substantial and documented justification is provided, bidders/proposers will not be allowed to reduce the dollar commitment made to any MBE or WBE in order to achieve conformity between the Schedules C-1 and D-1.

All commitments for joint venture agreements must be delineated in the Schedule B.

6. Reporting Requirements During The Term of The Contract

- A. The contractor shall, not later than thirty (30) days from the award of a contract by the City, execute formal contracts or purchase orders with the MBEs and WBEs included in their approved MBE/WBE Utilization Plan. These written agreements shall be made available to the Chief Procurement Officer upon request.
- B. In the case of one time procurements of supplies with either single or multiple deliveries to be performed in less than one year from the date of contract award, a "MBE/WBE Utilization Report," indicating final MBE and WBE payments shall be submitted directly to the Department of Procurement Services so as to assure receipt either at the same time, or before the using Department receives contractor's final invoice. (NOTICE: Do not submit invoices with "MBE/WBE Utilization Reports.") Final payments may be held until the Utilization Reports have been received.
- C. During the term of all other contracts, the contractor shall submit regular "MBE/WBE Utilization Reports," a copy of which is attached. The frequency with which these reports are to be submitted will be determined by the Chief Procurement Officer, but in no case will reports be required less often than on a quarterly basis. In the absence of written notice from the Chief Procurement Officer, the contractor's first "MBE/WBE Utilization Report" will be due ninety (90) days after the date of contract award, and reports will be due quarterly thereafter.

- D. "MBE/WBE Utilization Reports" are to be submitted directly to: Department of Procurement Services, Division of Contract Monitoring and Compliance, City Hall, Room 400, 121 N. LaSalle Street, Chicago, Illinois 60602.
- E. The Contract Compliance Administrator shall be entitled to examine, on five (5) business days notice, the contractor's books and records including without limitation payroll records, tax returns and records, and books of account, to determine whether the contractor is in compliance with its commitment to MBE/WBE participation and the status of any MBE or WBE performing any portion of the contract. Such rights are in addition to any other audit inspection rights contained in the contract.

7. **MBE/WBE Substitutions**

Changes by the contractor of the commitments earlier certified in the Schedule D-1 are prohibited. In some cases, however, it may become necessary to substitute a new MBE or WBE in order to actually fulfill the MBE/WBE requirements.

The contractor must notify the Chief Procurement Officer immediately in writing of the necessity to reduce or terminate a MBE/WBE subcontract and to utilize a substitute firm for some phase of work. The contractor's notification should include the name, address and principal official of the substitute MBE/WBE and the dollar value and scope of work of the subcontract. Attached should be all the requisite MBE/WBE affidavits and documents, as enumerated above in Section V, "Procedure to Determine Bid Compliance."

The City will not approve extra payment for escalated costs incurred by the contractor when a substitution of subcontractors becomes necessary for the contractor in order to comply with MBE/WBE contract requirements.

After award of contract, no relief of the MBE/WBE requirements will be granted by the City except in exceptional circumstances. Requests for complete or partial waiver of the MBE/WBE requirements of this contract must be made in writing, stating all details of the request, the circumstances, and any additional relevant information. The request must be accompanied by a record of all efforts taken by the contractor to locate specific firms, solicit MBE/WBE bids, seek assistance from technical assistance agencies, etc., as outlined above in the section entitled "Regulations Governing Reductions To or Waiver of MBE/WBE Goals."

8. **Non-Compliance and Damages**

The following constitutes a material breach of this contract and shall entitle the City to declare a default, terminate the contract and exercise those remedies provided for in the contract, at law or in equity:

- A. Failure to satisfy the MBE/WBE percentages required by the contract; and

- B. The contractor or subcontractor is disqualified as a MBE or WBE, such status was a factor in contract award, and was misrepresented by the contractor.

In the event that the contractor is determined not to have been involved in any misrepresentation of the status of the disqualified subcontractor or supplier, the contractor shall seek to discharge the disqualified subcontractor or supplier, upon proper notification to the Chief Procurement Officer and/or Contract Compliance Administrator and make every effort to identify and engage a qualified MBE or WBE as its replacement. Furthermore, continued eligibility to enter into future contracting arrangements with the City may be jeopardized as a result of non-compliance. Payments due to the contractor may be withheld until corrective action is taken.

9. Arbitration

- A. In the event a contractor has not complied with the contractual MBE/WBE percentages in its Schedule D, underutilization of MBEs/WBEs shall entitle the affected MBE/WBE to recover from the contractor damages suffered by such entity as a result of being underutilized; provided, however, that this provision shall not apply to the extent such underutilization occurs pursuant to a waiver or substitution approved by the City. The Ordinance and contracts subject thereto provide that any disputes between the contractor and such affected MBEs/WBEs regarding damages shall be resolved by binding arbitration before an independent arbitrator other than the City, with reasonable expenses, including attorney's fees, being recoverable by a prevailing MBE/WBE in accordance with these regulations. This provision is intended for the benefit of any MBE/WBE affected by underutilization and grants such entity specific third party beneficiary rights. Any rights conferred by this regulation are non-waivable and take precedence over any agreement to the contrary, including but not limited to those contained in a subcontract, suborder, or communicated orally between a contractor and a MBE/WBE.
- B. An MBE/WBE desiring to arbitrate shall contact the contractor in writing to initiate the arbitative process. Except as otherwise agreed to in writing by the affected parties subject to the limitation contained in the last sentence of the previous paragraph, within ten (10) days of the contractor receiving notification of the intent to arbitrate from the MBE/WBE the above-described disputes shall be arbitrated in accordance with the Commercial Arbitration Rules of the American Arbitration Association ("AAA"), a not-for-profit agency, with an office at 225 North Michigan Avenue, Suite 2527, Chicago, Illinois 60601-7601 Phone: (312) 616-6560; Fax: (312) 819-0404. All such arbitrations shall be initiated by the MBE/WBE filing a demand for arbitration with the AAA; shall be conducted by the AAA; and held in Chicago, Illinois.
- C. All fees of the arbitrator are the initial responsibility of the MBE/WBE; provided, however, that the arbitrator is authorized to award reasonable expenses, including attorney's and arbitrator fees, as damages to a prevailing MBE/WBE.
- D. The MBE/WBE must send the City a copy of the "Demand for Arbitration" within ten (10) days after it is filed with the AAA. The MBE/WBE also must send the City a copy of the decision of the

arbitrator within ten (10) days of receiving such decision. Judgment upon the award rendered by the arbitrator may be entered in any court of competent jurisdiction.

10. **Record Keeping**

The Contractor shall maintain records of all relevant data with respect to the utilization of MBEs/WBEs, retaining these records for a period of at least three years after final acceptance of the work. Full access to these records shall be granted to the City, Federal or State authorities in this project, the U.S. Department of Justice, or any duly authorized representatives thereof.

11. **Information Sources**

Small business guaranteed loans; surety bond guarantees; 8 (a) certification:

U.S. Small Business Administration
500 W. Madison Street, Suite 1250
Chicago, Illinois 60661
General Information
(312) 353-4528

S.B.A. - Bond Guarantee Program Surety Bonds
500 West Madison, Suite 1250
Chicago, IL 60661
Attention: Carole Harris
(312) 353-4003

S.B.A. - Procurement Assistance
500 West Madison, Suite 1250
Chicago, Illinois 60661
Attention: Robert P. Murphy, Area Regional Administrator
(312) 353-7381

Project information and general MBE/WBE information:

City of Chicago
Department of Procurement
Contract Monitoring and Compliance
City Hall - Room 403
Chicago, Illinois 60602
Attention: Carnice Carey
(312) 744-1895

City of Chicago
Department of Procurement
Contract Administration Division
City Hall - Room 403
Chicago, Illinois 60602
Attention: Byron Whittaker
(312) 744-4926

Directory of Certified Disadvantaged, Minority and Women Business Enterprises:

City of Chicago
Department of Procurement
Certification Unit
City Hall - Room 403
Chicago, Illinois 60602
Attention: Lillie Cooper
(312) 744-1896

Information on MBE/WBE availability in the manufacturing, sales or supplies, and related fields (direct assistance from 42 regional affiliates located throughout the U.S.):

National Minority Suppliers
Development Council, Inc.
1040 Avenue of the Americas, 2nd Floor
New York, New York 10018
Attention: Harriet R. Michel
(212) 944-2430

Chicago Minority Business
Development Council
11 South LaSalle - Suite 850
Chicago, Illinois 60603
Attention: Maye Foster-Thompson
(312) 263-0105

SCHEDULE C-1

Letter of Intent from MBE/WBE to Prime Firm
as Subcontractor, Supplier and/or Consultant

Name of Project/Contract: _____

Specification Number: _____

From: _____
(Name of MBE/WBE Firm)

MBE: Yes _____ No _____
WBE: Yes _____ No _____

To: _____ and the City of Chicago:
(Name of Prime Contractor - Bidder/Proposer)

The undersigned intends to perform work in connection with the above projects as a:

_____ Sole Proprietor
_____ Partnership

_____ Corporation
_____ Joint Venture

The MBE/WBE status of the undersigned is confirmed by the attached letter of Certification from the City of Chicago effective date of _____ to _____ for a period of one year.

The undersigned is prepared to provide the following described services or supply the following described goods in connection with the above named project/contract:

The above described performance is offered for the following price and described terms of payment:

If more space is needed to fully describe the MBE/WBE firm's proposed scope of work and/or payment schedule, attach additional sheets.

The undersigned will enter into a formal written agreement for the above work with you as a Prime Contractor, conditioned upon your execution of a contract with the City of Chicago, and will do so within (3) three working days of receipt of a signed contract from the City of Chicago.

(Signature of Owner or Authorized Agent)

Name /Title (Print)

Date

Phone

SCHEDULE D-1
Affidavit of MBE/WBE Goal Implementation Plan

Contract Name _____
Specification No. _____

State of _____

County (City) of _____

I HEREBY DECLARE AND AFFIRM that I am duly authorized representative of:

Name of Bidder/Proposer

and that I have personally reviewed the material and facts set forth herein describing our proposed plan to achieve the MBE/WBE goals of this contract.

All MBE/WBE firms included in this plan have been certified as such by the City of Chicago (Letters of Certification Attached).

I. Direct Participation of MBE/WBE Firms

(Note: The bidder/proposer shall, in determining the manner of MBE/WBE participation, first consider involvement with MBE/WBE firms as joint venture partners, subcontractors, and suppliers of goods and services directly related to the performance of this contract.)

A. If bidder/proposer is a certified MBE or WBE firm, attach copy of City of Chicago Letter of Certification. (Certification of the bidder/proposer as a MBE satisfies the MBE goal only. Certification of the bidder/proposer as a WBE satisfies the WBE goal only.)

B. If bidder/proposer is a joint venture and one or more joint venture partners are certified MBEs or WBEs, attach copies of Letters of Certification and a copy of Joint Venture Agreement clearly describing the role of the MBE/WBE firm(s) and its ownership interest in the joint venture.

C. MBE/WBE Subcontractors/Suppliers/Consultants:

1. Name of MBE/WBE: _____
Address: _____
Contact Person: _____ Phone: _____
Dollar Amount Participation \$ _____
Percent Amount of Participation: _____ %
Schedule C-1 attached? Yes _____ No _____ *

*(see next page)

2. Name of MBE/WBE: _____

Address: _____
Contact Person: _____ Phone: _____
Dollar Amount Participation \$ _____
Percent Amount of Participation: _____ %
Schedule C-1 attached? Yes _____ No _____ *

3. Name of MBE/WBE: _____
Address: _____
Contact Person: _____ Phone: _____
Dollar Amount Participation \$ _____
Percent Amount of Participation: _____ %
Schedule C-1 attached? Yes _____ No _____ *

4. Name of MBE/WBE: _____
Address: _____
Contact Person: _____ Phone: _____
Dollar Amount Participation \$ _____
Percent Amount of Participation: _____ %
Schedule C-1 attached? Yes _____ No _____ *

5. Name of MBE/WBE: _____
Address: _____
Contact Person: _____ Phone: _____
Dollar Amount Participation \$ _____
Percent Amount of Participation: _____ %
Schedule C-1 attached? Yes _____ No _____ *

6. Attach additional sheets as needed.

* All Schedule C-1s and Letters of Certification not submitted with bid/proposal must be submitted so as to assure receipt by the Contract Administrator within three (3) business days after bid opening (or proposal due date.)

II. Indirect Participation of MBE/WBE Firms

(Note: This section need not be completed if the MBE/WBE goals have been met through the direct participation outlined in Section I. If the MBE/WBE goals have not been met through direct participation, contractor will be expected to demonstrate that the proposed MBE/WBE direct participation represents the maximum achievable under the circumstances. Only after such a demonstration will indirect participation be considered.)

MBE/WBE Subcontractors/Suppliers/Consultants proposed to perform work or supply goods or services where such performance does not directly relate to the performance of this contract:

A. Name of MBE/WBE: _____
Address: _____
Contact Person: _____ Phone: _____
Dollar Amount Participation \$ _____
Percent Amount of Participation: _____ %
Schedule C-1 attached? Yes _____ No _____ *

B. Name of MBE/WBE: _____
Address: _____
Contact Person: _____ Phone: _____
Dollar Amount Participation \$ _____
Percent Amount of Participation: _____ %
Schedule C-1 attached? Yes _____ No _____ *

C. Name of MBE/WBE: _____
Address: _____
Contact Person: _____ Phone: _____
Dollar Amount Participation \$ _____
Percent Amount of Participation: _____ %
Schedule C-1 attached? Yes _____ No _____ *

D. Name of MBE/WBE: _____
Address: _____
Contact Person: _____ Phone: _____
Dollar Amount Participation \$ _____
Percent Amount of Participation: _____ %
Schedule C-1 attached? Yes _____ No _____ *

E. Attach additional sheets as needed.

* All Schedule C-1s and Letters of Certification not submitted with bid/proposal must be submitted so as to assure receipt by the Contract Administrator within three (3) business days after bid opening (or proposal due date).

III. Summary of MBE/WBE Proposal:

A. MBE Proposal

1. MBE Direct Participation (from Section I.)

MBE Firm Name	Dollar Amount of	Percent Amount of
_____	\$ _____	_____ %
_____	\$ _____	_____ %
_____	\$ _____	_____ %
_____	\$ _____	_____ %
Total Direct MBE Participation	\$ _____	_____ %

2. MBE Indirect Participation (from Section II.)

MBE Firm Name	Dollar Amount of	Percent Amount of
_____	\$ _____	_____ %
_____	\$ _____	_____ %
_____	\$ _____	_____ %
_____	\$ _____	_____ %
Total Indirect MBE Participation	\$ _____	_____ %

B. WBE Proposal

1. WBE Direct Participation (from Section I.)

WBE Firm Name	Dollar Amount of	Percent Amount of
_____	\$ _____	_____ %
_____	\$ _____	_____ %
_____	\$ _____	_____ %
_____	\$ _____	_____ %
Total Direct WBE Participation	\$ _____	_____ %

2. WBE Indirect Participation (from Section II.)

WBE Firm Name	Dollar Amount of	Percent Amount of
_____	\$ _____	_____ %
_____	\$ _____	_____ %
_____	\$ _____	_____ %
_____	\$ _____	_____ %
Total Indirect WBE Participation	\$ _____	_____ %

To the best of my knowledge , information and belief, the facts and representations contained in this Schedule are true, and no material facts have been omitted.

The contractor designates the following person as their MBE/WBE Liaison Officer:

Name _____ Phone Number: _____

I do solemnly declare and affirm under penalties of perjury that the contents of the foregoing document are true and correct, and that I am authorized, on behalf of the contractor, to make this affidavit.

Signature of Affiant (Date)

State of _____

County of _____

This instrument was acknowledged before me on _____ (date)

by _____ (name/s of person/s)

as _____ (type of authority, e.g., officer, trustee, etc.)

of _____ (name of party on behalf of whom instrument was executed).

Signature of Notary Public

(Seal)

EXHIBIT 4

Disclosure Affidavit
(Including Disclosure of Retained Parties)

DISCLOSURE AFFIDAVIT FOR CONTRACTS AND CONCESSION AGREEMENTS NOT INVOLVING FEDERAL FUNDS

Every individual or entity submitting a bid or proposal to the City of Chicago for a contract or concession agreement not involving Federal funds must complete this Disclosure Affidavit (hereafter "Disclosure Affidavit" or "Affidavit"). If the bidder/proposer is a joint venture, the joint venture and each of the joint venture partners must complete a Disclosure Affidavit.

Please print or type all responses clearly and legibly. If you need additional space for a response, attach extra pages. Please indicate the question to which you are responding on any extra pages you attach.

For purposes of this Disclosure Affidavit, the term "Contract" refers to the contract, concession, modification, amendment, extension, or other action in connection with which you are submitting the Disclosure Affidavit.

Please note that this Disclosure Affidavit requires bidders/proposers to obtain various certifications from their subcontractors before the subcontractors may perform any work under the Contract. The terms of the required subcontractor certifications are set forth below in Parts II and IV.

After reviewing your completed Disclosure Affidavit, the Corporation Counsel or the Chief Procurement Officer may require additional information to achieve full disclosure relevant to the bid, proposal or other application.

Project Name: Coordinated Street Furniture Program Bidder/Proposer Name: JCDecaux Chicago, LLC

Purchase Order No.: B91557601 Bidder/Proposer Business Address: 221 North La Salle Street, Suite 1137 Chicago IL 60601

Goods or services to be provided under this Contract: Street Furniture

City Department to which you are submitting this form (check one):

Department of Procurement Services

Other: _____

The undersigned Bernard Parisot as Chief Executive Officer and on behalf of JCDecaux Chicago, LLC ("Bidder/Proposer" or "Contractor"), having been duly sworn under oath certifies as follows:

PART I. DISCLOSURE OF OWNERSHIP INTERESTS

Indicate below whether the bidder/proposer is an individual or a legal entity and, if a legal entity, indicate the type of entity. Then complete Part (A), (B), (C), or (D) below, as applicable. All bidders/proposers must complete Part (E). For bidders/ proposers that are sole proprietorships, Part (E) is the only section of Part I that must be completed.

Individual

Business corporation

Not-for-profit corporation

Sole proprietorship

Limited liability company

Partnership

Joint venture

Other: _____

Disclosure Affidavit

A. CORPORATIONS (FOR-PROFIT AND NOT-FOR-PROFIT)

1. Incorporated in the State of _____

2. List below the name and title of all officers of the corporation:

Name	Title
_____	_____
_____	_____
_____	_____

3. List below the name and title of all directors of the corporation:

Name	Title
_____	_____
_____	_____
_____	_____

TO BE COMPLETED BY FOR-PROFIT CORPORATIONS ONLY:

1. If there are fewer than 100 shareholders, list below the name, business address, and percentage of ownership interest of each shareholder:

Name	Business Address	Ownership Interest
_____	_____	_____ %
_____	_____	_____ %
_____	_____	_____ %

2. If there are 100 or more shareholders, list below the name, business address, and percentage of ownership interest for each shareholder who owns shares equal to or in excess of 7.5% of the proportionate ownership of the corporation:

Name	Business Address	Ownership Interest
_____	_____	_____ %
_____	_____	_____ %
_____	_____	_____ %

TO BE COMPLETED BY NOT-FOR-PROFIT CORPORATIONS ONLY:

List below the name, business address, and percentage of control of each member. If there are no members, write "none".

Name	Business Address	Percentage Control
_____	_____	_____ %
_____	_____	_____ %
_____	_____	_____ %

Disclosure Affidavit

B. PARTNERSHIPS

List below the name and business address of each partner and the percentage of ownership interest of each therein:

Name	Business Address	Ownership Interest
_____	_____	_____ %
_____	_____	_____ %
_____	_____	_____ %

C. LIMITED LIABILITY COMPANIES

1. List below the names and titles of the officers, if any. If there are no officers, write "none".

Name	Title
<u>See Exhibit A</u>	_____
_____	_____
_____	_____

2. List below the name, business address and percentage of ownership interest of each (i) member and (ii) manager:

Name	Business Address	Ownership Interest
<u>JCDecaux North America, Inc.</u>	<u>3 Park Avenue, 33rd Fl.</u>	<u>100%</u>
<u>See Exhibit A</u>	<u>New York, NY 10016</u>	_____ %
_____	_____	_____ %

D. LAND TRUSTS, BUSINESS TRUSTS, ESTATES AND OTHER SIMILAR ENTITIES

1. Trust name and number, or other information identifying the trust: _____

2. List below the name and business address of all trustees:

Name	Business Address
_____	_____
_____	_____
_____	_____

3. List below the name, business address and percentage of ownership interest of all beneficiaries:

Name	Business Address	Ownership Interest
_____	_____	_____ %
_____	_____	_____ %
_____	_____	_____ %

Disclosure Affidavit

E. ADDITIONAL INFORMATION -- TO BE COMPLETED BY ALL BIDDERS/PROPOSERS

1. Is any ownership interest in the bidder/proposer held by one or more agents or nominees on behalf of another individual or legal entity?

Yes No

If so, list below each principal's name, business address, percentage of ownership interest, and the name of the principal's agent or nominee:

Name	Business Address	Ownership Interest	Agent/Nominee
_____	_____	_____%	_____
_____	_____	_____%	_____
_____	_____	_____%	_____

2. Is the bidder/proposer, or any ownership interest in the bidder/proposer, constructively controlled by another individual or legal entity, other than an agent or nominee disclosed above?

Yes No

If so, list below the name and business address of each individual or entity possessing constructive control, the party whose interest is controlled, and the relationship between the two under which the control is or may be exercised:

Name	Business Address	Name of Party Whose Interest is Controlled	Relationship
_____	_____	_____	_____
_____	_____	_____	_____
_____	_____	_____	_____

3. Is any stock or beneficial interest in the bidder/proposer held by a corporation or other legal entity?

Yes No

If so, each such corporation or other legal entity must make all disclosures requested in Part I (Disclosure of Ownership Interests) of this Disclosure Affidavit and must certify all information provided.

NOTE: Pursuant to Section 2-154-020 of the Municipal Code of Chicago, the information provided in Part I must be kept current. In the event of material changes, the bidder/proposer must supplement this Affidavit, up to the time the City takes action on the bid, proposal, or other application for which this Affidavit is being submitted.

PART II. CERTIFICATION REGARDING PROHIBITED CONDUCT

A. CONTRACTOR

1. The Contractor or any subcontractor to be used in the performance of this Contract, or any affiliated entity¹ of the Contractor or any such subcontractor, or any responsible official thereof, or, if acting pursuant to the direction or authorization of a responsible official thereof, any official, agent or employee of the Contractor, any such subcontractor or any such affiliated entity, has not, during a period of three (3) years prior to the date of execution of this Affidavit or, if a subcontractor or subcontractor's affiliated entity, during a period of three (3) years prior to the date of award of the subcontract:

Disclosure Affidavit

- a. Bribe or attempted to bribe, or been convicted of bribery or attempting to bribe, a public officer or employee of the City of Chicago, the State of Illinois, any agency of the Federal government or any State or local government in the United States, in that officer's or employee's official capacity; or
 - b. Agreed or colluded with other bidders or prospective bidders, or been a party to any such agreement or been convicted of agreement or collusion among bidders or prospective bidders, in restraint of freedom of competition by agreement to bid a fixed price or otherwise; or
 - c. Made an admission of guilt of any conduct described in 1(a) and (b) above which is a matter of record but has not been prosecuted for such conduct.
2. Neither the Contractor nor any employee, official, agent, or, for partnerships and joint ventures, partner of the Contractor is barred from contracting with any unit of State or local government as a result of engaging in or being convicted of (a) bid-rigging in violation of 720 ILCS 5/33E-3; (b) bid-rotating in violation of 720 ILCS 5/33E-4; or (c) any similar offense of any State of the United States which contains the same elements as either bid rigging or bid-rotating.
3. The Contractor and its principals, as defined in 49 CFR Sec. 29.105:
- a. Are not currently debarred, suspended, proposed for debarment, declared ineligible, or voluntarily excluded by any Federal, State or local department or agency;
 - b. Have not within a three (3) year period preceding this Affidavit been convicted of a criminal offense in connection with obtaining, attempting to obtain, or performing a public (Federal, State, local) transaction or Contract under a public transaction; a violation of Federal or State antitrust statutes; fraud; embezzlement; theft; forgery; bribery; falsification or destruction of records; making false statements; or receiving stolen property; or had a civil judgment rendered against them for commission of fraud;
 - c. Are not currently indicted for or otherwise criminally or civilly charged by a government entity (Federal, State or local) with commission of any of the offenses enumerated in paragraph (3)(b) above; and
 - d. Have not within a three (3) year period preceding the date of this Affidavit had one or more public transactions (Federal, State or local) terminated for cause or default.
4. If the Contractor is unable to certify to any of the above statements [Part II(A)(1)-(3)], Contractor shall explain below. Attach additional pages if necessary.

_____ [If no explanation appears or begins on the lines above, it shall be conclusively presumed that the Contractor certifies to each of the above statements.]

B. SUBCONTRACTORS

1. The Contractor has obtained certifications in form and substance equal to Part II(A)(1)-(3) of this Affidavit from all subcontractors that the Contractor presently intends to use to perform this Contract. As to subcontractors to be used to perform this Contract who are not yet known by the Contractor, the Contractor will obtain certifications in form and substance equal to Part II(A)(1)-(3) of this Affidavit prior to using them as subcontractors.
2. The Contractor shall not, without the prior written consent of the City, use any subcontractors to perform this Contract if the Contractor, based on information contained in the subcontractor certification or any other information known or obtained by the Contractor, has reason to believe that, within three (3) years prior to the award of any subcontract, the subcontractor or such subcontractor's affiliated entity, or any

Disclosure Affidavit

official, agent, or, employee of such subcontractor or subcontractor's affiliated entity, has engaged in, been convicted of, or made an admission of guilt of any of the conduct listed in Part II(A)(1); or that the subcontractor, an employee, official, agent, or, for partnerships and joint ventures, partner thereof is barred from contracting with any unit of State or local government as a result of engaging in or being convicted of bid-rigging, bid-rotating, or any similar offense; or that any of the circumstances set forth in Part II (A)(3) applies to the subcontractor or its principals. Furthermore, the Contractor shall not, without the prior written consent of the City, use as a subcontractor any individual, firm, partnership, corporation, joint venture or other entity from which the Contractor is unable to obtain a certification in form and substance equal to Part II(A)(1)-(3) of this Affidavit or which the Contractor has reason to believe cannot provide a truthful certification..

3. The Contractor shall maintain all subcontractors' certifications required by Paragraph (1) above for the duration of the Contract and shall make such certifications promptly available to the City upon request.

PART III. CERTIFICATION REGARDING TAXES, FEES AND LITIGATION

A. STATE TAX DELINQUENCIES

Contractor is not delinquent in the payment of any tax administered by the Illinois Department of Revenue or, if delinquent, Contractor is contesting its liability for the tax or the amount of the tax in accordance with the procedures established by the appropriate Revenue Act. Alternatively, Contractor has entered into an agreement with the Illinois Department of Revenue for the payment of all such taxes that are due and is in compliance with such agreement.

B. OTHER TAXES/FEES

Contractor is not delinquent in paying any fine, fee, tax or other charge owed to the City of Chicago.

C. JUDICIAL OR ADMINISTRATIVE PROCEEDINGS

Contractor is not a party to any pending lawsuits against the City nor has Contractor been sued by the City or its agents in any judicial or administrative proceeding within the ten (10) year period preceding execution of this Affidavit.

D. EXCEPTIONS

If the Contractor is unable to certify to any of the above statements [Part III (A)-(C)], Contractor shall explain below. In the case of any judicial or administrative proceedings, provide the (1) case name, (2) docket number; (3) court in which the action is or was pending; and (4) a brief description of each proceeding. Attach additional pages if necessary.

_____ [If no explanation appears or begins on the lines above, it shall be conclusively presumed that the Contractor certifies to each of the above statements.]

PART IV. CERTIFICATION REGARDING ENVIRONMENTAL COMPLIANCE

A. CONTRACTOR

1. Neither the Contractor nor any affiliated entity of the Contractor has, during a period of five (5) years prior to the date of execution of this Affidavit, (a) violated or engaged in any conduct which violated Sections 7-28-440 or 11-4-1500 or Article XIV of Chapter 11-4 or Chapters 7-28 or 11-4 of the Municipal Code or any other Environmental Restriction², (b) received notice of any claim, demand or action, including but not limited to citations and warrants, from the City of Chicago, the State of Illinois, the Federal government, any State or political subdivision thereof, or any agency, court or body of the Federal government or any State or political subdivision thereof, exercising executive, legislative, judicial, regulatory or administrative functions, relating to a violation or alleged violation of Sections 7-28-440 or 11-4-1500 or Article XIV of Chapter 11-4 or Chapters 7-28 or 11-4 of the Municipal Code or any other Environmental Restriction; or

Disclosure Affidavit

twenty percent (20%) interest in the Contractor, and an individual or entity has a fifty percent (50%) interest in Corporation B, then such individual indirectly has a ten percent (10%) interest in the Contractor and the individual is a Substantial Owner of the Contractor. If Corporation B is held by another entity, then this analysis must be applied to that entity.

If Contractor's response below is #1 or #2, then all of the Contractor's Substantial Owners must remain in compliance with any such child support obligations (A) throughout the term of the Contract and any extensions thereof; or (B) until the performance of the Contract is completed, whichever is later. Failure of Contractor's Substantial Owners to remain in compliance with their child support obligations in the manner set forth in either (A) or (B) constitutes an event of default.

Check one:

1. No Substantial Owner has been declared in arrearage on any child support obligations by the Circuit Court of Cook County or by another Illinois court of competent jurisdiction.
2. The Circuit Court of Cook County or another Illinois court of competent jurisdiction has issued an order declaring one or more Substantial Owners in arrearage on their child support obligations. All such Substantial Owners, however, have entered into court-approved agreements for the payment of all such child support owed, and all such Substantial Owners are in compliance with such agreements.
3. The Circuit Court of Cook County or another Illinois court of competent jurisdiction has issued an order declaring one or more Substantial Owners in arrearage on child support obligations and (1) at least one such Substantial Owner has not entered into a court-approved agreement for the payment of all such child support owed; or (2) at least one such Substantial Owner is not in compliance with a court-approved agreement for the payment of all such child support owed; or both (1) and (2).
4. There are no Substantial Owners.

PART VII. AFFIDAVIT OF LOCAL BUSINESS

If this is a competitively bid Contract funded in whole by City funds, Contractor should complete this Section.

- A. Is bidder/proposer a "**Local Business**" as defined by the provisions of this Specification?
[] Yes [] No
- B. How many persons are currently employed by bidder/proposer? _____
- C. Does bidder/proposer have business locations outside the City of Chicago?
[] Yes [] No
If so, list such bidder/proposer's business addresses.
- D. How many of bidder/proposer's current employees work at City of Chicago locations? _____
- E. Is bidder/proposer subject to City of Chicago taxes (including the Head Tax)?
[] Yes [] No

PART VIII. CERTIFICATION REGARDING ELECTED OFFICIALS' BUSINESS RELATIONSHIPS

An ordinance approved by the City Council of the City of Chicago on December 2, 1998, requires that all persons or entities submitting this statement shall indicate whether they had a business relationship with a city elected official in the 12 months prior to the date upon which the statement is signed. A "business relationship" means any contractual or other private business dealing of an official, or his or her spouse, or of any entity in which an official or his or her spouse has a financial interest, with a person or entity which entitles an official to compensation or

Disclosure Affidavit

payment in the amount of \$2,500 or more in a calendar year; provided, however, a financial interest shall not include: (i) any ownership through purchase at fair market value or inheritance of less than one percent of the shares of a corporation, or any corporate subsidiary, parent or affiliate thereof, regardless of the value of or dividends on such share, if such shares are registered on a securities exchange pursuant to the Securities Exchange Act of 1934, as amended; (ii) the authorized compensation paid to an official or employee for his office or employment; (iii) any economic benefit provided equally to all residents of the city; (iv) a time or demand deposit in a financial institution, or (v) an endowment or insurance policy of annuity contract purchased from an insurance company. A "contractual or other private business dealing" shall not include any employment relationship of an official's spouse with an entity when such spouse has no discretion concerning or input relating to the relationship between that entity and the city. **Please indicate below whether the person or entity submitting this statement had a business relationship with a city elected official in the 12 months prior to the date upon which this statement is signed.**

Has the Contractor had a "business relationship" with any City elected official(s) in the 12 months prior to the date of execution of this Disclosure Affidavit?

[] Yes [X] No

If yes, please identify below the name(s) of such City elected official(s) and describe such relationship(s):

PART IX. INCORPORATION INTO CONTRACT, COMPLIANCE AND PENALTIES

The bidder/proposer understands and agrees that:

- A. The above certifications [Parts I-VII] shall become part of any Contract awarded to the bidder/proposer and are a material inducement to the City's execution of the Contract or other action with respect to which this Disclosure Affidavit is being executed and delivered on behalf of the bidder/proposer. Furthermore, the bidder/proposer shall comply with these certifications during the term and/or performance of the Contract or other action.
- B. If the City determines that any information provided herein is false, incomplete or inaccurate, the City may terminate the Contract or other transaction, terminate the applicant's participation in the Contract or other transaction and/or decline to allow the applicant to participate in other Contracts or transactions with the City.
- C. Contractor will terminate its subcontract with any subcontractor, if the City so demands, if the City determines that any information provided by a subcontractor in any of the subcontractor certifications required by this Affidavit is false, incomplete, or inaccurate. Contractor shall insert adequate provisions in all subcontracts to allow it to terminate subcontracts as required by this paragraph.
- D. The following civil and criminal penalties, among others, may apply:
A Contractor who makes a false statement material to Part II(A)(2) of this certification commits a Class 3 Felony. 720 ILCS 5/33E-11(b). Making a false statement concerning Part III(A) of this certification is a Class A misdemeanor, voids the Contract and allows the City to recover all amounts paid to the Contractor under the Contract in a civil action. 65 ILCS 5/11-42.1-1.
- E. This Disclosure Affidavit, some or all of the information provided herein, and any attachments may be made available to the public on the Internet, in response to a Freedom of Information Act request, or otherwise. By completing and signing this Disclosure Affidavit, bidder/proposer waives and releases any possible rights or claims it may have against the City in connection with the public release of any information contained in the completed Disclosure Affidavit and any attachments.

Disclosure Affidavit

PART X. VERIFICATION

Under penalty of perjury, I certify that I am authorized to execute this Disclosure Affidavit on behalf of the Contractor, that I have personal knowledge of all the certifications made herein, and that the same are true.

[Handwritten Signature]

Signature of Authorized Officer

Chief Executive Officer

Title

Bernard Parisot

Name of Authorized Officer (Print or Type)

(646) 834-1200

Business Telephone Number

Subscribed and sworn to before me this *3rd* day

of *June*, 20*07*

[Handwritten Signature]

Notary Public

CINDY SAMUEL
Notary Public, State of New York
No. 01SA6047888
Qualified in New York County
Commission Expires Sept. 18, 2002

Disclosure Affidavit

Notes

1. Business entities are affiliated if, directly or indirectly, one controls or has the power to control the other, or if a third person controls or has the power to control both entities. Indicia of control include without limitation: interlocking management or ownership identity of interests among family members; shared facilities and equipment; common use of employees; or organization of another business entity using substantially the same management, ownership or principals as the first entity.
2. "Environmental Restriction" means any statute, ordinance, rule, regulation, permit, permit condition, order or directive relating to or imposing liability or standards of conduct concerning the release or threatened release of hazardous materials, special wastes or other contaminants into the environment, and to the generation, use, storage, transportation or disposal of construction debris, bulk waste, refuse, garbage, solid wastes, hazardous materials, special wastes or other contaminants, including but not limited to (1) the Comprehensive Environmental Response Compensation and Liability Act (42 U.S.C. § 9601 *et seq.*); (2) the Hazardous Material Transportation Act (49 U.S.C. § 1801 *et seq.*); (3) the Resource Conservation and Recovery Act of 1976 (42 U.S.C. § 6901 *et seq.*); (4) the Clean Water Act (33 U.S.C. § 1251 *et seq.*); (5) the Clean Air Act (42 U.S.C. § 7401 *et seq.*); (6) the Toxic Substances Control Act of 1976 (15 U.S.C. § 2601 *et seq.*); (7) the Safe Drinking Water Act (42 U.S.C. § 300f); (8) the Occupational Health and Safety Act of 1970 (29 U.S.C. § 651 *et seq.*); (9) the Emergency Planning and Community Right to Know Act (42 U.S.C. § 11001 *et seq.*); and (10) the Illinois Environmental Protection Act (415 ILCS 5/1 through 5/56.6).

EXHIBIT A

JCDECAUX CHICAGO, LLC

Board of Managers

Jean-Francois Decaux
Bernard Parisot
Jean-Francois Nion

Ownership Interests

	0%*
	0%
Manager	0%

Officers

Jean-Francois Decaux	President
Bernard Parisot	Chief Executive Officer and Treasurer
Jean-Francois Nion	Chief Operating Officer
Suzanne Davis	Senior Vice President/Secretary
Laurence Raoult	Chief Financial Officer

* Jean-Francois Decaux owns 11.333% interest in JCDecaux Holding S A which owns 69.523% of JCDecaux S A which owns 100% of JCDecaux North America, Inc. which owns 100% of JCDecaux Chicago, LLC.

SUPPLEMENT TO DISCLOSURE AFFIDAVIT

Please fully complete each statement, with all information current as of the date this *Supplement to Disclosure Affidavit* ("SDA") is signed. Every question must be answered.

Please print or type all responses clearly and legibly.

WHO MUST FILE:

Applicants: Any individual or entity (the "Applicant") making an application to the City of Chicago (the "City") for action requiring City Council or other City agency approval must file this SDA. For example, vendors seeking City contracts and individuals or entities applying for concessions, loans or grants are "Applicants."

CERTIFYING THIS SDA: Execute the certification on the date of the initial submission of this SDA. You may be asked to re-certify this SDA on the last page as of the date of submission of any related ordinance to the City Council, or as of the date of the closing of your transaction.

Part I. GENERAL INFORMATION

Date this SDA completed: 06/27/2002

A. Exact legal name of individual or entity submitting this SDA (the "Applicant"):

JC DeCaux Chicago LLC

B. Business address: 221 NORTH LaSalle Street, Chicago, Illinois 60601

C. Telephone: 312 795-3600 Fax: 312 795-3618

D. Name of contact person: NICOLAS CLOCHARD-BOSSUET

E. If a procurement, Specification # B91557601 and Contract # _____; or, if not a procurement, brief description of project: _____

Part II. CERTIFICATION REGARDING INTEREST IN CITY BUSINESS

Any words or terms that are defined in Chapter 2-156 of the Chicago Municipal Code have the same meanings when used in this Part II.

Complete BOTH sections 1 and 2. In accordance with Section 2-156-110 of the Municipal Code of Chicago:

1. Does any official or employee of the City of Chicago have a financial interest in his or her own name or in the name of any other person in this contract, work, business, or transaction?

No.
 Yes.

If yes, identify the officials or employees having such interest and the nature of such interest:

2. Unless sold pursuant to a process of competitive bidding, no official or employee shall have a financial interest in his or her own name or in the name of any other person in the purchase of any property that (i) belongs to the city, or (ii) is sold for taxes or assessments, or (iii) is sold by virtue of legal process at the suit of the city (collectively, "City Property Sale"). Compensation for property taken pursuant to the city's eminent domain power does not constitute a financial interest within the meaning of this section.

If the contract, work, business, or transaction involves a City Property Sale does any official or employee have a financial interest in his or her own name or in the name of any other person in the City Property Sale?

N/A (i.e., the contract, work, business, or transaction is not for a City Property Sale)
 No.
 Yes.

If yes, identify the officials or employees having such interest and the nature of such interest:

3. I further certify that no such financial interest in this contract, work, business, or transaction will be acquired by any official or employee of the City of Chicago.

CONTRACT INCORPORATION, COMPLIANCE, PENALTIES, DISCLOSURE

The Applicant understands and agrees that:

A. The certifications contained in this SDA will become part of any contract awarded to the Applicant by the City in connection with the project or transaction that is the subject of this SDA, whether procurement, City assistance, or other City action, and are material inducements to the City's execution of any contract or taking other action with respect to assisting the project or transaction that is the subject of this SDA. The Applicant understands that it must comply with the certifications contained in this SDA during the term and/or performance of the project or transaction that is the subject of this SDA.

B. If the City determines that any information provided in this SDA is false, incomplete or inaccurate, the City may terminate its contract with the Applicant, terminate any City assistance in connection with the project or transaction that is the subject of this SDA, terminate the Applicant's participation in the project or transaction, and/or decline to allow the Applicant to participate in other transactions with the City.

C. Some or all of the information provided on this SDA and any attachments to this SDA may be made available to the public on the Internet, in response to a Freedom of Information Act request, or otherwise. By completing and signing this SDA, the Applicant waives and releases any possible rights or claims which it may have against the City in connection with the public release of information contained in this SDA and also authorizes the City to verify the accuracy of any information submitted in this SDA.

JCDecaux Chicago LLC
(Print or type name of individual or legal entity submitting this SDA)

By: [Signature]
(sign here)

Title of signatory: Chief Executive Officer

Print or type name of signatory: BERNARD PARISOT

Date: 06/27/2002

(Representative capacity)

County of COOK
State of ILLINOIS
Acknowledged under oath on JUNE 27, 2002
[date] before me by BERNARD PARISOT
as Chief Executive Officer [title]
of JCDecaux Chicago LLC [firm].

Monika Castiglioni
Notary Public
Commission expires: 11-29-02

(Individual)

County of _____
State of _____
Acknowledged under oath on _____
[date] before me by _____

Notary Public
Commission expires: _____

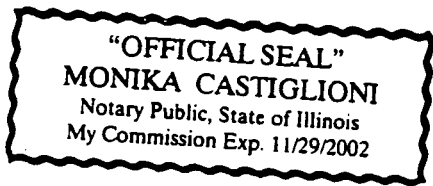

DISCLOSURE AFFIDAVIT FOR CONTRACTS AND CONCESSION AGREEMENTS NOT INVOLVING FEDERAL FUNDS

Every individual or entity submitting a bid or proposal to the City of Chicago for a contract or concession agreement not involving Federal funds must complete this Disclosure Affidavit (hereafter "Disclosure Affidavit" or "Affidavit"). If the bidder/proposer is a joint venture, the joint venture and each of the joint venture partners must complete a Disclosure Affidavit.

Please print or type all responses clearly and legibly. If you need additional space for a response, attach extra pages. Please indicate the question to which you are responding on any extra pages you attach.

For purposes of this Disclosure Affidavit, the term "Contract" refers to the contract, concession, modification, amendment, extension, or other action in connection with which you are submitting the Disclosure Affidavit.

Please note that this Disclosure Affidavit requires bidders/proposers to obtain various certifications from their subcontractors before the subcontractors may perform any work under the Contract. The terms of the required subcontractor certifications are set forth below in Parts II and IV.

After reviewing your completed Disclosure Affidavit, the Corporation Counsel or the Chief Procurement Officer may require additional information to achieve full disclosure relevant to the bid, proposal or other application.

Project Name: Coordinated Street Furniture Program Discloser
 Bidder/Proposer Name: JCDecaux North America, Inc.

Purchase Order No.: B91557601 Bidder/Proposer Business Address:
3 Park Avenue 33rd FL.
New York, NY 10016

Goods or services to be provided under this Contract: Street Furniture

City Department to which you are submitting this form (check one):

- Department of Procurement Services
- Other: _____

The undersigned Bernard Parisot as Co-Chief Executive Officer and on behalf of JCDecaux North America, Inc. ("Bidder/Proposer" or "Contractor"), having been duly sworn under oath certifies as follows: (parent company of JCDecaux Chicago, LLC)

PART I. DISCLOSURE OF OWNERSHIP INTERESTS

Indicate below whether the bidder/proposer is an individual or a legal entity and, if a legal entity, indicate the type of entity. Then complete Part (A), (B), (C), or (D) below, as applicable. All bidders/proposers must complete Part (E). For bidders/ proposers that are sole proprietorships, Part (E) is the only section of Part I that must be completed.

- Individual
- Business corporation
- Not-for-profit corporation
- Sole proprietorship
- Limited liability company
- Partnership
- Joint venture
- Other: _____

Disclosure Affidavit

A. CORPORATIONS (FOR-PROFIT AND NOT-FOR-PROFIT)

1. Incorporated in the State of Delaware

2. List below the name and title of all officers of the corporation:

Name	Title
<u>Bernard Parisot</u>	<u>Co-Chief Executive Officer</u>
<u>Joseph Evans</u>	<u>Co-Chief Executive Officer</u>
<u>Laurence Raoult</u>	<u>Chief Financial Officer</u>

3. List below the name and title of all directors of the corporation:

Name	Title
<u>See Exhibit A</u>	_____
_____	_____
_____	_____

TO BE COMPLETED BY FOR-PROFIT CORPORATIONS ONLY:

1. If there are fewer than 100 shareholders, list below the name, business address, and percentage of ownership interest of each shareholder:

Name	Business Address	Ownership Interest
<u>JCDecaux SA</u>	<u>17 Rue Sayer</u>	<u>100 %</u>
_____	<u>92200 Neuilly Sur Seine</u>	_____ %
_____	<u>France</u>	_____ %

2. If there are 100 or more shareholders, list below the name, business address, and percentage of ownership interest for each shareholder who owns shares equal to or in excess of 7.5% of the proportionate ownership of the corporation:

Name	Business Address	Ownership Interest
_____	_____	_____ %
_____	_____	_____ %
_____	_____	_____ %

TO BE COMPLETED BY NOT-FOR-PROFIT CORPORATIONS ONLY:

List below the name, business address, and percentage of control of each member. If there are no members, write "none".

Name	Business Address	Percentage Control
_____	_____	_____ %
_____	_____	_____ %
_____	_____	_____ %

Disclosure Affidavit

B. PARTNERSHIPS

List below the name and business address of each partner and the percentage of ownership interest of each therein:

Name	Business Address	Ownership Interest
_____	_____	_____ %
_____	_____	_____ %
_____	_____	_____ %

C. LIMITED LIABILITY COMPANIES

1. List below the names and titles of the officers, if any. If there are no officers, write "none".

Name	Title
_____	_____
_____	_____
_____	_____

2. List below the name, business address and percentage of ownership interest of each (i) member and (ii) manager:

Name	Business Address	Ownership Interest
_____	_____	_____ %
_____	_____	_____ %
_____	_____	_____ %

D. LAND TRUSTS, BUSINESS TRUSTS, ESTATES AND OTHER SIMILAR ENTITIES

1. Trust name and number, or other information identifying the trust: _____

2. List below the name and business address of all trustees:

Name	Business Address
_____	_____
_____	_____
_____	_____

3. List below the name, business address and percentage of ownership interest of all beneficiaries:

Name	Business Address	Ownership Interest
_____	_____	_____ %
_____	_____	_____ %
_____	_____	_____ %

Disclosure Affidavit

E. ADDITIONAL INFORMATION -- TO BE COMPLETED BY ALL BIDDERS/PROPOSERS

1. Is any ownership interest in the bidder/proposer held by one or more agents or nominees on behalf of another individual or legal entity?

Yes No

If so, list below each principal's name, business address, percentage of ownership interest, and the name of the principal's agent or nominee:

Name	Business Address	Ownership Interest	Agent/Nominee
_____	_____	_____ %	_____
_____	_____	_____ %	_____
_____	_____	_____ %	_____

2. Is the bidder/proposer, or any ownership interest in the bidder/proposer, constructively controlled by another individual or legal entity, other than an agent or nominee disclosed above?

Yes No

If so, list below the name and business address of each individual or entity possessing constructive control, the party whose interest is controlled, and the relationship between the two under which the control is or may be exercised:

Name	Business Address	Name of Party Whose Interest is Controlled	Relationship
_____	_____	_____	_____
_____	_____	_____	_____
_____	_____	_____	_____

3. Is any stock or beneficial interest in the bidder/proposer held by a corporation or other legal entity?

Yes No

If so, each such corporation or other legal entity must make all disclosures requested in Part I (Disclosure of Ownership Interests) of this Disclosure Affidavit and must certify all information provided.

NOTE: Pursuant to Section 2-154-020 of the Municipal Code of Chicago, the information provided in Part I must be kept current. In the event of material changes, the bidder/proposer must supplement this Affidavit, up to the time the City takes action on the bid, proposal, or other application for which this Affidavit is being submitted.

PART II. CERTIFICATION REGARDING PROHIBITED CONDUCT

A. CONTRACTOR

1. The Contractor or any subcontractor to be used in the performance of this Contract, or any affiliated entity¹ of the Contractor or any such subcontractor, or any responsible official thereof, or, if acting pursuant to the direction or authorization of a responsible official thereof, any official, agent or employee of the Contractor, any such subcontractor or any such affiliated entity, has not, during a period of three (3) years prior to the date of execution of this Affidavit or, if a subcontractor or subcontractor's affiliated entity, during a period of three (3) years prior to the date of award of the subcontract:

Disclosure Affidavit

- a. Bribed or attempted to bribe, or been convicted of bribery or attempting to bribe, a public officer or employee of the City of Chicago, the State of Illinois, any agency of the Federal government or any State or local government in the United States, in that officer's or employee's official capacity; or
 - b. Agreed or colluded with other bidders or prospective bidders, or been a party to any such agreement or been convicted of agreement or collusion among bidders or prospective bidders, in restraint of freedom of competition by agreement to bid a fixed price or otherwise; or
 - c. Made an admission of guilt of any conduct described in 1 (a) and (b) above which is a matter of record but has not been prosecuted for such conduct.
2. Neither the Contractor nor any employee, official, agent, or, for partnerships and joint ventures, partner of the Contractor is barred from contracting with any unit of State or local government as a result of engaging in or being convicted of (a) bid-rigging in violation of 720 ILCS 5/33E-3; (b) bid-rotating in violation of 720 ILCS 5/33E-4; or (c) any similar offense of any State of the United States which contains the same elements as either bid rigging or bid-rotating.
3. The Contractor and its principals, as defined in 49 CFR Sec. 29.105:
- a. Are not currently debarred, suspended, proposed for debarment, declared ineligible, or voluntarily excluded by any Federal, State or local department or agency;
 - b. Have not within a three (3) year period preceding this Affidavit been convicted of a criminal offense in connection with obtaining, attempting to obtain, or performing a public (Federal, State, local) transaction or Contract under a public transaction; a violation of Federal or State antitrust statutes; fraud; embezzlement; theft; forgery; bribery; falsification or destruction of records; making false statements; or receiving stolen property; or had a civil judgment rendered against them for commission of fraud;
 - c. Are not currently indicted for or otherwise criminally or civilly charged by a government entity (Federal, State or local) with commission of any of the offenses enumerated in paragraph (3)(b) above; and
 - d. Have not within a three (3) year period preceding the date of this Affidavit had one or more public transactions (Federal, State or local) terminated for cause or default.
4. If the Contractor is unable to certify to any of the above statements [Part II(A)(1)-(3)], Contractor shall explain below. Attach additional pages if necessary.
-
-
-

_____ [If no explanation appears or begins on the lines above, it shall be conclusively presumed that the Contractor certifies to each of the above statements.]

B. SUBCONTRACTORS

1. The Contractor has obtained certifications in form and substance equal to Part II(A)(1)-(3) of this Affidavit from all subcontractors that the Contractor presently intends to use to perform this Contract. As to subcontractors to be used to perform this Contract who are not yet known by the Contractor, the Contractor will obtain certifications in form and substance equal to Part II(A)(1)-(3) of this Affidavit prior to using them as subcontractors.
2. The Contractor shall not, without the prior written consent of the City, use any subcontractors to perform this Contract if the Contractor, based on information contained in the subcontractor certification or any other information known or obtained by the Contractor, has reason to believe that, within three (3) years prior to the award of any subcontract, the subcontractor or such subcontractor's affiliated entity, or any

Disclosure Affidavit

official, agent, or, employee of such subcontractor or subcontractor's affiliated entity, has engaged in, been convicted of, or made an admission of guilt of any of the conduct listed in Part II(A)(1); or that the subcontractor, an employee, official, agent, or, for partnerships and joint ventures, partner thereof is barred from contracting with any unit of State or local government as a result of engaging in or being convicted of bid-rigging, bid-rotating, or any similar offense; or that any of the circumstances set forth in Part II (A)(3) applies to the subcontractor or its principals. Furthermore, the Contractor shall not, without the prior written consent of the City, use as a subcontractor any individual, firm, partnership, corporation, joint venture or other entity from which the Contractor is unable to obtain a certification in form and substance equal to Part II(A)(1)-(3) of this Affidavit or which the Contractor has reason to believe cannot provide a truthful certification.,

3. The Contractor shall maintain all subcontractors' certifications required by Paragraph (1) above for the duration of the Contract and shall make such certifications promptly available to the City upon request.

PART III. CERTIFICATION REGARDING TAXES, FEES AND LITIGATION

A. STATE TAX DELINQUENCIES

Contractor is not delinquent in the payment of any tax administered by the Illinois Department of Revenue or, if delinquent, Contractor is contesting its liability for the tax or the amount of the tax in accordance with the procedures established by the appropriate Revenue Act. Alternatively, Contractor has entered into an agreement with the Illinois Department of Revenue for the payment of all such taxes that are due and is in compliance with such agreement.

B. OTHER TAXES/FEES

Contractor is not delinquent in paying any fine, fee, tax or other charge owed to the City of Chicago.

C. JUDICIAL OR ADMINISTRATIVE PROCEEDINGS

Contractor is not a party to any pending lawsuits against the City nor has Contractor been sued by the City or its agents in any judicial or administrative proceeding within the ten (10) year period preceding execution of this Affidavit.

D. EXCEPTIONS

If the Contractor is unable to certify to any of the above statements [Part III (A)-(C)], Contractor shall explain below. In the case of any judicial or administrative proceedings, provide the (1) case name, (2) docket number; (3) court in which the action is or was pending; and (4) a brief description of each proceeding. Attach additional pages if necessary.

[If no explanation appears or begins on the lines above, it shall be conclusively presumed that the Contractor certifies to each of the above statements.]

PART IV. CERTIFICATION REGARDING ENVIRONMENTAL COMPLIANCE

A. CONTRACTOR

1. Neither the Contractor nor any affiliated entity of the Contractor has, during a period of five (5) years prior to the date of execution of this Affidavit, (a) violated or engaged in any conduct which violated Sections 7-28-440 or 11-4-1500 or Article XIV of Chapter 11-4 or Chapters 7-28 or 11-4 of the Municipal Code or any other Environmental Restriction², (b) received notice of any claim, demand or action, including but not limited to citations and warrants, from the City of Chicago, the State of Illinois, the Federal government, any State or political subdivision thereof, or any agency, court or body of the Federal government or any State or political subdivision thereof, exercising executive, legislative, judicial, regulatory or administrative functions, relating to a violation or alleged violation of Sections 7-28-440 or 11-4-1500 or Article XIV of Chapter 11-4 or Chapters 7-28 or 11-4 of the Municipal Code or any other Environmental Restriction; or

Disclosure Affidavit

(c) been subject to any fine or penalty of any nature for failure to comply with Sections 7-28-440 or 11-4-1500 or Article XIV of Chapter 11-4 or Chapters 7-28 or 11-4 of the Municipal Code or any other Environmental Restriction.

If the Contractor is unable to certify to any of the above statements [Part IV(A)(1)(a)-(c)], Contractor shall identify all exceptions and indicate whether any such exceptions occurred within the City or otherwise pertain to the City. Attach additional pages if necessary.

[If no explanation appears or begins on the lines above, it shall be conclusively presumed that the Contractor certifies to the above statements.]

2. Contractor shall comply with all requirements of the Clean Air Act ("CAA"), 42 U.S.C. §7401-7642, and the Clean Water Act ("CWA"), 33 U.S.C. §1251-1387, including the requirements of Section 114 of the CAA and Section 308 of the CWA, and all other applicable clean air standards and clean water standards in performing the Contract.
3. Until completion of the Contractor's performance under the Contract, if the Contractor violates Sections 7-28-440 or 11-4-1500, any other provisions of Chapters 7-28 or 11-4 of the Municipal Code, or any other Environmental Restrictions, whether in the performance of the Contract or otherwise, such violation shall be considered an event of default under the Contract.

B. SUBCONTRACTORS

1. The Contractor has obtained certifications in form and substance equal to Part IV(A)(1) and (2) of this Affidavit from all subcontractors that the Contractor presently intends to use to perform this Contract. As to subcontractors to be used to perform this Contract who are not yet known by the Contractor, the Contractor will obtain certifications in form and substance equal to Part IV(A)(1) and (2) of this Affidavit prior to using them as subcontractors.
2. The Contractor shall not, without the prior written consent of the City, use any subcontractors to perform this Contract if the Contractor, based on information contained in the subcontractor certification or any other information known or obtained by Contractor, has reason to believe that the subcontractor has, within the preceding five (5) years, been in violation of any Environmental Restriction, received notice of any claim relating to a violation of an Environmental Restriction, or been subject to any fine or penalty for a violation of an Environmental Restriction. Furthermore, the Contractor shall not, without the prior written consent of the City, use as a subcontractor any individual, firm, partnership, corporation, joint venture or other entity from which the Contractor is unable to obtain a certification in form and substance equal to Part IV(A)(1) and (2) of this Affidavit or which the Contractor has reason to believe cannot provide a truthful certification.
3. The Contractor shall maintain all subcontractors' certifications required by Paragraph (1) above for the duration of the Contract and shall make such certifications promptly available to the City upon request.

PART V. CERTIFICATION REGARDING ETHICS AND INSPECTOR GENERAL

The Contractor understands and will abide by all provisions of Chapter 2-56 of the Municipal Code, entitled "Office of Inspector General", and all provisions of Chapter 2-156 of the Municipal Code, entitled "Governmental Ethics".

PART VI. CERTIFICATION REGARDING COURT-ORDERED CHILD SUPPORT COMPLIANCE

For purposes of this Section VI, "Substantial Owner" means any person who owns or holds a ten percent (10%) or more percentage of interest in the Contractor. If the Contractor is an individual or sole proprietorship, the Substantial Owner is the individual or sole proprietor. Percentage of interest includes direct, indirect and beneficial interests in the Contractor. An indirect or beneficial interest is an interest in the Contractor held either by a corporation, joint venture, trust, partnership, estate or other legal entity in which the individual holds an interest, or by agent(s) or nominee(s) on behalf of an individual or entity. For example, if Corporation B holds or owns a

Disclosure Affidavit

twenty percent (20%) interest in the Contractor, and an individual or entity has a fifty percent (50%) interest in Corporation B, then such individual indirectly has a ten percent (10%) interest in the Contractor and the individual is a Substantial Owner of the Contractor. If Corporation B is held by another entity, then this analysis must be applied to that entity.

If Contractor's response below is #1 or #2, then all of the Contractor's Substantial Owners must remain in compliance with any such child support obligations (A) throughout the term of the Contract and any extensions thereof; or (B) until the performance of the Contract is completed, whichever is later. Failure of Contractor's Substantial Owners to remain in compliance with their child support obligations in the manner set forth in either (A) or (B) constitutes an event of default.

Check one:

1. No Substantial Owner has been declared in arrearage on any child support obligations by the Circuit Court of Cook County or by another Illinois court of competent jurisdiction.
2. The Circuit Court of Cook County or another Illinois court of competent jurisdiction has issued an order declaring one or more Substantial Owners in arrearage on their child support obligations. All such Substantial Owners, however, have entered into court-approved agreements for the payment of all such child support owed, and all such Substantial Owners are in compliance with such agreements.
3. The Circuit Court of Cook County or another Illinois court of competent jurisdiction has issued an order declaring one or more Substantial Owners in arrearage on child support obligations and (1) at least one such Substantial Owner has not entered into a court-approved agreement for the payment of all such child support owed; or (2) at least one such Substantial Owner is not in compliance with a court-approved agreement for the payment of all such child support owed; or both (1) and (2).
4. There are no Substantial Owners.

PART VII. AFFIDAVIT OF LOCAL BUSINESS

If this is a competitively bid Contract funded in whole by City funds, Contractor should complete this Section.

- A. Is bidder/proposer a "Local Business" as defined by the provisions of this Specification?
[] Yes [] No
- B. How many persons are currently employed by bidder/proposer? _____
- C. Does bidder/proposer have business locations outside the City of Chicago?
[] Yes [] No
If so, list such bidder/proposer's business addresses.
- D. How many of bidder/proposer's current employees work at City of Chicago locations? _____
- E. Is bidder/proposer subject to City of Chicago taxes (including the Head Tax)?
[] Yes [] No

PART VIII. CERTIFICATION REGARDING ELECTED OFFICIALS' BUSINESS RELATIONSHIPS

An ordinance approved by the City Council of the City of Chicago on December 2, 1998, requires that all persons or entities submitting this statement shall indicate whether they had a business relationship with a city elected official in the 12 months prior to the date upon which the statement is signed. A "business relationship" means any contractual or other private business dealing of an official, or his or her spouse, or of any entity in which an official or his or her spouse has a financial interest, with a person or entity which entitles an official to compensation or

Disclosure Affidavit

payment in the amount of \$2,500 or more in a calendar year; provided, however, a financial interest shall not include: (i) any ownership through purchase at fair market value or inheritance of less than one percent of the shares of a corporation, or any corporate subsidiary, parent or affiliate thereof, regardless of the value of or dividends on such share, if such shares are registered on a securities exchange pursuant to the Securities Exchange Act of 1934, as amended; (ii) the authorized compensation paid to an official or employee for his office or employment; (iii) any economic benefit provided equally to all residents of the city; (iv) a time or demand deposit in a financial institution, or (v) an endowment or insurance policy of annuity contract purchased from an insurance company. A "contractual or other private business dealing" shall not include any employment relationship of an official's spouse with an entity when such spouse has no discretion concerning or input relating to the relationship between that entity and the city. **Please indicate below whether the person or entity submitting this statement had a business relationship with a city elected official in the 12 months prior to the date upon which this statement is signed.**

Has the Contractor had a "business relationship" with any City elected official(s) in the 12 months prior to the date of execution of this Disclosure Affidavit?

Yes No

If yes, please identify below the name(s) of such City elected official(s) and describe such relationship(s):

PART IX. INCORPORATION INTO CONTRACT, COMPLIANCE AND PENALTIES

The bidder/proposer understands and agrees that:

- A. The above certifications [Parts I-VII] shall become part of any Contract awarded to the bidder/proposer and are a material inducement to the City's execution of the Contract or other action with respect to which this Disclosure Affidavit is being executed and delivered on behalf of the bidder/proposer. Furthermore, the bidder/proposer shall comply with these certifications during the term and/or performance of the Contract or other action.
- B. If the City determines that any information provided herein is false, incomplete or inaccurate, the City may terminate the Contract or other transaction, terminate the applicant's participation in the Contract or other transaction and/or decline to allow the applicant to participate in other Contracts or transactions with the City.
- C. Contractor will terminate its subcontract with any subcontractor, if the City so demands, if the City determines that any information provided by a subcontractor in any of the subcontractor certifications required by this Affidavit is false, incomplete, or inaccurate. Contractor shall insert adequate provisions in all subcontracts to allow it to terminate subcontracts as required by this paragraph.
- D. The following civil and criminal penalties, among others, may apply:

A Contractor who makes a false statement material to Part II(A)(2) of this certification commits a Class 3 Felony. 720 ILCS 5/33E-11(b). Making a false statement concerning Part III(A) of this certification is a Class A misdemeanor, voids the Contract and allows the City to recover all amounts paid to the Contractor under the Contract in a civil action. 65 ILCS 5/11-42.1-1.
- E. This Disclosure Affidavit, some or all of the information provided herein, and any attachments may be made available to the public on the Internet, in response to a Freedom of Information Act request, or otherwise. By completing and signing this Disclosure Affidavit, bidder/proposer waives and releases any possible rights or claims it may have against the City in connection with the public release of any information contained in the completed Disclosure Affidavit and any attachments.

Disclosure Affidavit

PART X VERIFICATION

Under penalty of perjury, I certify that I am authorized to execute this Disclosure Affidavit on behalf of the Contractor, that I have personal knowledge of all the certifications made herein, and that the same are true.

B. Parisot

Signature of Authorized Officer

Bernard Parisot

Name of Authorized Officer (Print or Type)

Co-Chief Executive Officer

Title

(646) 834-1200

Business Telephone Number

Subscribed and sworn to before me this 3rd day

of June, 2002

[Signature]

Notary Public

CINDY SAMUEL
Notary Public, State of New York
No. 01SA6047888
Qualified in New York County
Commission Expires Sept. 18, 2002

Disclosure Affidavit

Notes

1. Business entities are affiliated if, directly or indirectly, one controls or has the power to control the other, or if a third person controls or has the power to control both entities. Indicia of control include without limitation: interlocking management or ownership identity of interests among family members; shared facilities and equipment; common use of employees; or organization of another business entity using substantially the same management, ownership or principals as the first entity.
2. "Environmental Restriction" means any statute, ordinance, rule, regulation, permit, permit condition, order or directive relating to or imposing liability or standards of conduct concerning the release or threatened release of hazardous materials, special wastes or other contaminants into the environment, and to the generation, use, storage, transportation or disposal of construction debris, bulk waste, refuse, garbage, solid wastes, hazardous materials, special wastes or other contaminants, including but not limited to (1) the Comprehensive Environmental Response Compensation and Liability Act (42 U.S.C. § 9601 *et seq.*); (2) the Hazardous Material Transportation Act (49 U.S.C. § 1801 *et seq.*); (3) the Resource Conservation and Recovery Act of 1976 (42 U.S.C. § 6901 *et seq.*); (4) the Clean Water Act (33 U.S.C. § 1251 *et seq.*); (5) the Clean Air Act (42 U.S.C. § 7401 *et seq.*); (6) the Toxic Substances Control Act of 1976 (15 U.S.C. § 2601 *et seq.*); (7) the Safe Drinking Water Act (42 U.S.C. § 300f); (8) the Occupational Health and Safety Act of 1970 (29 U.S.C. § 651 *et seq.*); (9) the Emergency Planning and Community Right to Know Act (42 U.S.C. § 11001 *et seq.*); and (10) the Illinois Environmental Protection Act (415 ILCS 5/1 through 5/56.6).

EXHIBIT A

Board of Directors of JCDecaux North America, Inc.

Jean-Francois Decaux (Chair)
Joseph Evans
Bernard Parisot
Laurence Raoult

DISCLOSURE AFFIDAVIT FOR CONTRACTS AND CONCESSION AGREEMENTS NOT INVOLVING FEDERAL FUNDS

Every individual or entity submitting a bid or proposal to the City of Chicago for a contract or concession agreement not involving federal funds must complete this Disclosure Affidavit (hereafter "Disclosure Affidavit" or "Affidavit"). If the bidder/proposer is a joint venture, the joint venture and each of the joint venture partners must complete a Disclosure Affidavit.

Please print or type all responses clearly and legibly. If you need additional space for a response, attach extra pages. Please indicate the question to which you are responding on any extra pages you attach.

For purposes of this Disclosure Affidavit, the term "Contract" refers to the contract, concession, modification, amendment, extension, or other action in connection with which you are submitting the Disclosure Affidavit.

Please note that this Disclosure Affidavit requires bidders/proposers to obtain various certifications from their subcontractors before the subcontractors may perform any work under the Contract. The terms of the required subcontractor certifications are set forth below in Parts II and IV.

After reviewing your completed Disclosure Affidavit, the Corporation Counsel or the Purchasing Agent may require additional information to achieve full disclosure relevant to the bid, proposal, or other application.

Project Name: COORDINATED STREET FURNITURE Program

Discloser Bidder/Proposer Name: JC Decaux SA

Purchase Order No.: B 91557601

Bidder/Proposer Business Address: 17 RUE SOYER
92200 Neuilly Sur Seine France

Goods or services to be provided under this Contract: STREET FURNITURE

City department to which you are submitting this form (check one):

Purchasing

Other: _____

The undersigned, Jean-Francois Decaux as Chief Executive Officer and on behalf of JC Decaux SA, parent company of JC Decaux NORTH AMERICA, INC. ("Bidder/Proposer" or "Contractor"), having been duly sworn under oath certifies as follows:

PART I. DISCLOSURE OF OWNERSHIP INTERESTS

Indicate below whether the bidder/proposer is an individual or a legal entity and, if a legal entity, indicate the type of entity. Then complete Part (A), (B), (C), or (D) below, as applicable. All bidders/proposers must complete Part (E). For bidders/proposers that are sole proprietorships, Part (E) is the only section of Part I that must be completed.

- | | |
|-----------------------------------------------------|-------------------------------------------------------------------|
| <input type="checkbox"/> Individual | <input type="checkbox"/> Limited liability company |
| <input type="checkbox"/> Business corporation | <input type="checkbox"/> Partnership |
| <input type="checkbox"/> Not-for-profit corporation | <input type="checkbox"/> Joint venture |
| <input type="checkbox"/> Sole proprietorship | <input checked="" type="checkbox"/> Other: <u>Société anonyme</u> |

Disclosure Affidavit

A. CORPORATIONS (FOR-PROFIT AND NOT-FOR-PROFIT)

French Société Anonyme
(Similar to a corporation)

- Incorporated in the State of _____
- List below the name and title of all officers of the corporation:

Name	Title
_____ See Exhibit A	_____
_____	_____
_____	_____

- List below the name and title of all directors of the corporation:

Name	Title
_____ See Exhibit A	_____
_____	_____
_____	_____

TO BE COMPLETED BY FOR-PROFIT CORPORATIONS ONLY:

- If there are fewer than 100 shareholders, list below the name, business address, and percentage of ownership interest of each shareholder:

Name	Business Address	Ownership Interest
_____	_____	_____ %
_____	_____	_____ %
_____	_____	_____ %

- If there are 100 or more shareholders, list below the name, business address, and percentage of ownership interest for each shareholder who owns shares equal to or in excess of 7.5% of the proportionate ownership of the corporation:

Name	Business Address	Ownership Interest
_____ See Exhibit A	_____	_____ %
_____	_____	_____ %
_____	_____	_____ %

TO BE COMPLETED BY NOT-FOR-PROFIT CORPORATIONS ONLY:

List below the name, business address, and percentage of control of each member. If there are no members, write "none".

Name	Business Address	Percentage Control
_____	_____	_____ %
_____	_____	_____ %
_____	_____	_____ %

Disclosure Affidavit

B. PARTNERSHIPS

List below the name and business address of each partner and the percentage of ownership interest of each therein:

Name	Business Address	Ownership Interest
_____	_____	_____ %
_____	_____	_____ %
_____	_____	_____ %

C. LIMITED LIABILITY COMPANIES

1. List below the names and titles of the officers, if any. If there are no officers, write "none".

Name	Title
_____	_____
_____	_____
_____	_____

2. List below the name, business address and percentage of ownership interest of each (i) member and (ii) manager:

Name	Business Address	Ownership Interest
_____	_____	_____ %
_____	_____	_____ %
_____	_____	_____ %

D. LAND TRUSTS, BUSINESS TRUSTS, ESTATES AND OTHER SIMILAR ENTITIES

1. Trust name and number, or other information identifying the trust: _____

2. List below the name and business address of all trustees:

Name	Business Address
_____	_____
_____	_____
_____	_____

3. List below the name, business address and percentage of ownership interest of all beneficiaries:

Name	Business Address	Ownership Interest
_____	_____	_____ %
_____	_____	_____ %
_____	_____	_____ %

Disclosure Affidavit

E. ADDITIONAL INFORMATION -- TO BE COMPLETED BY ALL BIDDERS/PROPOSERS

1. Is any ownership interest in the bidder/proposer held by one or more agents or nominees on behalf of another individual or legal entity?

[] Yes [X] No

If so, list below each principal's name, business address, percentage of ownership interest, and the name of the principal's agent or nominee:

Name	Business Address	Ownership Interest	Agent/Nominee
_____	_____	_____%	_____
_____	_____	_____%	_____
_____	_____	_____%	_____

2. Is the bidder/proposer, or any ownership interest in the bidder/proposer, constructively controlled by another individual or legal entity, other than an agent or nominee disclosed above?

[] Yes [X] No

If so, list below the name and business address of each individual or entity possessing constructive control, the party whose interest is controlled, and the relationship between the two under which the control is or may be exercised:

Name	Business Address	Name of Party Whose Interest is Controlled	Relationship
_____	_____	_____	_____
_____	_____	_____	_____
_____	_____	_____	_____

3. Is any stock or beneficial interest in the bidder/proposer held by a corporation or other legal entity?

[X] Yes [] No

If so, each such corporation or other legal entity must make all disclosures requested in Part I (Disclosure of Ownership Interests) of this Disclosure Affidavit and must certify all information provided.

NOTE: Pursuant to Section 2-154-020 of the Municipal Code of Chicago, the information provided in Part I must be kept current. In the event of material changes, the bidder/proposer must supplement this Affidavit, up to the time the City takes action on the bid, proposal, or other application for which this Affidavit is being submitted.

PART II. CERTIFICATION REGARDING PROHIBITED CONDUCT

A. CONTRACTOR

1. The Contractor or any subcontractor to be used in the performance of this Contract, or any affiliated entity¹ of the Contractor or any such subcontractor, or any responsible official thereof, or, if acting pursuant to the direction or authorization of a responsible official thereof, any official, agent or employee of the Contractor, any such subcontractor or any such affiliated entity, has not, during a period of three (3) years prior to the date of execution of this Affidavit or, if a subcontractor or subcontractor's affiliated entity, during a period of three (3) years prior to the date of award of the subcontract:

Disclosure Affidavit

- a. Bribe or attempted bribe, or been convicted of bribery or attempting to bribe, a public officer or employee of the City of Chicago, the State of Illinois, any agency of the Federal government or any State or local government in the United States, in that officer's or employee's official capacity; or
 - b. Agreed or colluded with other bidders or prospective bidders, or been a party to any such agreement or been convicted of agreement or collusion among bidders or prospective bidders, in restraint of freedom of competition by agreement to bid a fixed price or otherwise; or
 - c. Made an admission of guilt of any conduct described in 1 (a) and (b) above which is a matter of record but has not been prosecuted for such conduct.
2. Neither the Contractor nor any employee, official, agent, or, for partnerships and joint ventures, partner of the Contractor is barred from contracting with any unit of State or local government as a result of engaging in or being convicted of (a) bid-rigging in violation of 720 ILCS 5/33E-3; (b) bid-rotating in violation of 720 ILCS 5/33E-4; or (c) any similar offense of any State of the United States which contains the same elements as either bid rigging or bid-rotating.
3. The Contractor and its principals, as defined in 49 CFR Sec. 29.105:
- a. Are not currently debarred, suspended, proposed for debarment, declared ineligible, or voluntarily excluded by any Federal, State or local department or agency;
 - b. Have not within a three (3) year period preceding this Affidavit been convicted of a criminal offense in connection with obtaining, attempting to obtain, or performing a public (Federal, State, local) transaction or Contract under a public transaction; a violation of Federal or State antitrust statutes; fraud; embezzlement; theft; forgery; bribery; falsification or destruction of records; making false statements; or receiving stolen property; or had a civil judgment rendered against them for commission of fraud;
 - c. Are not currently indicted for or otherwise criminally or civilly charged by a government entity (Federal, State or local) with commission of any of the offenses enumerated in paragraph (3)(b) above; and
 - d. Have not within a three (3) year period preceding the date of this Affidavit had one or more public transactions (Federal, State or local) terminated for cause or default.
4. If the Contractor is unable to certify to any of the above statements [Part II(A)(1)-(3)], Contractor shall explain below. Attach additional pages if necessary. _____

_____ [If no explanation appears or begins on the lines above, it shall be conclusively presumed that the Contractor certifies to each of the above statements.]

B. SUBCONTRACTORS

1. The Contractor has obtained certifications in form and substance equal to Part II(A)(1)-(3) of this Affidavit from all subcontractors that the Contractor presently intends to use to perform this Contract. As to subcontractors to be used to perform this Contract who are not yet known by the Contractor, the Contractor will obtain certifications in form and substance equal to Part II(A)(1)-(3) of this Affidavit prior to using them as subcontractors.
2. The Contractor shall not, without the prior written consent of the City, use any subcontractors to perform this Contract if the Contractor, based on information contained in the subcontractor certification or any other information known or obtained by the Contractor, has reason to believe that, within three (3) years prior to the award of any subcontract, the subcontractor or such subcontractor's affiliated entity, or any

Disclosure Affidavit

official, agent, or, employee of such subcontractor or subcontractor's affiliated entity, has engaged in, been convicted of, or made an admission of guilt of any of the conduct listed in Part II(A)(1); or that the subcontractor, an employee, official, agent, or, for partnerships and joint ventures, partner thereof is barred from contracting with any unit of State or local government as a result of engaging in or being convicted of bid-rigging, bid-rotating, or any similar offense; or that any of the circumstances set forth in Part II (A)(3) applies to the subcontractor or its principals. Furthermore, the Contractor shall not, without the prior written consent of the City, use as a subcontractor any individual, firm, partnership, corporation, joint venture or other entity from which the Contractor is unable to obtain a certification in form and substance equal to Part II(A)(1)-(3) of this Affidavit or which the Contractor has reason to believe cannot provide a truthful certification.,

3. The Contractor shall maintain all subcontractors' certifications required by Paragraph (1) above for the duration of the Contract and shall make such certifications promptly available to the City upon request.

PART III. CERTIFICATION REGARDING TAXES, FEES AND LITIGATION

A. STATE TAX DELINQUENCIES

Contractor is not delinquent in the payment of any tax administered by the Illinois Department of Revenue or, if delinquent, Contractor is contesting its liability for the tax or the amount of the tax in accordance with the procedures established by the appropriate Revenue Act. Alternatively, Contractor has entered into an agreement with the Illinois Department of Revenue for the payment of all such taxes that are due and is in compliance with such agreement.

B. OTHER TAXES/FEES

Contractor is not delinquent in paying any fine, fee, tax or other charge owed to the City of Chicago.

C. JUDICIAL OR ADMINISTRATIVE PROCEEDINGS

Contractor is not a party to any pending lawsuits against the City nor has Contractor been sued by the City or its agents in any judicial or administrative proceeding within the ten (10) year period preceding execution of this Affidavit.

D. EXCEPTIONS

If the Contractor is unable to certify to any of the above statements [Part III (A)-(C)], Contractor shall explain below. In the case of any judicial or administrative proceedings, provide the (1) case name, (2) docket number; (3) court in which the action is or was pending; and (4) a brief description of each proceeding. Attach additional pages if necessary.

[If no explanation appears or begins on the lines above, it shall be conclusively presumed that the Contractor certifies to each of the above statements.]

PART IV. CERTIFICATION REGARDING ENVIRONMENTAL COMPLIANCE

A. CONTRACTOR

1. Neither the Contractor nor any affiliated entity of the Contractor has, during a period of five (5) years prior to the date of execution of this Affidavit, (a) violated or engaged in any conduct which violated Sections 7-28-440 or 11-4-1500 or Article XIV of Chapter 11-4 or Chapters 7-28 or 11-4 of the Municipal Code or any other Environmental Restriction², (b) received notice of any claim, demand or action, including but not limited to citations and warrants, from the City of Chicago, the State of Illinois, the Federal government, any State or political subdivision thereof, or any agency, court or body of the Federal government or any State or political subdivision thereof, exercising executive, legislative, judicial, regulatory or administrative functions, relating to a violation or alleged violation of Sections 7-28-440 or 11-4-1500 or Article XIV of Chapter 11-4 or Chapters 7-28 or 11-4 of the Municipal Code or any other Environmental Restriction; or

Disclosure Affidavit

(c) been subject to any fine or penalty of any nature for failure to comply with Sections 7-28-440 or 11-4-1500 or Article XIV of Chapter 11-4 or Chapters 7-28 or 11-4 of the Municipal Code or any other Environmental Restriction.

If the Contractor is unable to certify to any of the above statements [Part IV(A)(1)(a)-(c)], Contractor shall identify all exceptions and indicate whether any such exceptions occurred within the City or otherwise pertain to the City. Attach additional pages if necessary.

_____ [If no explanation appears or begins on the lines above, it shall be conclusively presumed that the Contractor certifies to the above statements.]

2. Contractor shall comply with all requirements of the Clean Air Act ("CAA"), 42 U.S.C. §7401-7642, and the Clean Water Act ("CWA"), 33 U.S.C. §1251-1387, including the requirements of Section 114 of the CAA and Section 308 of the CWA, and all other applicable clean air standards and clean water standards in performing the Contract.
3. Until completion of the Contractor's performance under the Contract, if the Contractor violates Sections 7-28-440 or 11-4-1500, any other provisions of Chapters 7-28 or 11-4 of the Municipal Code, or any other Environmental Restrictions, whether in the performance of the Contract or otherwise, such violation shall be considered an event of default under the Contract.

B. SUBCONTRACTORS

1. The Contractor has obtained certifications in form and substance equal to Part IV(A)(1) and (2) of this Affidavit from all subcontractors that the Contractor presently intends to use to perform this Contract. As to subcontractors to be used to perform this Contract who are not yet known by the Contractor, the Contractor will obtain certifications in form and substance equal to Part IV(A)(1) and (2) of this Affidavit prior to using them as subcontractors.
2. The Contractor shall not, without the prior written consent of the City, use any subcontractors to perform this Contract if the Contractor, based on information contained in the subcontractor certification or any other information known or obtained by Contractor, has reason to believe that the subcontractor has, within the preceding five (5) years, been in violation of any Environmental Restriction, received notice of any claim relating to a violation of an Environmental Restriction, or been subject to any fine or penalty for a violation of an Environmental Restriction. Furthermore, the Contractor shall not, without the prior written consent of the City, use as a subcontractor any individual, firm, partnership, corporation, joint venture or other entity from which the Contractor is unable to obtain a certification in form and substance equal to Part IV(A)(1) and (2) of this Affidavit or which the Contractor has reason to believe cannot provide a truthful certification.
3. The Contractor shall maintain all subcontractors' certifications required by Paragraph (1) above for the duration of the Contract and shall make such certifications promptly available to the City upon request.

PART V. CERTIFICATION REGARDING ETHICS AND INSPECTOR GENERAL

The Contractor understands and will abide by all provisions of Chapter 2-56 of the Municipal Code, entitled "Office of Inspector General", and all provisions of Chapter 2-156 of the Municipal Code, entitled "Governmental Ethics".

PART VI. CERTIFICATION REGARDING COURT-ORDERED CHILD SUPPORT COMPLIANCE

For purposes of this Section VI, "Substantial Owner" means any person who owns or holds a ten percent (10%) or more percentage of interest in the Contractor. If the Contractor is an individual or sole proprietorship, the Substantial Owner is the individual or sole proprietor. Percentage of interest includes direct, indirect and beneficial interests in the Contractor. An indirect or beneficial interest is an interest in the Contractor held either by a corporation, joint venture, trust, partnership, estate or other legal entity in which the individual holds an interest, or by agent(s) or nominee(s) on behalf of an individual or entity. For example, if Corporation B holds or owns a

Disclosure Affidavit

twenty percent (20%) interest in the Contractor, and an individual or entity has a fifty percent (50%) interest in Corporation B, then such individual indirectly has a ten percent (10%) interest in the Contractor and the individual is a Substantial Owner of the Contractor. If Corporation B is held by another entity, then this analysis must be applied to that entity.

If Contractor's response below is #1 or #2, then all of the Contractor's Substantial Owners must remain in compliance with any such child support obligations (A) throughout the term of the Contract and any extensions thereof; or (B) until the performance of the Contract is completed, whichever is later. Failure of Contractor's Substantial Owners to remain in compliance with their child support obligations in the manner set forth in either (A) or (B) constitutes an event of default.

Check one:

1. No Substantial Owner has been declared in arrearage on any child support obligations by the Circuit Court of Cook County or by another Illinois court of competent jurisdiction.
2. The Circuit Court of Cook County or another Illinois court of competent jurisdiction has issued an order declaring one or more Substantial Owners in arrearage on their child support obligations. All such Substantial Owners, however, have entered into court-approved agreements for the payment of all such child support owed, and all such Substantial Owners are in compliance with such agreements.
3. The Circuit Court of Cook County or another Illinois court of competent jurisdiction has issued an order declaring one or more Substantial Owners in arrearage on child support obligations and (1) at least one such Substantial Owner has not entered into a court-approved agreement for the payment of all such child support owed; or (2) at least one such Substantial Owner is not in compliance with a court-approved agreement for the payment of all such child support owed; or both (1) and (2).
4. There are no Substantial Owners.

PART VII. AFFIDAVIT OF LOCAL BUSINESS

If this is a competitively bid Contract funded in whole by City funds, Contractor should complete this Section.

- A. Is bidder/proposer a "Local Business" as defined by the provisions of this Specification?
[] Yes [] No
- B. How many persons are currently employed by bidder/proposer? _____
- C. Does bidder/proposer have business locations outside the City of Chicago?
[] Yes [] No
If so, list such bidder/proposer's business addresses.
- D. How many of bidder/proposer's current employees work at City of Chicago locations? _____
- E. Is bidder/proposer subject to City of Chicago taxes (including the Head Tax)?
[] Yes [] No

PART VIII. CERTIFICATION REGARDING ELECTED OFFICIALS' BUSINESS RELATIONSHIPS

An ordinance approved by the City Council of the City of Chicago on December 2, 1998, requires that all persons or entities submitting this statement shall indicate whether they had a business relationship with a city elected official in the 12 months prior to the date upon which the statement is signed. A "business relationship" means any contractual or other private business dealing of an official, or his or her spouse, or of any entity in which an official or his or her spouse has a financial interest, with a person or entity which entitles an official to compensation or

Disclosure Affidavit

payment in the amount of \$2,500 or more in a calendar year; provided, however, a financial interest shall not include: (i) any ownership through purchase at fair market value or inheritance of less than one percent of the shares of a corporation, or any corporate subsidiary, parent or affiliate thereof, regardless of the value of or dividends on such share, if such shares are registered on a securities exchange pursuant to the Securities Exchange Act of 1934, as amended; (ii) the authorized compensation paid to an official or employee for his office or employment; (iii) any economic benefit provided equally to all residents of the city; (iv) a time or demand deposit in a financial institution, or (v) an endowment or insurance policy of annuity contract purchased from an insurance company. A "contractual or other private business dealing" shall not include any employment relationship of an official's spouse with an entity when such spouse has no discretion concerning or input relating to the relationship between that entity and the city. **Please indicate below whether the person or entity submitting this statement had a business relationship with a city elected official in the 12 months prior to the date upon which this statement is signed.**

Has the Contractor had a "business relationship" with any City elected official(s) in the 12 months prior to the date of execution of this Disclosure Affidavit?

Yes No

If yes, please identify below the name(s) of such City elected official(s) and describe such relationship(s):

PART IX. INCORPORATION INTO CONTRACT, COMPLIANCE AND PENALTIES

The bidder/proposer understands and agrees that:

- A. The above certifications [Parts I-VII] shall become part of any Contract awarded to the bidder/proposer and are a material inducement to the City's execution of the Contract or other action with respect to which this Disclosure Affidavit is being executed and delivered on behalf of the bidder/proposer. Furthermore, the bidder/proposer shall comply with these certifications during the term and/or performance of the Contract or other action.
- B. If the City determines that any information provided herein is false, incomplete or inaccurate, the City may terminate the Contract or other transaction, terminate the applicant's participation in the Contract or other transaction and/or decline to allow the applicant to participate in other Contracts or transactions with the City.
- C. Contractor will terminate its subcontract with any subcontractor, if the City so demands, if the City determines that any information provided by a subcontractor in any of the subcontractor certifications required by this Affidavit is false, incomplete, or inaccurate. Contractor shall insert adequate provisions in all subcontracts to allow it to terminate subcontracts as required by this paragraph.
- D. The following civil and criminal penalties, among others, may apply:

A Contractor who makes a false statement material to Part II(A)(2) of this certification commits a Class 3 Felony. 720 ILCS 5/33E-11(b). Making a false statement concerning Part III(A) of this certification is a Class A misdemeanor, voids the Contract and allows the City to recover all amounts paid to the Contractor under the Contract in a civil action. 65 ILCS 5/11-42.1-1.
- E. This Disclosure Affidavit, some or all of the information provided herein, and any attachments may be made available to the public on the Internet, in response to a Freedom of Information Act request, or otherwise. By completing and signing this Disclosure Affidavit, bidder/proposer waives and releases any possible rights or claims it may have against the City in connection with the public release of any information contained in the completed Disclosure Affidavit and any attachments.

Disclosure Affidavit

PART X. VERIFICATION

Under penalty of perjury, I certify that I am authorized to execute this Disclosure Affidavit on behalf of the Contractor, that I have personal knowledge of all the certifications made herein, and that the same are true.

Signature of Authorized Officer
Jean-Francois Delaux
Name of Authorized Officer (Print or Type)

Chief Executive Officer
Title
011-44-208-326-7832
Business Telephone Number

Subscribed and sworn to before me this 3rd day
of June 2002
[Signature]
Notary Public

CINDY SAMUEL
Notary Public, State of New York
No. 01SA6047888
Qualified in New York County
Commission Expires Sept. 18, 2002

Disclosure Affidavit

Notes

1. Business entities are affiliated if, directly or indirectly, one controls or has the power to control the other, or if a third person controls or has the power to control both entities. Indicia of control include without limitation: interlocking management or ownership identity of interests among family members; shared facilities and equipment; common use of employees; or organization of another business entity using substantially the same management, ownership or principals as the first entity.
2. "Environmental Restriction" means any statute, ordinance, rule, regulation, permit, permit condition, order or directive relating to or imposing liability or standards of conduct concerning the release or threatened release of hazardous materials, special wastes or other contaminants into the environment, and to the generation, use, storage, transportation or disposal of construction debris, bulk waste, refuse, garbage, solid wastes, hazardous materials, special wastes or other contaminants, including but not limited to (1) the Comprehensive Environmental Response Compensation and Liability Act (42 U.S.C. § 9601 *et seq.*); (2) the Hazardous Material Transportation Act (49 U.S.C. § 1801 *et seq.*); (3) the Resource Conservation and Recovery Act of 1976 (42 U.S.C. § 6901 *et seq.*); (4) the Clean Water Act (33 U.S.C. § 1251 *et seq.*); (5) the Clean Air Act (42 U.S.C. § 7401 *et seq.*); (6) the Toxic Substances Control Act of 1976 (15 U.S.C. § 2601 *et seq.*); (7) the Safe Drinking Water Act (42 U.S.C. § 300f); (8) the Occupational Health and Safety Act of 1970 (29 U.S.C. § 651 *et seq.*); (9) the Emergency Planning and Community Right to Know Act (42 U.S.C. § 11001 *et seq.*); and (10) the Illinois Environmental Protection Act (415 ILCS 5/1 through 5/56.6).

EXHIBIT A

JCDECAUX S A

Response to Disclosure Affidavit Questions I.A.2 and I.A.3

Supervisory Board:

Jean-Claude Décaux	President
Jean Pierre Decaux	Member
Christian Blanc	Member
Pierre-Alain Pariente	Member

Executive Board

Jean-Francois Decaux	President
Jean-Charles Decaux	Chief Executive
Robert Caudron	COO
Gerard Degonse	CFO
Jeremy John Male	Member

Ownership interests:

JCDecaux Holding SA	69.523%
Public	27.579%
Jean Francois Decaux	1.099%
Jean-Charles Decaux	0.932%
Jean-Sebastien Decaux	0.387%
Jean-Marie Decaux	0.258%
Employees	0.133%
Jean-Pierre Decaux	0.004%
Robert Caudron	0.011%
Annick Piraud	0.008%
Jean-Claude Decaux	0.004%
Danielle Decaux	0.001%
Christian Blanc	2 shares
Pierre-Alain Pariente	2 shares

All shares are of the same class; there are no preferred shares or shares with double voting rights.

* There are 22 million shares with 20,500 shareholders. No person from the "Public" owns 7.5% or more of the shares; in fact no person from the public owns more than 2% of the company.

DISCLOSURE AFFIDAVIT FOR CONTRACTS AND CONCESSION AGREEMENTS NOT INVOLVING FEDERAL FUNDS

Every individual or entity submitting a bid or proposal to the City of Chicago for a contract or concession agreement not involving federal funds must complete this Disclosure Affidavit (hereafter "Disclosure Affidavit" or "Affidavit"). If the bidder/proposer is a joint venture, the joint venture and each of the joint venture partners must complete a Disclosure Affidavit.

Please print or type all responses clearly and legibly. If you need additional space for a response, attach extra pages. Please indicate the question to which you are responding on any extra pages you attach.

For purposes of this Disclosure Affidavit, the term "Contract" refers to the contract, concession, modification, amendment, extension, or other action in connection with which you are submitting the Disclosure Affidavit.

Please note that this Disclosure Affidavit requires bidders/proposers to obtain various certifications from their subcontractors before the subcontractors may perform any work under the Contract. The terms of the required subcontractor certifications are set forth below in Parts II and IV.

After reviewing your completed Disclosure Affidavit, the Corporation Counsel or the Purchasing Agent may require additional information to achieve full disclosure relevant to the bid, proposal, or other application.

Project Name: Coordinated Street Furniture Program

Discloser Bidder/Proposer Name: JCDecaux Holding SA

Purchase Order No.: B91557601

Bidder/Proposer Business Address: 17 Rue Soyer
92200 Neuilly sur Seine FRANCE

Goods or services to be provided under this Contract: Street Furniture

City department to which you are submitting this form (check one):

- Purchasing
- Other: _____

The undersigned, Jean-Francois Decaux as Directeur Général Délégué and on behalf of JCDecaux Holding SA ("Bidder/Proposer" or "Contractor"), having been duly sworn under oath certifies as follows:
(Name) (Title) (Business Name) (Parent Company of JCDecaux SA)

PART I. DISCLOSURE OF OWNERSHIP INTERESTS

Indicate below whether the bidder/proposer is an individual or a legal entity and, if a legal entity, indicate the type of entity. Then complete Part (A), (B), (C), or (D) below, as applicable. All bidders/proposers must complete Part (E). For bidders/proposers that are sole proprietorships, Part (E) is the only section of Part I that must be completed.

- | | |
|-----------------------------------------------------|-------------------------------------------------------------------|
| <input type="checkbox"/> Individual | <input type="checkbox"/> Limited liability company |
| <input type="checkbox"/> Business corporation | <input type="checkbox"/> Partnership |
| <input type="checkbox"/> Not-for-profit corporation | <input type="checkbox"/> Joint venture |
| <input type="checkbox"/> Sole proprietorship | <input checked="" type="checkbox"/> Other: <u>Société Anonyme</u> |

Disclosure Affidavit

A. CORPORATIONS (FOR-PROFIT AND NOT-FOR-PROFIT)

French Société Anonyme
(similar to a corporation)

- Incorporated in the State of _____
- List below the name and title of all officers of the corporation:

Name	Title
Sec Exhibit A	
_____	_____
_____	_____

- List below the name and title of all directors of the corporation:

Name	Title
Sec Exhibit A	
_____	_____
_____	_____

TO BE COMPLETED BY FOR-PROFIT CORPORATIONS ONLY:

- If there are fewer than 100 shareholders, list below the name, business address, and percentage of ownership interest of each shareholder:

Name	Business Address	Ownership Interest
Sec Exhibit A	_____	_____ %
_____	_____	_____ %
_____	_____	_____ %

- If there are 100 or more shareholders, list below the name, business address, and percentage of ownership interest for each shareholder who owns shares equal to or in excess of 7.5% of the proportionate ownership of the corporation:

Name	Business Address	Ownership Interest
_____	_____	_____ %
_____	_____	_____ %
_____	_____	_____ %

TO BE COMPLETED BY NOT-FOR-PROFIT CORPORATIONS ONLY:

List below the name, business address, and percentage of control of each member. If there are no members, write "none".

Name	Business Address	Percentage Control
_____	_____	_____ %
_____	_____	_____ %
_____	_____	_____ %

Disclosure Affidavit

B. PARTNERSHIPS

List below the name and business address of each partner and the percentage of ownership interest of each therein:

Name	Business Address	Ownership Interest
_____	_____	_____ %
_____	_____	_____ %
_____	_____	_____ %

C. LIMITED LIABILITY COMPANIES

1. List below the names and titles of the officers, if any. If there are no officers, write "none".

Name	Title
_____	_____
_____	_____
_____	_____

2. List below the name, business address and percentage of ownership interest of each (i) member and (ii) manager:

Name	Business Address	Ownership Interest
_____	_____	_____ %
_____	_____	_____ %
_____	_____	_____ %

D. LAND TRUSTS, BUSINESS TRUSTS, ESTATES AND OTHER SIMILAR ENTITIES

1. Trust name and number, or other information identifying the trust: _____

2. List below the name and business address of all trustees:

Name	Business Address
_____	_____
_____	_____
_____	_____

3. List below the name, business address and percentage of ownership interest of all beneficiaries:

Name	Business Address	Ownership Interest
_____	_____	_____ %
_____	_____	_____ %
_____	_____	_____ %

Disclosure Affidavit

E. ADDITIONAL INFORMATION -- TO BE COMPLETED BY ALL BIDDERS/PROPOSERS

1. Is any ownership interest in the bidder/proposer held by one or more agents or nominees on behalf of another individual or legal entity?

[] Yes [X] No

If so, list below each principal's name, business address, percentage of ownership interest, and the name of the principal's agent or nominee:

Name	Business Address	Ownership Interest	Agent/Nominee
_____	_____	_____%	_____
_____	_____	_____%	_____
_____	_____	_____%	_____

2. Is the bidder/proposer, or any ownership interest in the bidder/proposer, constructively controlled by another individual or legal entity, other than an agent or nominee disclosed above?

[] Yes [X] No

If so, list below the name and business address of each individual or entity possessing constructive control, the party whose interest is controlled, and the relationship between the two under which the control is or may be exercised:

Name	Business Address	Name of Party Whose Interest is Controlled	Relationship
_____	_____	_____	_____
_____	_____	_____	_____
_____	_____	_____	_____

3. Is any stock or beneficial interest in the bidder/proposer held by a corporation or other legal entity?

[] Yes [X] No

If so, each such corporation or other legal entity must make all disclosures requested in Part I (Disclosure of Ownership Interests) of this Disclosure Affidavit and must certify all information provided.

NOTE: Pursuant to Section 2-154-020 of the Municipal Code of Chicago, the information provided in Part I must be kept current. In the event of material changes, the bidder/proposer must supplement this Affidavit, up to the time the City takes action on the bid, proposal, or other application for which this Affidavit is being submitted.

PART II. CERTIFICATION REGARDING PROHIBITED CONDUCT

A. CONTRACTOR

1. The Contractor or any subcontractor to be used in the performance of this Contract, or any affiliated entity¹ of the Contractor or any such subcontractor, or any responsible official thereof, or, if acting pursuant to the direction or authorization of a responsible official thereof, any official, agent or employee of the Contractor, any such subcontractor or any such affiliated entity, has not, during a period of three (3) years prior to the date of execution of this Affidavit or, if a subcontractor or subcontractor's affiliated entity, during a period of three (3) years prior to the date of award of the subcontract:

Disclosure Affidavit

- a. Bribe or attempted to bribe, or been convicted of bribery or attempting to bribe, a public officer or employee of the City of Chicago, the State of Illinois, any agency of the Federal government or any State or local government in the United States, in that officer's or employee's official capacity; or
 - b. Agreed or colluded with other bidders or prospective bidders, or been a party to any such agreement or been convicted of agreement or collusion among bidders or prospective bidders, in restraint of freedom of competition by agreement to bid a fixed price or otherwise; or
 - c. Made an admission of guilt of any conduct described in 1(a) and (b) above which is a matter of record but has not been prosecuted for such conduct.
2. Neither the Contractor nor any employee, official, agent, or, for partnerships and joint ventures, partner of the Contractor is barred from contracting with any unit of State or local government as a result of engaging in or being convicted of (a) bid-rigging in violation of 720 ILCS 5/33E-3; (b) bid-rotating in violation of 720 ILCS 5/33E-4; or (c) any similar offense of any State of the United States which contains the same elements as either bid rigging or bid-rotating.
3. The Contractor and its principals, as defined in 49 CFR Sec. 29.105:
- a. Are not currently debarred, suspended, proposed for debarment, declared ineligible, or voluntarily excluded by any Federal, State or local department or agency;
 - b. Have not within a three (3) year period preceding this Affidavit been convicted of a criminal offense in connection with obtaining, attempting to obtain, or performing a public (Federal, State, local) transaction or Contract under a public transaction; a violation of Federal or State antitrust statutes; fraud; embezzlement; theft; forgery; bribery; falsification or destruction of records; making false statements; or receiving stolen property; or had a civil judgment rendered against them for commission of fraud;
 - c. Are not currently indicted for or otherwise criminally or civilly charged by a government entity (Federal, State or local) with commission of any of the offenses enumerated in paragraph (3)(b) above; and
 - d. Have not within a three (3) year period preceding the date of this Affidavit had one or more public transactions (Federal, State or local) terminated for cause or default.
4. If the Contractor is unable to certify to any of the above statements [Part II(A)(1)-(3)], Contractor shall explain below. Attach additional pages if necessary. _____

_____ [If no explanation appears or begins on the lines above, it shall be conclusively presumed that the Contractor certifies to each of the above statements.]

B. SUBCONTRACTORS

1. The Contractor has obtained certifications in form and substance equal to Part II(A)(1)-(3) of this Affidavit from all subcontractors that the Contractor presently intends to use to perform this Contract. As to subcontractors to be used to perform this Contract who are not yet known by the Contractor, the Contractor will obtain certifications in form and substance equal to Part II(A)(1)-(3) of this Affidavit prior to using them as subcontractors.
2. The Contractor shall not, without the prior written consent of the City, use any subcontractors to perform this Contract if the Contractor, based on information contained in the subcontractor certification or any other information known or obtained by the Contractor, has reason to believe that, within three (3) years prior to the award of any subcontract, the subcontractor or such subcontractor's affiliated entity, or any

Disclosure Affidavit

official, agent, or, employee of such subcontractor or subcontractor's affiliated entity, has engaged in, been convicted of, or made an admission of guilt of any of the conduct listed in Part II(A)(1); or that the subcontractor, an employee, official, agent, or, for partnerships and joint ventures, partner thereof is barred from contracting with any unit of State or local government as a result of engaging in or being convicted of bid-rigging, bid-rotating, or any similar offense; or that any of the circumstances set forth in Part II (A)(3) applies to the subcontractor or its principals. Furthermore, the Contractor shall not, without the prior written consent of the City, use as a subcontractor any individual, firm, partnership, corporation, joint venture or other entity from which the Contractor is unable to obtain a certification in form and substance equal to Part II(A)(1)-(3) of this Affidavit or which the Contractor has reason to believe cannot provide a truthful certification..

3. The Contractor shall maintain all subcontractors' certifications required by Paragraph (1) above for the duration of the Contract and shall make such certifications promptly available to the City upon request.

PART III. CERTIFICATION REGARDING TAXES, FEES AND LITIGATION

A. STATE TAX DELINQUENCIES

Contractor is not delinquent in the payment of any tax administered by the Illinois Department of Revenue or, if delinquent, Contractor is contesting its liability for the tax or the amount of the tax in accordance with the procedures established by the appropriate Revenue Act. Alternatively, Contractor has entered into an agreement with the Illinois Department of Revenue for the payment of all such taxes that are due and is in compliance with such agreement.

B. OTHER TAXES/FEES

Contractor is not delinquent in paying any fine, fee, tax or other charge owed to the City of Chicago.

C. JUDICIAL OR ADMINISTRATIVE PROCEEDINGS

Contractor is not a party to any pending lawsuits against the City nor has Contractor been sued by the City or its agents in any judicial or administrative proceeding within the ten (10) year period preceding execution of this Affidavit.

D. EXCEPTIONS

If the Contractor is unable to certify to any of the above statements [Part III (A)-(C)], Contractor shall explain below. In the case of any judicial or administrative proceedings, provide the (1) case name, (2) docket number; (3) court in which the action is or was pending; and (4) a brief description of each proceeding. Attach additional pages if necessary.

_____ [If no explanation appears or begins on the lines above, it shall be conclusively presumed that the Contractor certifies to each of the above statements.]

PART IV. CERTIFICATION REGARDING ENVIRONMENTAL COMPLIANCE

A. CONTRACTOR

1. Neither the Contractor nor any affiliated entity of the Contractor has, during a period of five (5) years prior to the date of execution of this Affidavit, (a) violated or engaged in any conduct which violated Sections 7-28-440 or 11-4-1500 or Article XIV of Chapter 11-4 or Chapters 7-28 or 11-4 of the Municipal Code or any other Environmental Restriction², (b) received notice of any claim, demand or action, including but not limited to citations and warrants, from the City of Chicago, the State of Illinois, the Federal government, any State or political subdivision thereof, or any agency, court or body of the Federal government or any State or political subdivision thereof, exercising executive, legislative, judicial, regulatory or administrative functions, relating to a violation or alleged violation of Sections 7-28-440 or 11-4-1500 or Article XIV of Chapter 11-4 or Chapters 7-28 or 11-4 of the Municipal Code or any other Environmental Restriction; or

Disclosure Affidavit

twenty percent (20%) interest in the Contractor, and an individual or entity has a fifty percent (50%) interest in Corporation B, then such individual indirectly has a ten percent (10%) interest in the Contractor and the individual is a Substantial Owner of the Contractor. If Corporation B is held by another entity, then this analysis must be applied to that entity.

If Contractor's response below is #1 or #2, then all of the Contractor's Substantial Owners must remain in compliance with any such child support obligations (A) throughout the term of the Contract and any extensions thereof; or (B) until the performance of the Contract is completed, whichever is later. Failure of Contractor's Substantial Owners to remain in compliance with their child support obligations in the manner set forth in either (A) or (B) constitutes an event of default.

Check one:

1. No Substantial Owner has been declared in arrearage on any child support obligations by the Circuit Court of Cook County or by another Illinois court of competent jurisdiction.
2. The Circuit Court of Cook County or another Illinois court of competent jurisdiction has issued an order declaring one or more Substantial Owners in arrearage on their child support obligations. All such Substantial Owners, however, have entered into court-approved agreements for the payment of all such child support owed, and all such Substantial Owners are in compliance with such agreements.
3. The Circuit Court of Cook County or another Illinois court of competent jurisdiction has issued an order declaring one or more Substantial Owners in arrearage on child support obligations and (1) at least one such Substantial Owner has not entered into a court-approved agreement for the payment of all such child support owed; or (2) at least one such Substantial Owner is not in compliance with a court-approved agreement for the payment of all such child support owed; or both (1) and (2).
4. There are no Substantial Owners.

PART VII. AFFIDAVIT OF LOCAL BUSINESS

If this is a competitively bid Contract funded in whole by City funds, Contractor should complete this Section.

A. Is bidder/proposer a "Local Business" as defined by the provisions of this Specification?
[] Yes [] No

B. How many persons are currently employed by bidder/proposer? _____

C. Does bidder/proposer have business locations outside the City of Chicago?
[] Yes [] No

If so, list such bidder/proposer's business addresses.

D. How many of bidder/proposer's current employees work at City of Chicago locations? _____

E. Is bidder/proposer subject to City of Chicago taxes (including the Head Tax)?

[] Yes [] No

PART VIII. CERTIFICATION REGARDING ELECTED OFFICIALS' BUSINESS RELATIONSHIPS

An ordinance approved by the City Council of the City of Chicago on December 2, 1998, requires that all persons or entities submitting this statement shall indicate whether they had a business relationship with a city elected official in the 12 months prior to the date upon which the statement is signed. A "business relationship" means any contractual or other private business dealing of an official, or his or her spouse, or of any entity in which an official or his or her spouse has a financial interest, with a person or entity which entitles an official to compensation or

Disclosure Affidavit

payment in the amount of \$2,500 or more in a calendar year; provided, however, a financial interest shall not include: (i) any ownership through purchase at fair market value or inheritance of less than one percent of the shares of a corporation, or any corporate subsidiary, parent or affiliate thereof, regardless of the value of or dividends on such share, if such shares are registered on a securities exchange pursuant to the Securities Exchange Act of 1934, as amended; (ii) the authorized compensation paid to an official or employee for his office or employment; (iii) any economic benefit provided equally to all residents of the city; (iv) a time or demand deposit in a financial institution, or (v) an endowment or insurance policy of annuity contract purchased from an insurance company. A "contractual or other private business dealing" shall not include any employment relationship of an official's spouse with an entity when such spouse has no discretion concerning or input relating to the relationship between that entity and the city. **Please indicate below whether the person or entity submitting this statement had a business relationship with a city elected official in the 12 months prior to the date upon which this statement is signed.**

Has the Contractor had a "business relationship" with any City elected official(s) in the 12 months prior to the date of execution of this Disclosure Affidavit?

[] Yes [X] No

If yes, please identify below the name(s) of such City elected official(s) and describe such relationship(s):

PART IX. INCORPORATION INTO CONTRACT, COMPLIANCE AND PENALTIES

The bidder/proposer understands and agrees that:

- A. The above certifications [Parts I-VII] shall become part of any Contract awarded to the bidder/proposer and are a material inducement to the City's execution of the Contract or other action with respect to which this Disclosure Affidavit is being executed and delivered on behalf of the bidder/proposer. Furthermore, the bidder/proposer shall comply with these certifications during the term and/or performance of the Contract or other action.
- B. If the City determines that any information provided herein is false, incomplete or inaccurate, the City may terminate the Contract or other transaction, terminate the applicant's participation in the Contract or other transaction and/or decline to allow the applicant to participate in other Contracts or transactions with the City.
- C. Contractor will terminate its subcontract with any subcontractor, if the City so demands, if the City determines that any information provided by a subcontractor in any of the subcontractor certifications required by this Affidavit is false, incomplete, or inaccurate. Contractor shall insert adequate provisions in all subcontracts to allow it to terminate subcontracts as required by this paragraph.
- D. The following civil and criminal penalties, among others, may apply:
 - A Contractor who makes a false statement material to Part II(A)(2) of this certification commits a Class 3 Felony. 720 ILCS 5/33E-11(b). Making a false statement concerning Part III(A) of this certification is a Class A misdemeanor, voids the Contract and allows the City to recover all amounts paid to the Contractor under the Contract in a civil action. 65 ILCS 5/11-42.1-1.
- E. This Disclosure Affidavit, some or all of the information provided herein, and any attachments may be made available to the public on the Internet, in response to a Freedom of Information Act request, or otherwise. By completing and signing this Disclosure Affidavit, bidder/proposer waives and releases any possible rights or claims it may have against the City in connection with the public release of any information contained in the completed Disclosure Affidavit and any attachments.

Disclosure Affidavit

PART X VERIFICATION

Under penalty of perjury, I certify that I am authorized to execute this Disclosure Affidavit on behalf of the Contractor, that I have personal knowledge of all the certifications made herein, and that the same are true.

[Signature]
Signature of Authorized Officer

Jean-Francois Decaux
Name of Authorized Officer (Print or Type)

Directeur Général Délégué
Title

01-44-208-326-7832
Business Telephone Number

Subscribed and sworn to before me this 3rd day
of June 2002

[Signature]
Notary Public

CINDY SAMUEL
Notary Public, State of New York
No. 01SA6047888
Qualified in New York County
Commission Expires Sept. 18, 2002

Disclosure Affidavit

Notes

1. Business entities are affiliated if, directly or indirectly, one controls or has the power to control the other, or if a third person controls or has the power to control both entities. Indicia of control include without limitation: interlocking management or ownership identity of interests among family members; shared facilities and equipment; common use of employees; or organization of another business entity using substantially the same management, ownership or principals as the first entity.
2. "Environmental Restriction" means any statute, ordinance, rule, regulation, permit, permit condition, order or directive relating to or imposing liability or standards of conduct concerning the release or threatened release of hazardous materials, special wastes or other contaminants into the environment, and to the generation, use, storage, transportation or disposal of construction debris, bulk waste, refuse, garbage, solid wastes, hazardous materials, special wastes or other contaminants, including but not limited to (1) the Comprehensive Environmental Response Compensation and Liability Act (42 U.S.C. § 9601 *et seq.*); (2) the Hazardous Material Transportation Act (49 U.S.C. § 1801 *et seq.*); (3) the Resource Conservation and Recovery Act of 1976 (42 U.S.C. § 6901 *et seq.*); (4) the Clean Water Act (33 U.S.C. § 1251 *et seq.*); (5) the Clean Air Act (42 U.S.C. § 7401 *et seq.*); (6) the Toxic Substances Control Act of 1976 (15 U.S.C. § 2601 *et seq.*); (7) the Safe Drinking Water Act (42 U.S.C. § 300f); (8) the Occupational Health and Safety Act of 1970 (29 U.S.C. § 651 *et seq.*); (9) the Emergency Planning and Community Right to Know Act (42 U.S.C. § 11001 *et seq.*); and (10) the Illinois Environmental Protection Act (415 ILCS 5/1 through 5/56.6).

EXHIBIT A

JCDECAUX HOLDING S A

Response to Disclosure Affidavit Questions I.A.2 and I.A.3

Board of Directors

Jean-Claude Decaux	Chairman
Jean-Charles Decaux	
Jean-Francois Decaux	

Officers

Jean-Claude Decaux	President & CEO
Jean-Charles Decaux	Directeur General (Delegated)
Jean-François Decaux	Directeur General (Delegated)
Jean-Sebastien Decaux	Directeur General (Delegated)

Ownership Interests

Jean-Claude Decaux	84.002%
Jean-Francois Decaux	11.333%
Jean-Charles Decaux	2.333%
Jean-Sebastien Decaux	2.333%
Jean-Pierre Decaux	0.003%
Robert Caudron	0.003%
Danielle Decaux	0.002%

EXHIBIT 5

Evidence of Insurance

*** PLS PRINT NAME ***

2002-Jun-07 11:27am From-CITY HALL LAB DEPT 13127443332 T-708 P.012/002 F-481

(Rev. 10/00)

Issue Date: 6-16-2002
 CAYON Initials: _____

INSURANCE CERTIFICATE OF COVERAGE

Named Insured: JC Decaux Chicago, LLC Specification #: _____
 Address: 3 PARK AVENUE RFP: _____
 New York, NY (Number and Street) 10016 Project #: _____
 (City) (State) (Zip) Contract #:

Description of Operation/Location
 The insurance policies and endorsements indicated below have been issued to the designated named insured with the policy limits as set forth herein covering the operation described within the contract involving the named insured and the City of Chicago. The Certificate Issuer agrees that in the event of cancellation, non-renewal or material change involving the indicated policies, the issuer will provide at least sixty (60) days prior written notice of such change to the City of Chicago at the address shown on this Certificate. This certificate is issued to the City of Chicago in consideration of the contract entered into with the named insured, and it is mutually understood that the City of Chicago relies on this certificate as a basis for negotiating such agreement with the named insured.

Type of Insurance	Insurer Name	Policy Number	Expiration Date	Limits of Liability All Limits in Thousands
General Liability <input checked="" type="checkbox"/> Claims made <input type="checkbox"/> Occurrence <input checked="" type="checkbox"/> Premises-Operations <input checked="" type="checkbox"/> Explosion/Collapse Underground <input checked="" type="checkbox"/> Products/Completed-Operations <input checked="" type="checkbox"/> Blanket Contractual <input checked="" type="checkbox"/> Broad Form Property Damage <input checked="" type="checkbox"/> Independent Contractors <input checked="" type="checkbox"/> Personal Injury <input type="checkbox"/> Pollution	St. Paul Fire & Marine Ins. Co.	IT066 01203	1/1/2003	CSI Per Occurrence \$1,000 General Aggregate \$2,000 Products/Completed Operations Aggregate \$1,000
Automobile Liability	Illinois National	CA359 4380	1-1-2003	CSI Per Occurrence \$1,000
<input checked="" type="checkbox"/> Excess Liability <input type="checkbox"/> Umbrella Liability	St. Paul Fire & Marine	IT066 01203	1-1-2003	Each Occurrence \$5,500
Worker's Compensation and Employer's Liability	Commerce & Industry	WC359 1452	1-1-2003	Statutory/EMROL Employer Liability \$1,000
Builders Risk/Course of Construction				Amount of Contract
Professional Liability	Zurich BOC491	562	6-27-2003	\$1,000
Owner Contractor Protective	American			\$
Other				\$

- a) Each insurance policy required by this agreement, excepting policies for worker's compensation and professional liability, will read: "The City of Chicago is an additional insured as respects operations and activities of, or on behalf of the named insured, performed under contract with or permit from the City of Chicago."
- b) The General, Automobile and Excess/Umbrella Liability Policies described provide for severability of interest (cross facility) applicable to the named insured and the City.
- c) Worker's Compensation and Property Insurer shall waive all rights of subrogation against the City of Chicago.
- d) The receipt of this certificate by the City does not constitute agreement by the City that the insurance requirements in the contract have been fully met, or that the insurance policies indicated by this certificate are in compliance with all contract requirements.

Name and Address of Certificate Holder and Recipient of Notice
 Signature of Willis of New Jersey Inc.
 Certificate Holder/Additional Insured Agency/Company: Willis of New Jersey Inc.
 City of Chicago Address 25 B Vreeland Road Florham Park, NJ 07932
 Department of Procurement Services Telephone (973) 410-4604
 121 N. LaSalle St. #403
 Chicago, IL 60602

For City use only
 Name of City Department requesting certificate: (Using Dept.): _____
 Address: _____ ZIP Code: _____ Attention: _____

JUN 27 2002 15:38 FR JCD NEW YORK 2126148125 TO 919734104600 P.04/04

Exhibit 6

Performance and Payment Bond(s)

CONTRACTOR'S PERFORMANCE & PAYMENT BOND

Know All Men by these Presents, That we,

Principal, hereinafter referred to as Contractor, and

Surety

of the County of Cook and State of Illinois, are held and firmly bound unto the CITY OF CHICAGO in the penal sum of lawful money of the United States, for the payment of which sum of money, well and truly to be made, we bind ourselves, our heirs, executors, administrators, successors and assigns, jointly and severally, firmly by these presents.

Sealed with our seals and dated this

day of

A.D., 20

The Condition of the Above Obligation is such,

That whereas the above bounden Contractor has entered into a certain contract with the CITY OF CHICAGO, bearing Contract No. _____ and Specification No. _____ all in conformity with said contract, for,

The said contract is incorporated herein by reference in its entirety, including without limitation, any and all indemnification provisions.

Now, if the said Contractor shall in all respects well and truly keep and perform the said contract on its part, in accordance with the terms and provisions of all of the Contract Documents comprising said contract, and in the time and manner therein prescribed, and further shall save, indemnify, and keep harmless the City of Chicago against all loss, damages, claims, liabilities, judgements, costs and expenses which may in anywise accrue against said City of Chicago, in consequence of the granting of said contract, or which may in anywise result therefrom, or which may result from strict liability, or which may in anywise result from any injuries to, or death of, any person, or damage to any real or personal property, arising directly or indirectly from or in connection with, work performed or to be performed under said contract by said Contractor, its Agents, Employees or Workmen, assignees, subcontractors, or anyone else, in any respect whatever, or which may result on account of any infringement of any patent by reason of the materials, machinery, devices or apparatus used in the performance of said contract, and moreover, shall pay to said City any sum or sums of money determined by the Purchasing Agent, and/or by a court of competent jurisdiction, to be due said City by reason of any failure or neglect in the performance of the requirements of said contract, wherefore the said Purchasing Agent shall have elected to suspend or cancel the same, and shall pay all claims and demands whatsoever, which may accrue to each and every materialman and subcontractor, and to each and every person who shall be employed by the said Contractor or by its assignees and subcontractors, in or about the performance of said contract, and shall insure its liability to pay the compensation, and shall pay all claims and demands for compensation which may accrue to each and every person who shall be employed by them or any of them in or about the performance of said contract, or which shall accrue to the beneficiaries or dependents of any such person, under the provisions of the Workers' Compensation Act, 820 ILCS 305, as amended, and the Workers' Occupational Disease Act, 820 ILCS 310, as amended (hereinafter referred to as "Acts") then is this obligation to be null and void, otherwise to remain in full force and effect.

And it is hereby expressly understood and agreed, and made a condition hereof, that any judgement rendered against said City in any suit based upon any loss, damages, claims, liabilities, judgements, costs or expenses which may in anywise accrue against said City as a consequence of the granting of said contract, or which may in anywise result therefrom, or which may in anywise result from any injuries to, or death of, any person, or damage to any real or personal property, arising directly or indirectly from, or in connection with, work performed, or to be performed under said contract by said Contractor or its agents, employees or workmen, assignees, subcontractors, or anyone else and also any decision of the Industrial Commission of the State of Illinois, and any order of court based upon such decision, or judgement thereon, rendered against said City of Chicago in any suit or claim arising under the aforementioned Acts when notice of the pendency or arbitration proceedings or suit shall have been given said Contractor, shall be conclusive against each and all parties to this obligation, as to amount, liability and all other things pertaining thereto.

Every person furnishing material or performing labor in the performance of said contract, either as an individual, as a subcontractor, or otherwise, shall have the right to sue on this bond in the name of the City of Chicago for his use and benefit and in such suit said person as plaintiff, shall file a copy of this bond, certified by the party or parties in whose charge this bond shall be, which copy shall be, unless execution thereof be denied under oath, prima facie evidence of the execution and delivery of the original; provided, that nothing in this bond contained shall be taken to make the City of Chicago liable to any subcontractor, materialman, laborer or to any other person to any greater extent than it would have been liable prior to the enactment of the Public Construction Bond Act, 30 ILCS 550, as amended; provided further, that any person having a claim for labor and materials furnished in the performance of this contract shall have no right of action unless he shall have filed a verified notice of such claim with the Clerk of the City of Chicago within 180 days after the date of the last item of work or the furnishing of the last item of materials, and shall have furnished a copy of such verified notice to the contractor within 10 days of the filing of the notice with the City of Chicago. Such claim shall be verified and shall contain the name and address of the claimant, the business address of the claimant within the State of Illinois, if any, or if the claimant be a foreign corporation having no place of business with the State the principal place of business of said corporation, and in all cases of partnership the names and residences of each of the partners, the name of the contractor for the City of Chicago, the name of the person, firm or corporation by whom the claimant was employed or to whom such claimant furnished materials, the amount of the claim and a brief description of the public improvement for the construction or installation of which the contract is to be performed. Provided, further, that no defect in the notice herein provided for shall deprive the claimant of his right of action under the terms and provisions of this bond unless it shall affirmatively appear that such defect has prejudiced the rights of an interested party asserting the same; provided, further, that no action shall be brought until the expiration of one hundred twenty (120) days after the date of the last item of work or of the furnishing of the last item of material, except in cases where the final settlement between the City of Chicago and the Contractor shall have been made prior to the expiration of the 120 day period in which case action may be taken immediately following such final settlement, and provided, further, that no action of any kind shall be brought later than six (6) months after the acceptance by the City of Chicago of the completion of work. Any suit upon this bond shall be brought only in a circuit court of the State of Illinois in the judicial district in which the contract shall have been performed.

The said Surety, for value received, hereby stipulates and agrees that no change, extension of time, alteration or addition to the terms of any of the Contract Documents comprising said contract, or to the work to be performed thereunder, shall in anywise affect the obligations on this bond, and it does hereby waive notice of any such change, extension of time, alteration or addition to the terms of said Contract Documents or to the work.

Approved _____, 20____ (Seal)

_____ (Seal)

_____ (Seal)

Purchasing Agent

_____ (Seal)

Approved as to form and legality: _____ (Seal)

_____ (Seal)

Assistant Corporation Counsel

**PRINCIPAL
IF CORPORATION**

**STATE OF ILLINOIS, }
COUNTY OF COOK, } ss.**

I, _____, a Notary Public in and for the County and State
aforesaid, DO HEREBY CERTIFY that _____ President and
_____ Secretary of the _____

who are personally known to me to be the same persons whose names are subscribed in the foregoing instrument as
such _____ President and _____ Secretary, appeared
before me this day in person and acknowledged that they signed, sealed and delivered the said instrument of writing as
their free and voluntary act, and as the free and voluntary act of the said _____
for the uses and purposes therein set forth, and caused the corporate seal of said Company to be thereto attached.

GIVEN under my hand and Notarial Seal this _____ day of _____ 20____

Notary Public

SURETY, IF CORPORATE

**STATE OF ILLINOIS, }
COUNTY OF COOK, } ss.**

I, _____, a Notary Public in and for the County and State
aforesaid, DO HEREBY CERTIFY that _____

_____ of the _____ who _____ personally known
to be the same person _____ whose name _____ subscribed in the foregoing instrument as such _____
_____, appeared before me this day in person and acknowledged that _____

signed, sealed and delivered the said instrument of writing as _____ free and voluntary act, and as the free
and voluntary act of the said _____
for the uses and purposes therein set forth, and caused the corporate seal of said Company to be thereto attached.

GIVEN under my hand and Notarial Seal this _____ day of _____ 20____

Notary Public

**PRINCIPAL
IF INDIVIDUAL**

**STATE OF ILLINOIS, }
COUNTY OF COOK, } ss.**

I, _____, a Notary Public in and for the County and State
aforesaid, DO HEREBY CERTIFY that _____

who _____ personally known to me to be the same persons whose name _____ subscribed in the foregoing
instrument, appeared before me this day in person and acknowledged that _____ he _____ signed, sealed and delivered the
said instrument of writing as _____ free and voluntary act, for the uses and purposes therein set forth.

GIVEN under my hand and Notarial Seal this _____ day of _____ 20____

Notary Public

EXHIBIT 7

List of Key Personnel and Schedule of Availability

Key Personnel:

Name:	Title:	Cell Phone/ Telephone No. / Pager No.
Nicolas Clochard-Bossuet*	Chief Operating Officer	312-795-3612/917-826-4381
Richard De Freitas*	Director of Operations	312-795-3600/202-257-3779

Schedule of Availability:

At least one person who is Key Personnel shall be available 24 hours per day, seven days per week.

*Must be based in the City of Chicago.

EXHIBIT 8

Additional Specifications Relating to Work to be Performed on the Public Way

The following specifications supplement the "Standard Specifications for Road and Bridge Construction", adopted January 1, 2002 (the "Standard Specifications") and the latest edition of the "Illinois Manual on Uniform Traffic Control Devices for Streets and Highways" in effect on the Commencement Date. In case of conflict with any part or parts of said specifications, the following specifications will take precedence and govern.

Unless otherwise specified, the Description, General Requirements and Method of Measurements for the following items shall be as stated in the appropriate sections of the Standard Specifications.

ITEM 1: TRAFFIC CONTROL AND PROTECTION: INCIDENTAL TO THE AGREEMENT

Work will be performed in accordance with Section 701 of the Standard Specifications, except as herein modified.

Description: The work includes furnishing, installation, maintenance, relocation and subsequent removal of all signs, signals, markings, traffic cones, barricades, warning lights, flaggers and other devices which are to be used for the purpose of regulating, warning or guiding traffic during the course of the proposed work.

General Requirements: Traffic Control will be in accordance with the applicable section of the Standard Specifications and the applicable guidelines contained in the Illinois Manual on Uniform Traffic Control Devices for Streets and Highways and this Agreement.

Special attention is called to Articles 107.09 and 107.14 of the Standard Specifications.

Special attention must be given to advance guide signs during these operations in order to keep barricade placement consistent with lane assignment. The Contractor must cover all traffic control devices which may be inconsistent with traffic patterns during the traffic from one construction stage to another.

The Contractor's vehicle will always move with and not against or across the flow of traffic. These vehicles will enter or leave work areas in a manner which will not be hazardous to or interfere with normal traffic and will not park or stop except within designated work areas. Personal vehicles will not be permitted to park within the right of way except in special areas designated by the Commissioner of CDOT.

The Contractor will immediately furnish a certified flagger or flaggers if in the opinion of the Commissioner of CDOT, the Contractor's construction means or methods warrant. If no flaggers are available the Contractor will cease operations until they become available.

All signs, signals, markings, traffic cones, barricades, warning lights, flaggers, and other traffic control devices must conform to the plans, specifications, special provisions and the latest edition of the "State of Illinois Manual on

Uniform Traffic Control Devices." The Contractor will obtain, erect, maintain, and remove all traffic control devices in accordance with Article 107.14 of the Standard Specifications. Placement and maintenance of all traffic control devices shall be as directed by the Commissioner of CDOT. The Commissioner of CDOT shall be the sole judge as to the acceptability of placement and maintenance of the traffic control devices prescribed in the appropriate standards.

The Contractor will insure that all barricades, signs, lights and other devices installed by him are operational every day, including Sunday and holidays. In the event of severe weather conditions, the Contractor will furnish any additional personal required to properly maintain all traffic control devices as directed by the Commissioner of CDOT.

The Contractor will be responsible for timely installation, maintenance, relocation and subsequent removal of all temporary signing, barricading and temporary striping necessary to accomplish these detours.

At the completion of each state of construction or whenever detour operations indicate that a relocation of a proposed or existing traffic control device is advisable as determined by the Commissioner of CDOT, the Contractor will remove all traffic control devices which are furnished, installed and maintained by him under this Agreement, and such devices will remain the property of the Contractor. Any traffic control devices furnished, installed and maintained by the City will be removed by City forces and will remain the property of the City. All traffic control devices must remain in place until specific authorization for relocation or removal is received from the Commissioner of CDOT.

The Contractor must be aware of the requirements for coordination of all work in this project and adjoining or overlapping projects and for coordination of barricade placement necessary to provide a uniform traffic detour pattern. The Contractor will not be permitted to erect, change or remove his detour barricade system without the prior approval of the Commissioner of CDOT.

The placement of barricades and warning signs for the required lane closures will be as specified herein and will proceed in the direction of the flow of traffic. The removal of all signs and barricades will begin at the end of the construction areas and proceed toward oncoming traffic.

Maintenance of Roadways: Beginning on the date when the Contractor begins work on this project the Contractor will assume responsibility for the normal maintenance of all existing roadways within the limits of the improvement. The normal maintenance will include all repair work deemed necessary by the Commissioner of CDOT but will not include snow removal operations.

Arrow Boards: A flashing arrow board meeting the requirements of Article 702.05 of the Standard Specifications must be operating at all times when a lane is closed to traffic on a multi-lane highway. Arrow boards will be provided and located in ahead-on position within each lane closure taper.

ITEM 2: EARTH EXCAVATION

Work under this item will be performed in accordance with Section 202 of the Standard Specifications except as herein modified.

Description: Earth Excavation will include that volume of material which must be removed to construct concrete foundation slab components.

Earth excavation will also include the satisfactory removal and disposal of all unsuitable material below the subgrade elevation.

General Requirements: After saw cutting (where required) and after excavating to the required subgrade level, the Commissioner of CDOT shall inspect the subgrade. Prior to placing any concrete material(s), the excavation level or sub-grade level will be compacted and, where possible, proof-rolled. The compacting and proof-rolling will detect soft or unstable pockets of material which will be removed and replaced as herein specified. The compacting and proof-rolling will be incidental to the work.

If the existing subgrade soil is not suitable for supporting the proposed loading as determined by the Commissioner of CDOT, the Contractor will remove the unsuitable subgrade soil below the proposed subgrade level to a depth as directed by the Commissioner of CDOT, compact and proof-roll the excavated area. If upon proof-rolling, the subgrade is still unsuitable, additional excavation may be required. No additional compensation will be made regardless of the number of times the area is compacted and proof-rolled.

CA1 or CA6 will be used to bring the subgrade to the proposed elevation as indicated under the item STABILIZATION STONE. STABILIZATION STONE is not considered part of this item.

Those areas of Subgrade which are not over excavated will also be compacted to 95 percent of maximum density as determined by AASHTO T-99.

No burning or use of explosive will be allowed.

Earth excavation will also include, where encountered, blocking of all abandoned sewers and duct lines.

ITEM 3: STABILIZATION STONE / SUBBASE GRANULAR MATERIAL

Description: This item will consist of furnishing and placing coarse aggregate having a CA1 or CA6 gradation meeting the requirements of Section 1004 of the Standard Specifications. Material requirements is at the discretion of the Commissioner of CDOT dependent upon conditions encountered.

General Requirements: The Stabilization Stone/Subbase Granular Material will be used under sub-base where the subgrade is deemed too unstable to support the proposed construction. This item will be used solely at the discretion of the Commissioner of CDOT. It is understood that a certain amount of Stabilization Stone/Subbase Granular Material may be displaced into the existing soil when the material is placed and compacted.

The unsuitable subgrade soil below the proposed subgrade level will be removed to a depth as directed by the Commissioner of CDOT; then as directed by the Commissioner of CDOT, either 1) place a layer of CA1 and compacted it into the existing subgrade until stable followed by a layer of CA6 compacted unit 95 percent of maximum density as determined by AASHTO T-99 is achieved; or 2) place only a layer of CA6 compacted until 95 percent of maximum density as determined by AASHTO T-99 is achieved.

ITEM 4: PORTLAND CEMENT CONCRETE (PCC) FOR FOUNDATIONS AND SLABS

Except as herein specified, PCC for foundations and slabs will be constructed in accordance with Section 1020 of the Standard Specifications (SSRBC).

Description: This item will consist of constructing Portland Cement Concrete foundations and slab at locations indicated on the plans or as ordered by the Commissioner of CDOT.

General Requirements:

Concrete will not be placed on a soft, frozen or non-compacted subbase.

The concrete will be consolidated with a vibrator inserted into the concrete and worked across the pour area before the finishing operations are started. The use of an external vibrator will be required.

P.C.C. will be cured in accordance with Article 1020.13.

Also included in this item is the excavation and disposal of any existing temporary stone regardless of type to the proposed sub-base elevation and the removal of any existing base course determined to be unstable.

ITEM 5: INSTALLATION OF CONDUIT/CABLE AND ELECTRICAL LINE CONNECTION

This work will consist of furnishing and installation of conduit, and installation of cable in conduit; as discussed below hereinafter.

SUB ITEM 5.1 CODE NO. M810000 CONDUIT INTRENCH GALVANIZED STEEL

Description: This work will consist of furnishing and installing conduits, fittings, and accessories, laid in trench as directed by the Commissioner of CDOT.

General Requirements: General requirements will be in accordance with Section 801 of the Standard Specifications, and in accordance with Bureau of Electricity Standards and the City of Chicago Electrical Code, except as modified herein.

Materials: Materials will be in accordance with the following Articles and of Section 1000 of the Standard Specifications - Materials, except as noted below:

<u>Item</u>	<u>Article/Paragraph</u>
IV. Rigid Metal Conduit	1085.15(a)
V. Rigid Nonmetallic Conduit	1085.15(b)

Galvanized rigid steel conduit will conform to the requirements of the City of Chicago Standard Specifications for "Rigid Steel Conduit, Zinc Coated".

Polyvinylchloride (PVC) conduit will conform to the requirements of National Electrical Manufacturers Association Standard, Publication No. TC2 for Schedule 40 conduit and Schedule 80 conduit.

Location: Conduits will be installed at locations as shown on the plans or as approved by the Commissioner of CDOT. Conduits will be installed in the shortest practicable line between points of termination, or under adverse conditions, as directed by the Commissioner of CDOT.

Installation: Installation of galvanized steel conduit will be in accordance with Article 810.03(a) of the Standard Specifications, except for paragraph (1), which is revised to include the following paragraphs:

"All conduit runs will be cleaned and swabbed before installation of electric cables. Crushed, obstructed or deformed conduit will not be accepted. The excavation for trenched conduit will be located at least 600 millimeters from the face of curb. All underground conduit will have a minimum depth of 750 millimeters below grade.

When multiple conduits in a common trench are required, no more than three (3) 75 millimeter or smaller conduits will be laid on a single, horizontal level. For (4) or more conduits will be installed on two (2) levels as directed by the Commissioner of CDOT".

Installation of PVC conduit will be in accordance with Article 810.03(b) of the Standard Specifications, except for paragraphs (4) and (5), which is revised to read as follows:

"(4) All conduit runs will be cleaned and swabbed before installation of electric cables. Crushed, obstructed or deformed conduit will not be accepted. The excavation for trenched conduit will be located at least 600 millimeters from the face of curb. All underground conduit will have a minimum depth of 750 millimeters below grade.

E. When multiple conduits in a common trench are required, no more than three (3) 75 millimeter or smaller conduits will be placed on a single horizontal level. Four (4) or more conduits will be installed on two (2) levels as directed by the Commissioner of CDOT".

SUB ITEM 5.2 CODE NO. ELECTRIC CABLE IN CONDUIT, TRIPLEX 2-1/C NO. 6 AND 1/C NO. 8. EP/HYPALON

Description: This work will consist of furnishing, installing, and testing multi-conductor triplexes power cable, complete with all splicing, identifications, and terminations, as specified herein, as shown and as directed by the Commissioner of CDOT. The cable will be installed in conduit.

Materials: Materials will be according to Bureau of Electricity (BOE) Specification 1440.

General Requirements: General requirements will be in accordance with Section 801 of the Standard Specifications, and in accordance with Bureau of Electricity Standards and the City of Chicago Electrical Code, except as modified herein.

Installation: Installation will be in accordance with Article 820.03 of the Standard Specifications, except for paragraph (b), which is revised to read as follows:

“(b) All cable will be installed with care to prevent damage to the installation of cable. The Contractor will check the cable for defects as it is being installed. Any defects found will be reported to the Commissioner of CDOT, and will be repaired to the satisfaction of the Commissioner of CDOT, or the cable replaced as directed by the Commissioner of CDOT.

Cable passing through manholes (or handholes) will be trained around the sides of the manhole into a permanent position on racks mounted on each manhole wall. Before racking and training new cables, the Contractor will rack and train all existing cables. Allowance will be made for cable expansion and contraction. Allowances must be made for cable contraction and expansion. Three meters of slack cable will be provided in handholes for all new installations.

The Contractor will be responsible for furnishing and installing cable racks and/or cable hooks for new and existing cables in all manholes and handholes as required to facilitate the cable installation.

Where cable runs continue from manhole to manhole without tapping within a light standard, they will be continuous without splices unless otherwise directed by the Commissioner of CDOT.

The cable installation will be colored coded so that each lid of all circuits may be easily identified and lighting units connected to the proper leg as indicated on the plans. The smallest conductor or equipment grounding conductor will always be color coded green.

All cable pulled into the street lighting control cabinets will be properly trained and will have sufficient slack provided for any rearrangement or future addition of equipment.

After a cable installation is completed, but before connections to apparatus are made, the insulation resistance of the cable will be measured by means of an approved 600 Volt MEGOHM tester. The installation resistance of any cable measured as specified will be not less than five megohms.

Splices above grade (such as in poles and junction boxes) will have waterproof sealant and a heat-shrinkable plastic cap. The cap will be of a size suitable for the splice and will have a factory-applied sealant within.

Additional seal of the splice will be assured by the application of sealant tape or the use of a sealant insert prior to the installation of the cap. Either method will be assured compatible with the cap sealant. Tape sealant will be applied in not less than one-half-lapped layer for a length at least 6.35 millimeters longer than the cap length and the tape will also be wrapped into the crotch of the splice. Insert sealant will be placed between the wires of the splice and will be positioned to line up flush or extend slightly past the open base of the cap.

Cable terminations or splices, where approved, will be made in a workmanlike manner. All connectors, insulating tapes, and related materials will be approved by the Commissioner of CDOT. Splices and terminations will be included in the installation of cable. Separate payment will be made.

When all cable installation has been completed in a manhole or handhole, the manhole or handhole will be cleared of all debris and left in broom clean condition”.

ITEMS 6 THROUGH 14: INSTALLATION OF STREET FURNITURE FIXTURES

Work under this item will be performed in accordance with the each Street Furniture fixture manufacturer’s applicable, requirements and specifications.

STREET FURNITURE ITEMS TO BE INSTALLED:

ITEM 6. BUS STOP SHELTERS

ITEM 7. MULTIPLE NEWSRACKS

ITEM 8. NEWSSTANDS

ITEM 9. BUS SUPERVISOR SHELTERS

ITEM 10. CAFE KIOSKS

ITEM 11. CITY INFORMATION PANELS

ITEM 12. SEWER SERVICE LINES INSTALLATION AND CONNECTIONS

All work for sewer service line installation and connections will be performed in accordance with CDOT’s Regulation for Openings, Construction and Repair in the Public Way and Chicago Department of Sewers’ specification for sewer installations.

ITEM 13. WATER SERVICE LINE INSTALLATION AND CONNECTIONS

All work for water service line installation and connection will be performed in accordance with Chicago Department of Transportation's (CDOT)'s Regulation for Openings, Construction and Repair in the Public Way and Chicago Department of Water's Specifications for watermain installations.

ITEM 14. ACCESSIBILITY FOR PERSONS WITH DISABILITIES

The contractor will be responsible for having all Street Furniture Fixtures accessible to persons with disabilities as required by CDOT Standards and in compliance with the Illinois Accessibility Code and the American with Disabilities Act. All work performed by the Contractor will be approved prior to construction and after construction to ensure compliance. The Bureau of Streets of CDOT will be responsible for work approval and compliance.

ITEM 15. INSTALLATION OF TELEPHONE SERVICE LINE

Contractor must submit for the Commissioner of CDOT's review and approval a utility service plan identifying procedures and locations.

ITEM 16. PUBLIC WAY RESTORATIONS

The Contractor will be responsible for restoring the Public Way to its original conditions as required in the CDOT's Chicago Department of Transportation's Regulation for Openings, Construction and Repair in the Public Way.

ITEM 17. PERMITS AND LICENSES

1. Whenever the work under this Contract requires the obtaining of permits from the City of Chicago or other public authorities, triplicate copies of such permits are furnished to the City by the Contractor before work covered hereby is started. **NO WORK IS ALLOWED TO PROCEED BEFORE SUCH PERMITS ARE OBTAINED.**
2. Permits required from the Metropolitan Water Reclamation District of Greater Chicago, the Illinois Environmental Protection Agency, IDOT Division of Water Resources, the U.S. Coast Guard and the U.S. Corps of Engineers will be obtained by the City.
3. **Permits and Fees:** The special use of, or removal, alternation or replacement of certain City-owned facilities and appurtenances such as traffic signs, parking meters, trees, sewers, hydrants, bridges and viaducts which are required for the Contractor to perform its Work, are subject to all applicable Municipal Ordinances. It is the Contractor's responsibility to obtain all the necessary permits and pay the associated fees. Copies of such permits must be furnished to the City by the Contractor before the Work covered is started. Information with regard to the above may be obtained by contacting the appropriate City departments.

4. If a highway permit bond was posted, it must remain in effect for at least five years from the date of permit issuance.

ITEM 18. VAULTED SIDEWALK

If the location selected by the Commissioner of CDOT for the installation of the street furniture fixtures is a vaulted sidewalk, the Contractor will be required to install the fixture by one of the methods discussed below:

Method No. 1.

The Contractor will be responsible for determining the structural adequacy of the vaulted sidewalk. If the vaulted sidewalk is structurally adequate, the Contractor will install the fixture in accordance with manufactures specifications.

Method No. 2

If the existing vaulted sidewalk is determined to be inadequate, it will be the responsibility of the Contractor to perform all repairs and rehabilitation of the slab, walls, cross beams and all other inadequate components of the vaulted sidewalk. After the vaulted sidewalk has been restored and is structurally adequate, the Contractor will install the street fixture in accordance with manufactures specifications.

Method No. 3.

If the vaulted sidewalk cannot be adequately reconstructed/restored for the installation of the proposed street fixture, the Contractor will be responsible for removing and disposing of the area of the affected vaulted sidewalk, cross beams and other vaulted sidewalk components. The Contractor will also be required to saw cut between the vaulted sidewalk to be left in place and vaulted sidewalk to be restored. All materials removed will be disposed of in accordance with Section 202.03 of the Standard Specifications.

During the vaulted sidewalk removal, the Contractor will provide all bracing and shoring required to shore up existing walls and slabs so as to ensure that no damage is done to the adjoining infrastructure.

After the vaulted sidewalk is removed, the Contractor will construct all partition/ retaining walls prior to backfilling the vaulted sidewalk area. The vaulted sidewalk area will be backfilled up to the required subgrade level with fine aggregates meeting the gradation requirement of FA6 of Section 703 of the Standard Specification. The material will be placed in 12 inch layers and each layer will be compacted to 95 percent of maximum density as determined by AASHTO T-99.

After backfilling the vaulted sidewalk area to the required subgrade level, the Contractor will place PCC foundations and slabs in accordance with Item 3: Portland Cement Concrete Foundations and Slabs.

After the PCC is cured, the Contractor will install street furniture fixture in accordance with manufactures specifications.

The Contractor will be responsible for repairing, restoring and/or reconstructing all adjoining infrastructure damaged by the Contractor. The adjoining infrastructure may include but not limited to: waterproofing membrane, cross beams, sidewalk slabs, walls, curbs, street pavements, private property, etc.

The Contractor will be responsible for repairing, restoring and/or reconstructing all adjoining infrastructure damaged by the Contractor. The adjoining infrastructure may include but not limited to: waterproofing membrane, cross beams, sidewalk slabs, walls, curbs, street pavements, private property, etc.

EXHIBIT 9
Average Installation Costs of Street Furniture]

<u>Type of Street Furniture</u>	<u>Average Cost of Installation*</u>
Bus Stop Shelter	\$12,500
Multiple Newsrack	\$ 800
Newsstand	\$12,500
Café Kiosk	\$50,000
Bus Supervisor Shelter	\$13,000
CIP	\$ 9,000

***All costs to be increased by the Consumer Price Index every year, beginning in 2003.**

EXHIBIT 10
Prevailing Wage Rates

12913600.29 02939431

Cook County Prevailing Wage for June 2002

Trade Name	RG	TYP	C	Base	FRMAN	*M-F>8	OSA	OSH	H/W	Pensn	Vac	Trng
ASBESTOS ABT-GEN	ALL			26.800	27.550	1.5	1.5	2.0	3.450	2.650	0.000	0.170
ASBESTOS ABT-MEC	BLD			23.300	24.800	1.5	1.5	2.0	3.640	5.520	0.000	0.000
BOILERMAKER	BLD			33.190	35.030	2.0	2.0	2.0	3.700	4.650	0.000	0.150
BRICK MASON	BLD			29.300	31.300	1.5	1.5	2.0	4.300	4.580	0.000	0.120
CARPENTER	ALL			31.970	33.470	1.5	1.5	2.0	4.710	3.510	0.000	0.440
CEMENT MASON	ALL			30.000	31.000	2.0	1.5	2.0	4.880	3.750	0.000	0.000
CERAMIC TILE FNSHER	ALL			23.300	0.000	2.0	1.5	2.0	3.500	3.700	0.000	0.210
COMM. ELECT.	BLD			28.000	29.500	1.5	1.5	2.0	3.500	4.830	0.000	0.700
ELECTRIC PWR EQMT OP	ALL			31.300	36.460	1.5	1.5	2.0	4.150	7.100	0.000	0.160
ELECTRIC PWR GRNDMAN	ALL			24.410	36.460	1.5	1.5	2.0	3.240	5.520	0.000	0.120
ELECTRIC PWR LINEMAN	ALL			31.300	36.460	1.5	1.5	2.0	4.150	7.100	0.000	0.160
ELECTRICIAN	ALL			31.650	33.650	1.5	1.5	2.0	6.000	5.800	0.000	0.600
ELEVATOR CONSTRUCTOR	BLD			33.585	37.780	2.0	2.0	2.0	4.425	2.610	2.020	0.000
FENCE ERECTOR	ALL			21.840	23.090	1.5	1.5	2.0	4.300	5.120	0.000	0.000
GLAZIER	BLD			26.800	27.800	1.5	2.0	2.0	4.340	7.550	0.000	0.200
HT/FROST INSULATOR	BLD			28.250	30.000	1.5	1.5	2.0	4.980	7.060	0.000	0.230
IRON WORKER	ALL			31.250	32.750	2.0	2.0	2.0	5.560	9.190	0.000	0.220
LABORER	ALL			26.650	27.400	1.5	1.5	2.0	3.450	2.650	0.000	0.170
LATHER	BLD			31.970	33.470	1.5	1.5	2.0	4.710	3.510	0.000	0.440
MACHINIST	BLD			30.610	32.360	2.0	2.0	2.0	3.200	2.600	2.110	0.000
MARBLE FINISHERS	ALL			23.000	0.000	1.5	1.5	2.0	3.600	3.800	0.000	0.240
MARBLE MASON	BLD			26.780	28.280	1.5	1.5	2.0	4.300	6.600	0.000	0.230
MILLWRIGHT	ALL			31.970	33.470	1.5	1.5	2.0	4.710	3.510	0.000	0.440
OPERATING ENGINEER	BLD 1			33.850	37.850	2.0	2.0	2.0	5.400	4.250	1.700	0.500
OPERATING ENGINEER	BLD 2			32.550	37.850	2.0	2.0	2.0	5.400	4.250	1.700	0.500
OPERATING ENGINEER	BLD 3			30.000	37.850	2.0	2.0	2.0	5.400	4.250	1.700	0.500
OPERATING ENGINEER	BLD 4			28.250	37.850	2.0	2.0	2.0	5.400	4.250	1.700	0.500
OPERATING ENGINEER	FLT 1			36.300	36.300	1.5	1.5	2.0	5.150	4.000	1.600	0.000
OPERATING ENGINEER	FLT 2			34.800	36.300	1.5	1.5	2.0	5.150	4.000	1.600	0.000
OPERATING ENGINEER	FLT 3			31.000	36.300	1.5	1.5	2.0	5.150	4.000	1.600	0.000
OPERATING ENGINEER	FLT 4			25.750	36.300	1.5	1.5	2.0	5.150	4.000	1.600	0.000
OPERATING ENGINEER	HWY 1			32.050	36.050	1.5	1.5	2.0	5.400	4.250	1.700	0.500
OPERATING ENGINEER	HWY 2			31.500	36.050	1.5	1.5	2.0	5.400	4.250	1.700	0.500
OPERATING ENGINEER	HWY 3			29.450	36.050	1.5	1.5	2.0	5.400	4.250	1.700	0.500
OPERATING ENGINEER	HWY 4			28.050	36.050	1.5	1.5	2.0	5.400	4.250	1.700	0.500
OPERATING ENGINEER	HWY 5			26.850	36.050	1.5	1.5	2.0	5.400	4.250	1.700	0.500
ORNAMNTL IRON WORKER	ALL			28.850	30.350	2.0	2.0	2.0	4.300	7.370	0.000	0.000
PAINTER	ALL			28.600	32.180	1.5	1.5	1.5	4.000	4.200	0.000	0.240
PAINTER SIGNS	BLD			24.540	27.550	1.5	1.5	1.5	2.860	1.960	0.000	0.000
PILEDRIIVER	ALL			31.970	33.470	1.5	1.5	2.0	4.710	3.510	0.000	0.440
PIPEFITTER	BLD			33.000	35.000	1.5	1.5	2.0	4.000	4.550	0.000	0.000
PLASTERER	BLD			28.440	29.440	1.5	1.5	2.0	3.750	4.250	0.000	0.400
PLUMBER	BLD			33.750	35.750	1.5	1.5	2.0	4.250	2.840	0.000	0.000
ROOFER	BLD			30.000	32.000	1.5	1.5	2.0	3.750	2.330	0.000	0.320
SHEETMETAL WORKER	BLD			30.730	33.190	1.5	1.5	2.0	4.310	6.790	0.000	0.490
SIGN HANGER	BLD			21.930	22.780	1.5	1.5	2.0	3.580	1.740	0.440	0.000
SPRINKLER FITTER	BLD			32.420	33.920	2.0	2.0	2.0	4.000	4.900	0.000	0.300
STEEL ERECTOR	ALL			30.000	31.500	2.0	2.0	2.0	5.060	8.740	0.000	0.220
STONE MASON	BLD			29.300	31.300	1.5	1.5	2.0	4.300	4.580	0.000	0.120
TERRAZZO MASON	BLD			27.370	28.870	2.0	1.5	2.0	4.300	5.050	0.000	0.160
TILE MASON	BLD			28.420	30.420	2.0	1.5	2.0	3.500	4.350	0.000	0.400
TRAFFIC SAFETY WRKR	HWY			19.650	21.150	1.5	1.5	1.5	2.100	0.900	0.000	0.000
TRUCK DRIVER	E ALL 1			24.700	25.350	1.5	1.5	2.0	4.000	2.800	0.000	0.000
TRUCK DRIVER	E ALL 2			24.950	25.350	1.5	1.5	2.0	4.000	2.800	0.000	0.000

TRUCK DRIVER	E	ALL	3	25.150	25.350	1.5	1.5	2.0	4.000	2.800	0.000	0.000
TRUCK DRIVER	E	ALL	4	25.350	25.350	1.5	1.5	2.0	4.000	2.800	0.000	0.000
TRUCK DRIVER	W	ALL	1	25.300	25.850	1.5	1.5	2.0	3.950	2.750	0.000	0.000
TRUCK DRIVER	W	ALL	2	25.450	25.850	1.5	1.5	2.0	3.950	2.750	0.000	0.000
TRUCK DRIVER	W	ALL	3	25.650	25.850	1.5	1.5	2.0	3.950	2.750	0.000	0.000
TRUCK DRIVER	W	ALL	4	25.850	25.850	1.5	1.5	2.0	3.950	2.750	0.000	0.000
TUCKPOINTER	BLD			29.650	30.650	1.5	1.5	2.0	3.660	4.500	0.000	0.260

Legend:

M-F>8 (Overtime is required for any hour greater than 8 worked each day, Monday through Friday.)
 OSA (Overtime is required for every hour worked on Saturday)
 OSH (Overtime is required for every hour worked on Sunday and Holidays)
 H/W (Health & Welfare Insurance)
 Pensn (Pension)
 Vac (Vacation)
 Trng (Training)

Explanations

COOK COUNTY

TRUCK DRIVERS (WEST) - That part of the county West of Barrington Road.

The following list is considered as those days for which holiday rates of wages for work performed apply: New Years Day, Memorial/Decoration Day, Fourth of July, Labor Day, Veterans Day, Thanksgiving Day, Christmas Day. Generally, any of these holidays which fall on a Sunday is celebrated on the following Monday. This then makes work performed on that Monday payable at the appropriate overtime rate for holiday pay. Common practice in a given local may alter certain days of celebration such as the day after Thanksgiving for Veterans Day. If in doubt, please check with IDOL.

EXPLANATION OF CLASSES

ASBESTOS - GENERAL - removal of asbestos material from any place in a building, including mechanical systems where those mechanical systems are to be removed. This includes the removal of asbestos materials from ductwork or pipes in a building when the building is to be demolished at the time or at some close future date.

ASBESTOS - MECHANICAL - removal of asbestos material from mechanical systems, such as pipes, ducts, and boilers, where the mechanical systems are to remain.

COMMUNICATIONS ELECTRICIAN - Installation, operation, inspection, maintenance, repair and service of radio, television, recording, voice sound vision production and reproduction, telephone and telephone interconnect, facsimile, data apparatus, coaxial, fibre optic and wireless equipment, appliances and systems used for the transmission and reception of signals of any nature, business, domestic, commercial, education, entertainment, and residential purposes, including but not limited to, communication and telephone, electronic and sound equipment, fibre optic and data communication systems, and the performance of any task directly related to such installation or service whether at new or existing sites, such tasks to include the placing of wire and cable and electrical power conduit or other raceway work within the equipment room and pulling wire and/or cable

through conduit and the installation of any incidental conduit, such that the employees covered hereby can complete any job in full.

TRAFFIC SAFETY - work associated with barricades, hoses and drums used to reduce lane usage on highway work, the installation and removal of temporary lane markings, and the installation and removal of temporary road signs.

TRUCK DRIVER - BUILDING, HEAVY AND HIGHWAY CONSTRUCTION - EAST & WEST

Class 1. Two or three Axle Trucks. A-frame Truck when used for transportation purposes; Air Compressors and Welding Machines, including those pulled by cars, pick-up trucks and tractors; Ambulances; Batch Gate Lockers; Batch Hopperman; Car and Truck Washers; Carry-alls; Fork Lifts and Hoisters; Helpers; Mechanics Helpers and Greasers; Oil Distributors 2-man operation; Pavement Breakers; Pole Trailer, up to 40 feet; Power Mower Tractors; Self-propelled Chip Spreader; Skipman; Slurry Trucks, 2-man operation; Slurry Truck Conveyor Operation, 2 or 3 man; TEamsters Unskilled dumpman; and Truck Drivers hauling warning lights, barricades, and portable toilets on the job site.

Class 2. Four axle trucks; Dump Crets and Adgetors under 7 yards; Dumpsters, Track Trucks, Euclids, Hug Bottom Dump Turnapulls or Turnatrailers when pulling other than self-loading equipment or similar equipment under 16 cubic yards; Mixer Trucks under 7 yards; Ready-mix Plant Hopper Operator, and Winch Trucks, 2 Axles.

Class 3. Five axle trucks; Dump Crets and Adgetors 7 yards and over; Dumpsters, Track Trucks, Euclids, Hug Bottom Dump Turnatrailers or turnapulls when pulling other than self-loading equipment or similar equipment over 16 cubic yards; Explosives and/or Fission Material Trucks; Mixer Trucks 7 yards or over; Mobile Cranes while in transit; Oil Distributors, 1-man operation; Pole Trailer, over 40 feet; Pole and Expandable Trailers hauling material over 50 feet long; Slurry trucks, 1-man operation; Winch trucks, 3 axles or more; Mechanic--Truck Welder and Truck Painter.

Class 4. Six axle trucks; Dual-purpose vehicles, such as mounted crane trucks with hoist and accessories; Foreman; Master Mechanic; Self-loading equipment like P.B. and trucks with scoops on the front.

OPERATING ENGINEERS - BUILDING

Class 1. Mechanic; Asphalt Plant; Asphalt Spreader; Autograde; Backhoes with Caisson attachment; Batch Plant; Benoto; Boiler and Throttle Valve; Caisson Rigs; Central Redi-Mix Plant; Combination Back Hoe Front End-loader Machine; Compressor and Throttle Valve; Concrete Breaker (Truck Mounted); Concrete Conveyor; Concrete Paver; Concrete Placer; Concrete Placing Boom; Concrete Pump (Truck Mounted); Concrete Tower; Cranes, All; Cranes, Hammerhead; Cranes, (GCI and similar Type); Creter Crane; Crusher, Stone, etc.; Derricks, All; Derricks, Traveling; Formless Curb and Gutter Machine; Grader, Elevating; Grouting Machines; Highlift Shovels or Front Endloader 2-1/4 yd. and over; Hoists, Elevators, outside type rack and pinion and similar machines; Hoists, one, two and three Drum; Hoists, Two Tugger One Floor; Hydraulic Backhoes; Hydraulic Boom Trucks; Hydro Vac (and similar equipment); Locomotives, All; Motor Patrol; Pile Drivers and Skid Rig; Post Hole Digger; Pre-Stress Machine; Pump

Cretes Dual Ram; Pump Cretes; Squeeze Cretes-screw Type Pumps; Raised and Blind Hole Drill; Roto Mill Grinder; Scoops - Tractor Drawn; Slip-form Paver; Straddle Buggies; Tournapull; Tractor with Boom and Side Boom; Trenching Machines.

Class 2. Bobcat (over 3/4 cu. yd.); Boilers; Brick Forklift; Broom, All Power Propelled; Bulldozers; Concrete Mixer (Two Bag and Over); Conveyor, Portable; Forklift Trucks; Greaser Engineer; Highlift Shovels or Front Endloaders under 2-1/4 yd.; Hoists, Automatic; Hoists, inside Freight Elevators; Hoists, Sewer Dragging Machine; Hoists, Tugger Single Drum; Laser Screed; Rock Drill (self-propelled); Rock Drill (truck mounted); Rollers, All; Steam Generators; Tractors, All; Tractor Drawn Vibratory Roller; Winch Trucks with "A" Frame.

Class 3. Air Compressor; Combination - Small Equipment Operator; Generators; Heaters, Mechanical; Hoists, Inside Elevators - (Rheostat Manual Controlled); Hydraulic Power Units (Pile Driving, Extracting, and Drilling); Pumps, over 3" (1 to 3 not to exceed a total of 300 ft.); Pumps, Well Points; Welding Machines (2 through 5); Winches, 4 small Electric Drill Winches; Bobcat (up to and including 3/4 cu. yd.).

Class 4. Bobcats and/or other Skid Steer Loaders; Oilers; and Brick Forklift.

OPERATING ENGINEERS - FLOATING

Class 1. Craft foreman (Master Mechanic), diver/wet tender, engineer (hydraulic dredge).

Class 2. Crane/backhoe operator, mechanic/welder, assistant engineer (hydraulic dredge), leverman (hydraulic dredge), and diver tender.

Class 3. Deck equipment operator (machineryman), maintenance of crane (over 50 ton capacity) or backhoe (96,000 pounds or more), tug/launch operator, loader, dozer and like equipment on barge, breakwater wall, slip/dock or scow, deck machinery, etc.

Class 4. Deck equipment operator (machineryman/fireman), (4 equipment units or more) and crane maintenance 50 ton capacity and under or backhoe weighing 96,000 pounds or less, assistant tug operator.

OPERATING ENGINEERS - HEAVY AND HIGHWAY CONSTRUCTION

Class 1. Craft Foreman; Asphalt Plant; Asphalt Heater and Planer Combination; Asphalt Heater Scarfire; Asphalt Spreader; Autograder/GOMACO or other similar type machines; ABG Paver; Backhoes with Caisson attachment; Ballast Regulator; Belt Loader; Caisson Rigs; Car Dumper; Central Redi-Mix Plant; Combination Backhoe Front Endloader Machine, (1 cu. yd. Backhoe Bucket or over or with attachments); Concrete Breaker (Truck Mounted); Concrete Conveyor; Concrete Paver over 27E cu. ft.; Concrete Placer; Concrete Tube Float; Cranes, all attachments; Cranes, Hammerhead, Linden, Peco & Machines of a like nature; Crete Crane; Crusher, Stone, etc.; Derricks, All; Derrick Boats; Derricks, Traveling; Dowell machine with Air Compressor; Dredges; Field Mechanic-Welder; Formless Curb and Gutter Machine; Gradall and Machines of a like nature; Grader, Elevating; Grader, Motor Grader, Motor Patrol, Auto Patrol, Form Grader, Pull Grader, Subgrader; Guard Rail Post Driver Mounted; Hoists, One, Two and Three Drum; Hydraulic Backhoes; Backhoes with shear attachments; Mucking Machine; Pile Drivers and Skid Rig;

Pre-Stress Machine; Pump Cretes Dual Ram; Rock Drill - Crawler or Skid Rig; Rock Drill - Truck Mounted; Roto Mill Grinder; Slip-Form Paver; Soil Test Drill Rig (Truck Mounted); Straddle Buggies; Hydraulic Telescoping Form (Tunnel); Tractor Drawn Belt Loader (with attached pusher - two engineers); Tractor with Boom; Tractaire with Attachments; Trenching Machine; Truck Mounted Concrete Pump with Boom; Raised or Blind Hole; Drills (Tunnel Shaft); Underground Boring and/or Mining Machines; Wheel Excavator; Widener (APSCO).

Class 2. Batch Plant; Bituminous Mixer; Boiler and Throttle Valve; Bulldozers; Car Loader Trailing Conveyors; Combination Backhoe Front Endloader Machine (less than 1 cu. yd. Backhoe Bucket or over or with attachments); Compressor and Throttle Valve; Compressor, Common Receiver (3); Concrete Breaker or Hydro Hammer; Concrete Grinding Machine; Concrete Mixer or Paver 7S Series to and including 27 cu. ft.; Concrete Spreader; Concrete Curing Machine, Burlap Machine, Belting Machine and Sealing Machine; Concrete Wheel Saw; Conveyor Muck Cars (Haglund or Similar Type); Drills, All; Finishing Machine - Concrete; Greaser Engine; Highlift Shovels or Front Endloader; Hoist - Sewer Dragging Machine; Hydraulic Boom Trucks (All Attachments); Hydro-Blaster; All Locomotives, Dinky; Pump Cretes; Squeeze Cretes-Screw Type Pumps, Gypsum Bulker and Pump; Roller, Asphalt; Rotary Snow Plows; Rototiller, Seaman, etc., self-propelled; Scoops - Tractor Drawn; Self-Propelled Compactor; Spreader - Chip - Stone, etc.; Scraper; Scraper - Prime Mover in Tandem (Regardless of Size); Tank Car Heater; Tractors, Push, Pulling Sheeps Foot, Disc, Compactor, etc.; Tug Boats.

Class 3. Boilers; Brooms, All Power Propelled; Cement Supply Tender; Compressor, Common Receiver (2); Concrete Mixer (Two Bag and Over); Conveyor, Portable; Farm-Type Tractors Used for Mowing, Seeding, etc.; Fireman on Boilers; Forklift Trucks; Grouting Machine; Hoists, Automatic; Hoists, All Elevators; Hoists, Tugger Single Drum; Jeep Diggers; Pipe Jacking Machines; Post-Hole Digger; Power Saw, Concrete Power Driven; Pug Mills; Rollers, other than asphalt; Seed and Straw Blower; Steam Generators; Stump Machine; Winch Trucks with "A" Frame; Work Boats; Tamper - Form-Motor Driven.

Class 4. Air Compressor; Combination - Small Equipment Operator; Directional Boring Machine; Generators; Heaters, Mechanical; Hydraulic Power Unit (Pile Driving, Extracting, or Drilling); Hydro-Blaster; Light Plants, All (1 through 5); Pumps, over 3" (1 to 3 not to exceed a total of 300 ft.); Pumps, Well Points; Tractaire; Welding Machines (2 through 5); Winches, 4 Small Electric Drill Winches.

Class 5. Bobcats (all); Brick FForklift Oilers.

Other Classifications of Work:

For definitions of classifications not otherwise set out, the Department generally has on file such definitions which are available. If there is no such definition on file, the Bureau of Labor Statistics SIC list will be used. If a task to be performed is not subject to one of the classifications of pay set out, the Department will upon being contacted state which neighboring county has such a classification and provide such rate, such rate being deemed to exist by reference in this document. Further, if no such neighboring county rate applies to the task, the Department shall undertake a special determination, such special determination being

then deemed to have existed under this determination. If a project requires these, or any classification not listed, please contact IDOL at 618/993-7271 for wage rates or clarifications.

LANDSCAPING

Landscaping work falls under the existing classifications for laborer, operating engineer and truck driver. The work performed by landscape plantsman and landscape laborer is covered by the existing classification of laborer. The work performed by landscape operators (regardless of equipment used or its size) is covered by the classifications of operating engineer. The work performed by landscape truck drivers (regardless of size of truck driven) is covered by the classifications of truck driver.

EXHIBIT 11
Contractor's Advertising Policy



Ms. Amy Degnan
Assistant to the Mayor
City Hall
121 North La Salle
Chicago, Illinois 60602

Dear Ms. Degnan:

Pursuant to your request we provide JCDecaux Chicago LLC's ("JCD") street furniture advertising policy:

1. Outside the Central Business District JCD will limit alcohol advertising to locations that are not within a 150 foot radius of a school up through the level of high school, houses of worship or playgrounds. Inside the Central Business District JCD will apply the same standard to the extent it is reasonable to do so.

2. JCD shall not permit advertising that is legally obscene or sexually explicit (depicting nudity (male or female genitals, pubic areas, or buttocks with less than a fully opaque covering, female breasts with less than a fully opaque covering on any part of the areolae or nipples, or the covered genitals in a discernibly turgid or other recognizable state) or sexual intercourse or other sexual acts);

3. JCD shall not permit advertising that portrays graphic violence, such as through the depiction of human or animal bodies, body parts or fetuses in states of mutilation, dismemberment, disfigurement or decomposition; and

4. JCD shall not permit advertising that is directed to inciting or producing imminent lawless action and likely to produce such action, including, without limitation, unlawful action based on a person's race,

Street Furniture:

Amsterdam
Antwerp
Barcelona
Birmingham
Bratislava
Bremen
Brussels
Cologne
Copenhagen
Dresden
Gothenburg
Hamburg
Helsinki
The Hague
Leipzig
Lisbon
London
Luxemburg
Lyon
Madrid
Manchester
Munich
Paris
Prague
San Francisco
Stockholm
Stuttgart
Sydney

JCDecaux

color, sex, age, religion, disability, national origin, ancestry, sexual orientation, marital or parental status, military discharge status, or sources of income.

Sincerely,

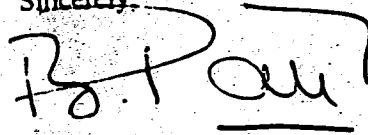
A handwritten signature in black ink, appearing to read "B. Parisot". The signature is written in a cursive style with a large initial "B" and a long horizontal stroke at the end.

Bernard Parisot
Chief Executive Officer

EXHIBIT 12
Form of Parent Guarantees

GUARANTY

THIS GUARANTY (the "Guaranty") is given as of the ___ day of June, 2002 by JCDecaux North America Inc., a Delaware corporation ("Guarantor"), to the City of Chicago, a municipal corporation (hereinafter "Beneficiary").

RECITALS:

WHEREAS, JCDecaux Chicago LLC, an Illinois limited liability company ("Affiliate"), is a wholly-owned subsidiary of Guarantor;

WHEREAS, Affiliate and Beneficiary have entered into a Coordinated Street Furniture Program Agreement (the "Agreement"), dated as of June ___, 2002; and

WHEREAS, it is in the best interest of the Guarantor to execute this Guaranty and Guarantor will derive substantial benefits from the Agreement, and Guarantor has agreed to provide this Guaranty to induce Beneficiary to enter into the Agreement.

NOW, THEREFORE, in consideration of the foregoing, and for other good and valuable consideration, the receipt and adequacy of which are hereby acknowledged, and as a material inducement to Beneficiary to enter into the Agreement, Guarantor agrees as follows:

1. Guaranty of Payment and Performance. Guarantor hereby irrevocably and unconditionally guarantees to Beneficiary the complete and timely payment to Beneficiary of Contractor Fees and all other financial obligations such as payment of liquidated damages, if applicable, as described in the Agreement which Affiliate is required to pay pursuant to the Agreement (the "Fee Obligations"). In the event that Affiliate fails to pay its Fee Obligations,

Guarantor will promptly and fully make payments to satisfy the Fee Obligations in the place of Affiliate. Except as set forth above, nothing contained herein shall be construed as obligating Guarantor to pay or perform any obligations of Affiliate other than the Fee Obligations.

2. Guarantor's Fee Obligations Are Absolute.

(a) This Guaranty is an absolute, irrevocable and unconditional guaranty of payment and performance and is not a guaranty of collection. Guarantor shall be liable for the payment of the Fee Obligations, as set forth in this Guaranty, as a primary obligor. This Guaranty shall be effective as a waiver of, and Guarantor hereby expressly waives, any and all rights to which Guarantor may otherwise have been entitled under any suretyship laws in effect from time to time; including any right or privilege, whether existing under statute, at law or in equity, to require Beneficiary to take prior recourse or proceedings against any collateral, security or person whatsoever.

(b) Guarantor hereby agrees that in the event of (i) an event of default by Affiliate under the Agreement; (ii) the dissolution or insolvency of Guarantor; or (iii) the institution of any proceeding by or against Guarantor in bankruptcy or for a reorganization or an arrangement with creditors, or for the appointment of a receiver, trustee or custodian for any of them or for any of its properties; provided if such proceeding is instituted against Guarantor, then such proceeding shall not cause the Fee Obligations to be immediately due and payable if such proceeding is dismissed within one hundred twenty (120) days of filing; if not dismissed within one hundred and twenty (120) days of filing then the Fee Obligations, for purposes of this Guaranty, shall be deemed immediately due and payable at the election of Beneficiary under its rights in the Agreement, and Guarantor shall, on demand and without presentment, protest,

notice of protest, further notice of nonpayment or of dishonor or of default or nonperformance, or notice of acceleration or of intent to, or any other notice whatsoever, without any notice having been given to Guarantor previous to such demand of the acceptance by Beneficiary of this Guaranty, and without any notice having been given to Guarantor previous to such demand of the creating or incurring of such indebtedness or of such obligation to perform, all such notices being hereby waived by Guarantor, pay the Fee Obligations to Beneficiary, and it shall not be necessary for Beneficiary, in order to enforce such payment or performance by Guarantor, first to institute suit or pursue or exhaust any rights or remedies against Affiliate or any other guarantor of the Fee Obligations for payment, or to institute suit or pursue or exhaust any rights or remedies against Affiliate, and any other Guarantor or surety of the Fee Obligations, or to enforce any rights against any security that shall ever have been given to secure the Fee Obligations, or to join Affiliate, or any other Guarantor or surety for the payment of the Fee Obligations or any part thereof in any action to enforce this Guaranty, or to resort to any other means of obtaining payment of the Fee Obligations.

(c) Suit may be brought or demand may be made against the Guarantor, and any other obligor under any other guaranty covering all or any part of the Fee Obligations without impairing the rights of Beneficiary against Guarantor, or any other Guarantor or surety.

3. Waivers.

(a) Except to the extent the Fee Obligations have been satisfied, Guarantor hereby agrees that neither Beneficiary's rights or remedies nor Guarantor's obligations under the terms of this Guaranty shall be released, diminished, impaired, reduced or affected by any one or

more of the following events, actions, facts, or circumstances, and the liability of Guarantor under this Guaranty shall be absolute and unconditional irrespective of:

(i) any claim or defense that this Guaranty was made without consideration or is not supported by adequate consideration;

(ii) the taking or accepting of any other security or guaranty for, or right of recourse with respect to, any or all of the Fee Obligations;

(iii) the availability to Guarantor of any exemption or defense under applicable law;

(iv) any release, surrender, abandonment, exchange, alteration, sale or other disposition, subordination, deterioration, waste, failure to protect or preserve, impairment, or loss of, or any failure to create or perfect any lien or security interest with respect to, or any other dealings with, any collateral or security at any time existing or purported, believed or expected to exist in connection with any or all of the Fee Obligations, including any impairment of Guarantor's recourse against any person or collateral;

(v) whether express or by operation of law, any partial release of the liability of Guarantor hereunder, or if one or more other guaranties are now or hereafter obtained by Beneficiary from any other guarantor covering all or any part of the Fee Obligations, any complete or partial release of any other guarantor under any such other guaranty, or any complete or partial release of or settlement with Affiliate;

(vi) the insolvency, bankruptcy, dissolution, liquidation, termination, receivership, reorganization, merger, consolidation, change of form, structure or ownership, sale

of all assets, or lack of corporate, partnership or other power of Affiliate or any other guarantor or surety at any time liable for the payment or performance of any or all of the Fee Obligations;

(vii) either with or without notice to or consent of Guarantor: any renewal, extension, modification or rearrangement of the terms of any or all of the Fee Obligations and/or the Agreement, or any waiver, termination, or release of, or consent to departure from, the Agreement or any other guaranty of any or all of the Fee Obligations, or any adjustment, indulgence, forbearance, or compromise that may be granted from time to time by Beneficiary to Affiliate, Guarantor, and/or any other guarantor or surety liable for all or any portion of the Fee Obligations;

(viii) any neglect, lack of diligence, delay, omission, forbearance, failure, or refusal of Beneficiary to take or prosecute (or in taking or prosecuting) any action for the collection or enforcement of any of the Fee Obligations, or to take or prosecute any action upon any security therefor, or to exercise (or in exercising) any other right or power with respect to any security therefor, or to take or prosecute (or in taking or prosecuting) any action in connection with the Agreement, or any failure to sell or otherwise dispose of in a commercially reasonable manner any collateral securing any or all of the Fee Obligations;

(ix) any failure of Beneficiary to notify Guarantor of any creation, renewal, extension, rearrangement, modification, supplement, subordination, or assignment of the Fee Obligations or any part thereof, or of the Agreement, or of any release of or change in any security, or of any other action taken or refrained from being taken by Beneficiary against Affiliate or any other guarantor, or any security or other recourse, or of any new agreement between Beneficiary and Affiliate or between Beneficiary and any other guarantor, it being

understood that, except with respect to the requirements for the service of process required to commence a lawsuit against Guarantor, Beneficiary shall not be required to give Guarantor any notice of any kind under any circumstances with respect to or in connection with the Fee Obligations, any and all rights to notice Guarantor may have otherwise had being hereby waived by Guarantor, and the Guarantor shall be responsible for obtaining for itself information regarding Affiliate, including, but not limited to, any changes in the business or financial condition of Affiliate, and Guarantor acknowledges and agrees that Beneficiary shall have no duty to notify Guarantor of any information which Beneficiary may have concerning Affiliate;

(x) if any requirement for any reason that Beneficiary is required to refund any payment by Affiliate to any other party liable for the payment or performance of any or all of the Fee Obligations or pay the amount thereof to someone else;

(xi) the existence of any claim, counterclaim, set-off, recoupment, reduction or defense based upon any claim or other right that Guarantor may at any time have against Affiliate, Beneficiary, or any other person, whether or not arising in connection with this Guaranty or the Agreement;

(xii) the unenforceability of all or any part of the Fee Obligations against Affiliate, whether because the Fee Obligations exceed the amount permitted by law or violate any usury law, or because the act of creating the Fee Obligations, or any part thereof, is ultra vires, or because the officers or persons creating same acted in excess of its authority, or because of a lack of validity or enforceability of or defect or deficiency in the Agreement or because Affiliate has any valid defense, claim or offset with respect thereto, or because Affiliate's obligation ceases to exist by operation of law, or because of any other reason or circumstance, it

being agreed that Guarantor shall remain liable hereon regardless of whether Affiliate, or any other person be found not liable on the Fee Obligations, or any part thereof, for any reason (and regardless of any joinder of Affiliate or any other party in any action to obtain payment or performance of any or all of the Fee Obligations); or

(xiii) any order, ruling or plan of reorganization emanating from proceedings under Title 11 of the United States Code with respect to Affiliate, or any other person, including any extension, reduction, composition, or other alteration of the Fee Obligations, whether or not consented to Beneficiary.

(b) Guarantor hereby waives (i) notice of acceptance of this Guaranty; (ii) notice of any advances made by Beneficiary in connection with the Agreement; (iii) notice of any waiver, amendment, modification, postponement, release, renewal, extension, accrual or termination of any of the Fee Obligations or the Agreement; (iv) notice of the reliance of Beneficiary upon this Guaranty; (v) notice of the occurrence, existence or continuance of any event of default, or failure of payment or performance under this Agreement; (vi) demand for payment, diligence, presentment, filing of claims with a court in the event of receivership or bankruptcy of the Affiliate, protest or notice with respect to the Fee Obligations, and all demands whatsoever; and (vii) any other notice, demand, protest or formality which would otherwise be legally required to charge Guarantor with liability hereunder; and Guarantor covenants and agrees that this Guaranty will not be discharged, except by complete payment and performance of the Fee Obligations.

(c) In the event any payment by Affiliate or any other person to Beneficiary is held to constitute a preference, fraudulent transfer or other voidable payment under any

bankruptcy, insolvency or similar law or, if, for any other reason, Beneficiary is required to refund such payment or pay the amount thereof to any other party, such payment by Affiliate or any other party to Beneficiary shall not constitute a release of Guarantor from any liability hereunder, and this Guaranty shall continue to be effective or shall be reinstated (notwithstanding any prior release, surrender or discharge by Beneficiary of this Guaranty or of Guarantor), as the case may be, with respect to, and to the extent this Guaranty covered any amounts so refunded or paid. this Guaranty shall apply to, any and all amounts so refunded by Beneficiary or paid by Beneficiary to another person (which amounts shall constitute part of the Fee Obligations), and any interest paid by Beneficiary and any attorneys' fees, costs and expenses paid or incurred by Beneficiary in connection with any such event. It is the intent of Guarantor and Beneficiary that the obligations and liabilities of Guarantor hereunder are absolute and unconditional under any and all circumstances and that until the Fee Obligations are fully and finally paid and performed, and until one hundred twenty (120) days have elapsed thereafter without the filing of a claim for refund or disgorgement, the obligations and liabilities of Guarantor hereunder shall not be discharged or released, in whole or in part, by any act or occurrence that might, but for the provisions of this Guaranty, be deemed a legal or equitable discharge or release of Guarantor.

(d) If acceleration of the time for payment of any amount payable by Affiliate under the Agreement is stayed or delayed by any law or tribunal, all such amounts shall nonetheless (to the extent same constitute Fee Obligations) be payable by Guarantor on demand by Beneficiary.

4. Term. This Guaranty is not limited to any period of time, but shall continue in full force and effect until the Fee Obligations have been fully performed, paid and discharged by Affiliate, or Guarantor, provided, however, except that notwithstanding any return

of this Guaranty to Guarantor, this Guaranty shall continue in effect (i) with respect to any of the Fee Obligations that survive the discharge of the Fee Obligations, (ii) with respect to all obligations and liabilities of Guarantor under Section 6, and (iii) as provided in Section 3(b). Notwithstanding any other provision of this Guaranty, the Guaranty may be terminated at any time in writing by Beneficiary.

5. Representations, Warranties and Covenants of Guarantor. Guarantor hereby represents, warrants and covenants that (a) Guarantor has a financial interest in Affiliate and will derive a material and substantial benefit, directly and indirectly, from the execution of the Agreement by Affiliate and the making of this Guaranty by Guarantor; (b) this Guaranty has been duly authorized pursuant to resolutions duly adopted by its Board of Directors, a true and correct copy of which is attached hereto as Exhibit A, and is binding upon and enforceable against Guarantor; (c) Guarantor is not, and the execution, delivery and performance by Guarantor of this Guaranty will not cause Guarantor to be, in violation of or in default with respect to any law or in default (or at risk of acceleration of indebtedness) under any document, indenture, agreement or restriction by which Guarantor is bound or affected; (d) Guarantor is duly organized and is validly existing and in good standing under the laws of Delaware and has full power and authority to enter into and perform this Guaranty; (e) except as set forth in the financial statements of Guarantor, there is no material litigation pending or, to the knowledge of Guarantor, threatened before or by any tribunal against or affecting either Guarantor; (f) all financial statements heretofore disclosed by Guarantor to Beneficiary fully and accurately present the financial condition of Guarantor as of its dates and the results of Guarantor's operations for the periods therein specified (furthermore, there has been no material adverse change in circumstances since the date such financials were submitted); (g) after giving effect to

this Guaranty. Guarantor is solvent, is not engaged or about to engage in business or a transaction for which the properties of Guarantor constitute an unreasonably small capital, and do not intend to incur or believe that they will incur debts that will be beyond its ability to pay as such debts mature; (h) Beneficiary has no duty at any time to investigate or inform Guarantor of the financial or business condition or affairs of Affiliate or any change therein, and Guarantor will keep fully apprised of Affiliate's financial and business condition; (i) Guarantor acknowledges and agrees that Guarantor may be required to pay and perform the Fee Obligations in full without assistance or support from Affiliate or any other person; and (j) Guarantor has read and fully understand the provisions contained in the Agreement. Guarantor's representations, warranties and covenants are a material inducement to Beneficiary to enter into the Agreement and shall survive the execution thereof and any bankruptcy, foreclosure, transfer of security or other event affecting Affiliate, Guarantor or any other party.

6. Attorney Fees and Translation Costs. In addition to the amounts guaranteed under this Guaranty, Guarantor agrees to pay actual reasonable attorney's fees and translation costs and all other reasonable costs and expenses incurred by the Beneficiary in any action or proceeding arising out of or relating to this Guaranty, including any action instituted to determine the respective rights and obligations of the parties hereunder and any action to enforce a judgment relating to this Guaranty (regardless of the venue of such action), whether or not suit is filed thereon, or whether in connection with bankruptcy, insolvency or appeal, provided, that and to the extent that the Beneficiary is the prevailing party in such action or proceeding.

7. Governing Law. This Guaranty is and shall be deemed to be a contract entered into in and pursuant to the laws of the State of Illinois and shall be governed and construed in accordance with the laws of Illinois without regard to its conflicts of laws rules for

all purposes, including, but not limited to, matters of construction, validity and performance. Guarantor hereby irrevocably submits generally and unconditionally for itself and in respect of its property to the jurisdiction of any state court, or any United States federal court, sitting in the County of Cook, State of Illinois, over any suit, action or proceeding arising out of or relating to this Guaranty or the Fee Obligations. The registered office of Guarantor in the State of Illinois shall be CT Corporation Services, 208 South LaSalle Street, Chicago, Illinois 60604 and the registered agent for service of process on Guarantor at the registered office shall be CT Corporation Services. Guarantor shall not change its registered agent for so long as this Guaranty is in effect unless such registered agent ceases to exist in which case the Guarantor will immediately notify the Beneficiary of a replacement agent to be located in Illinois. Guarantor hereby irrevocably waives, to the fullest extent permitted by law, any objection that Guarantor may now or hereafter have to the laying of venue in any such court and any claim that any such court is an inconvenient forum. Guarantor hereby agrees and consents that, in addition to any methods of service of process provided under applicable law, all service of process in any such suit, action or proceeding in any state court, or any United States federal court, sitting in the State of Illinois may be made by certified or registered mail, return receipt requested, directed, at Beneficiary's election, either (a) to Guarantor's registered agent at the address specified above or (b) to Guarantor at the address set forth in Section 12, or at a subsequent address in the continental United States of which Beneficiary received actual notice from Guarantor in accordance with Section 12, and service so made shall be complete five (5) days after the same shall have been so mailed, whether or not such service has been accepted or refused. Nothing herein shall affect the right of Beneficiary to serve process in any manner permitted by law or

limit the right of Beneficiary to bring proceedings against Guarantor in any other court or jurisdiction.

8. Severability. If any portion of this Guaranty is held to be invalid or unenforceable, such invalidity shall have no effect upon the remaining portions of this Guaranty, which shall be severable and continue in full force and effect to the maximum extent permitted by law or equity.

9. Binding on Successors. This Guaranty shall inure to the benefit of the Beneficiary and its successors and assigns. The Guarantor may not transfer, convey or assign this Guaranty, or any interest therein, without the prior written consent of the Beneficiary. The Guaranty shall be binding upon Guarantor and its successors and permitted assigns, including transferee(s) of substantially all of its assets and its shareholder(s) in the event of its dissolution or insolvency. Guarantor waives notice of any transfer or assignment of the Fee Obligations, or any part thereof, and Guarantor agrees that failure to give notice will not affect the liabilities of Guarantor hereunder.

10. Authority. Guarantor represents and warrants that it has the power and authority to give this Guaranty, that its execution of this Guaranty has been authorized by all necessary action under its organizational documents and applicable law, and that the person or persons signing this Guaranty on its behalf have the authority to do so.

11. Subordination. Any claims Guarantor may have against Affiliate are hereby subordinated to any and all claims of the Beneficiary against Affiliate until such time as the obligations of Affiliate to the Beneficiary are fully satisfied and discharged.

12. Notices. Notice shall be given in writing, deposited in the U.S. mail, registered or certified, first class postage prepaid, addressed as follows:

To the Guarantor: JCDecaux North America, Inc.
3 Park Avenue, 33rd Floor
New York, New York 10016
Attention: Bernard Parisot

with a copy to: Greenberg Traurig
200 Park Avenue, 15th Floor
New York, New York 10166
Attention: Edward C. Wallace, Esq.

To Beneficiary : City of Chicago
Office of the Mayor
City Hall, Room 406
121 North LaSalle Street
Chicago, IL 60602

with a copy to: City of Chicago
Corporation Counsel
City Hall, Room 600
121 North LaSalle Street
Chicago, IL 60611-1575

Nothing in this Guaranty shall preclude or waive any notices to Affiliate for breach or default and opportunity to cure any breach or default which are required to be given pursuant to the Agreement, and copies of any such notices given to Affiliate for breach or default shall be copied to Guarantor at the address provided above, provided, however, this section shall not be construed in any way to affect or impair any waiver of notice or demand provided in this Guaranty or in the Agreement or to require giving of notice or demand to or upon any person in any situation or for any reason.

13. Cumulative Rights. The exercise by Beneficiary of any right or remedy hereunder or under the Agreement, or at law or in equity, shall not preclude the concurrent or subsequent exercise of any other right or remedy. Beneficiary shall have all rights, remedies

and recourses afforded to Beneficiary by reason of this Guaranty or the Agreement or by law or equity or otherwise, and the same (a) shall be cumulative and concurrent, (b) may be pursued separately, successively or concurrently against Guarantor, or others obligated for the Fee Obligations or any part thereof, or any of Affiliate's obligations under the Agreement, or against any one or more of them, or against any security or otherwise, at the sole discretion of Beneficiary, (c) may be exercised as often as occasion therefor shall arise, it being agreed by Guarantor that the exercise of, discontinuance of the exercise of or failure to exercise any of such rights, remedies, or recourses shall in no event be construed as a waiver or release thereof or of any other right, remedy, or recourse, and (d) are intended to be, and shall be, nonexclusive. No waiver of any default on the part of Guarantor or of any breach of any of the provisions of this Guaranty shall be considered a waiver of any other or subsequent default or breach, and no delay or omission in exercising or enforcing the rights and powers granted herein or in any other document shall be construed as a waiver of such rights and powers, and no exercise or enforcement of any rights or powers hereunder or under any other document shall be held to exhaust such rights and powers, and every such right and power may be exercised from time to time. The granting of any consent, approval or waiver by Beneficiary shall be limited to the specific instance and purpose therefor and shall not constitute consent or approval in any other instance or for any other purpose. No notice to or demand on Guarantor in any case shall in and of itself entitle Guarantor to any other or further notice or demand in similar or other circumstances. No provision of this Guaranty or any right, remedy or recourse of Beneficiary with respect hereto, or any default or breach, can be waived, nor can this Guaranty or Guarantor be released or discharged in any way or to any extent, except specifically in each case by a

writing intended for that purpose (and which refers specifically to this Guaranty) executed, and delivered to Guarantor, by Beneficiary.

14. Entire Agreement. This Guaranty embodies the entire agreement between Beneficiary and Guarantor with respect to the guaranty by Guarantor of the Fee Obligations. This Guaranty supersedes all prior agreements and understandings, if any, with respect to guaranty by Guarantor of the Fee Obligations. No condition or conditions precedent to the effectiveness of this Guaranty exist. This Guaranty shall be effective upon execution by Guarantor and delivery to Beneficiary. This Guaranty may not be modified, amended or superseded except in a writing signed by Beneficiary and Guarantor referencing this Guaranty by its date and specifically identifying the portions hereof that are to be modified, amended or superseded.

15. WAIVER OF JURY TRIAL. GUARANTOR HEREBY WAIVES TRIAL BY JURY IN ANY ACTION OR PROCEEDING TO WHICH GUARANTOR OR BENEFICIARY MAY BE PARTIES ARISING OUT OF, IN CONNECTION WITH, OR IN ANY WAY PERTAINING TO, THIS GUARANTY OR THE AGREEMENT. IT IS AGREED AND UNDERSTOOD THAT THIS WAIVER CONSTITUTES A WAIVER OF TRIAL BY JURY OF ALL CLAIMS AGAINST ALL PARTIES TO SUCH ACTIONS OR PROCEEDINGS, INCLUDING CLAIMS AGAINST PARTIES WHO ARE NOT PARTIES TO THIS GUARANTY. THIS WAIVER IS KNOWINGLY, WILLINGLY AND VOLUNTARILY MADE BY GUARANTOR, AND GUARANTOR HEREBY REPRESENTS THAT NO REPRESENTATIONS OF FACT OR OPINION HAVE BEEN MADE BY ANY INDIVIDUAL TO INDUCE THIS WAIVER OF TRIAL BY JURY OR TO IN ANY WAY MODIFY OR NULLIFY ITS EFFECT. GUARANTOR FURTHER REPRESENTS AND WARRANTS

THAT IT HAS BEEN REPRESENTED IN THE SIGNING OF THIS GUARANTY AND IN THE MAKING OF THIS WAIVER BY INDEPENDENT LEGAL COUNSEL, AND THAT IT HAVE HAD THE OPPORTUNITY TO DISCUSS THIS WAIVER WITH COUNSEL.

16. Consent to Jurisdiction. Guarantor irrevocably submits generally and unconditionally for itself and in respect of its property to the nonexclusive jurisdiction of the courts specified in Section 7 hereof. Final, non-appealable judgment in any suit, action or proceeding brought in any such court shall be conclusive and binding upon Guarantor and may be enforced in any court within or outside the United States of America, in which Guarantor is subject to jurisdiction, by a suit upon such judgment provided that service of process is effected upon Guarantor as permitted herein or by applicable law. Guarantor hereby releases, to the extent permitted by applicable law, all errors and all rights of exemption, appeal, stay of execution, inquisition, and other rights to which the Guarantor may otherwise be entitled under the laws of the United States of America or any state, possession or territory of the United States of America, now in force or which may hereinafter be enacted. The authority and power to appear for and enter judgment against the Guarantor shall not be exhausted by one or more exercises thereof or by any imperfect exercise thereof and shall not be extinguished by any judgment entered pursuant thereto. Such authority may be exercised on one or more occasions or from time to time in the same or different jurisdiction as often as Beneficiary shall deem necessary and desirable, for all of which this Guaranty shall be sufficient warrant.

IN WITNESS WHEREOF, Guarantor has executed this Guaranty as of the day and year first above written.

JCDECAUX NORTH AMERICA, INC.
a Delaware corporation

By: _____
Name: Bernard Parisot
Title: Co-CEO

|

GUARANTY

THIS GUARANTY (the "Guaranty") is given as of the ___ day of June, 2002 by JCDecaux S.A., a French Société Anonyme ("Guarantor"), to the City of Chicago, a municipal corporation (hereinafter "Beneficiary").

RECITALS:

WHEREAS, JCDecaux Chicago LLC, an Illinois limited liability company ("Affiliate"), is a wholly-owned subsidiary of JCDecaux North America Inc., and JCDecaux North America Inc. is a wholly-owned subsidiary of Guarantor;

WHEREAS, Affiliate and Beneficiary have entered into a Coordinated Street Furniture Program Agreement (the "Agreement"), dated as of June ___, 2002; and

WHEREAS, it is in the best interest of the Guarantor to execute this Guaranty and Guarantor will derive substantial benefits from the Agreement, and Guarantor has agreed to provide this Guaranty to induce Beneficiary to enter into the Agreement.

NOW, THEREFORE, in consideration of the foregoing, and for other good and valuable consideration, the receipt and adequacy of which are hereby acknowledged, and as a material inducement to Beneficiary to enter into the Agreement, Guarantor agrees as follows:

1. Guaranty of Payment and Performance. Guarantor hereby irrevocably and unconditionally guarantees to Beneficiary the complete and timely payment to Beneficiary of Contractor Fees and all other financial obligations such as payment of liquidated damages, if applicable, as described in the Agreement which Affiliate is required to pay pursuant to the

Agreement (the "Fee Obligations"). In the event that Affiliate fails to pay its Fee Obligations, Guarantor will promptly and fully make payments to satisfy the Fee Obligations in the place of Affiliate. Except as set forth above, nothing contained herein shall be construed as obligating Guarantor to pay or perform any obligations of Affiliate other than the Fee Obligations.

2. Guarantor's Fee Obligations Are Absolute.

(a) This Guaranty is an absolute, irrevocable and unconditional guaranty of payment and performance and is not a guaranty of collection. Guarantor shall be liable for the payment of the Fee Obligations, as set forth in this Guaranty, as a primary obligor. This Guaranty shall be effective as a waiver of, and Guarantor hereby expressly waives, any and all rights to which Guarantor may otherwise have been entitled under any suretyship laws in effect from time to time; including any right or privilege, whether existing under statute, at law or in equity, to require Beneficiary to take prior recourse or proceedings against any collateral, security or person whatsoever.

(b) Guarantor hereby agrees that in the event of (i) an event of default by Affiliate under the Agreement; (ii) the dissolution or insolvency of Guarantor; or (iii) the institution of any proceeding by or against Guarantor in bankruptcy or for a reorganization or an arrangement with creditors, or for the appointment of a receiver, trustee or custodian for any of them or for any of its properties; provided if such proceeding is instituted against Guarantor, then such proceeding shall not cause the Fee Obligations to be immediately due and payable if such proceeding is dismissed within one hundred twenty (120) days of filing; if not dismissed within one hundred and twenty (120) days of filing then the Fee Obligations, for purposes of this Guaranty, shall be deemed immediately due and payable at the election of Beneficiary under its

rights in the Agreement, and Guarantor shall, on demand and without presentment, protest, notice of protest, further notice of nonpayment or of dishonor or of default or nonperformance, or notice of acceleration or of intent to, or any other notice whatsoever, without any notice having been given to Guarantor previous to such demand of the acceptance by Beneficiary of this Guaranty, and without any notice having been given to Guarantor previous to such demand of the creating or incurring of such indebtedness or of such obligation to perform, all such notices being hereby waived by Guarantor, pay the Fee Obligations to Beneficiary, and it shall not be necessary for Beneficiary, in order to enforce such payment or performance by Guarantor, first to institute suit or pursue or exhaust any rights or remedies against Affiliate or any other guarantor of the Fee Obligations for payment, or to institute suit or pursue or exhaust any rights or remedies against Affiliate, and any other Guarantor or surety of the Fee Obligations, or to enforce any rights against any security that shall ever have been given to secure the Fee Obligations, or to join Affiliate, or any other Guarantor or surety for the payment of the Fee Obligations or any part thereof in any action to enforce this Guaranty, or to resort to any other means of obtaining payment of the Fee Obligations.

(c) Suit may be brought or demand may be made against the Guarantor, and any other obligor under any other guaranty covering all or any part of the Fee Obligations without impairing the rights of Beneficiary against Guarantor, or any other Guarantor or surety.

3. Waivers.

(a) Except to the extent the Fee Obligations have been satisfied, Guarantor hereby agrees that neither Beneficiary's rights or remedies nor Guarantor's obligations under the terms of this Guaranty shall be released, diminished, impaired, reduced or affected by any one or

more of the following events, actions, facts, or circumstances, and the liability of Guarantor under this Guaranty shall be absolute and unconditional irrespective of:

(i) any claim or defense that this Guaranty was made without consideration or is not supported by adequate consideration;

(ii) the taking or accepting of any other security or guaranty for, or right of recourse with respect to, any or all of the Fee Obligations;

(iii) the availability to Guarantor of any exemption or defense under applicable law;

(iv) any release, surrender, abandonment, exchange, alteration, sale or other disposition, subordination, deterioration, waste, failure to protect or preserve, impairment, or loss of, or any failure to create or perfect any lien or security interest with respect to, or any other dealings with, any collateral or security at any time existing or purported, believed or expected to exist in connection with any or all of the Fee Obligations, including any impairment of Guarantor's recourse against any person or collateral;

(v) whether express or by operation of law, any partial release of the liability of Guarantor hereunder, or if one or more other guaranties are now or hereafter obtained by Beneficiary from any other guarantor covering all or any part of the Fee Obligations, any complete or partial release of any other guarantor under any such other guaranty, or any complete or partial release of or settlement with Affiliate;

(vi) the insolvency, bankruptcy, dissolution, liquidation, termination, receivership, reorganization, merger, consolidation, change of form, structure or ownership, sale

of all assets, or lack of corporate, partnership or other power of Affiliate or any other guarantor or surety at any time liable for the payment or performance of any or all of the Fee Obligations:

(vii) either with or without notice to or consent of Guarantor: any renewal, extension, modification or rearrangement of the terms of any or all of the Fee Obligations and/or the Agreement, or any waiver, termination, or release of, or consent to departure from, the Agreement or any other guaranty of any or all of the Fee Obligations, or any adjustment, indulgence, forbearance, or compromise that may be granted from time to time by Beneficiary to Affiliate, Guarantor, and/or any other guarantor or surety liable for all or any portion of the Fee Obligations;

(viii) any neglect, lack of diligence, delay, omission, forbearance, failure, or refusal of Beneficiary to take or prosecute (or in taking or prosecuting) any action for the collection or enforcement of any of the Fee Obligations, or to take or prosecute any action upon any security therefor, or to exercise (or in exercising) any other right or power with respect to any security therefor, or to take or prosecute (or in taking or prosecuting) any action in connection with the Agreement, or any failure to sell or otherwise dispose of in a commercially reasonable manner any collateral securing any or all of the Fee Obligations;

(ix) any failure of Beneficiary to notify Guarantor of any creation, renewal, extension, rearrangement, modification, supplement, subordination, or assignment of the Fee Obligations or any part thereof, or of the Agreement, or of any release of or change in any security, or of any other action taken or refrained from being taken by Beneficiary against Affiliate or any other guarantor, or any security or other recourse, or of any new agreement between Beneficiary and Affiliate or between Beneficiary and any other guarantor, it being

understood that, except with respect to the requirements for the service of process required to commence a lawsuit against Guarantor, Beneficiary shall not be required to give Guarantor any notice of any kind under any circumstances with respect to or in connection with the Fee Obligations, any and all rights to notice Guarantor may have otherwise had being hereby waived by Guarantor, and the Guarantor shall be responsible for obtaining for itself information regarding Affiliate, including, but not limited to, any changes in the business or financial condition of Affiliate, and Guarantor acknowledges and agrees that Beneficiary shall have no duty to notify Guarantor of any information which Beneficiary may have concerning Affiliate;

(x) if any requirement for any reason that Beneficiary is required to refund any payment by Affiliate to any other party liable for the payment or performance of any or all of the Fee Obligations or pay the amount thereof to someone else;

(xi) the existence of any claim, counterclaim, set-off, recoupment, reduction or defense based upon any claim or other right that Guarantor may at any time have against Affiliate, Beneficiary, or any other person, whether or not arising in connection with this Guaranty or the Agreement;

(xii) the unenforceability of all or any part of the Fee Obligations against Affiliate, whether because the Fee Obligations exceed the amount permitted by law or violate any usury law, or because the act of creating the Fee Obligations, or any part thereof, is ultra vires, or because the officers or persons creating same acted in excess of its authority, or because of a lack of validity or enforceability of or defect or deficiency in the Agreement or because Affiliate has any valid defense, claim or offset with respect thereto, or because Affiliate's obligation ceases to exist by operation of law, or because of any other reason or circumstance, it

being agreed that Guarantor shall remain liable hereon regardless of whether Affiliate, or any other person be found not liable on the Fee Obligations, or any part thereof, for any reason (and regardless of any joinder of Affiliate or any other party in any action to obtain payment or performance of any or all of the Fee Obligations); or

(xiii) any order, ruling or plan of reorganization emanating from proceedings under Title 11 of the United States Code with respect to Affiliate, or any other person, including any extension, reduction, composition, or other alteration of the Fee Obligations, whether or not consented to Beneficiary.

(b) Guarantor hereby waives (i) notice of acceptance of this Guaranty; (ii) notice of any advances made by Beneficiary in connection with the Agreement; (iii) notice of any waiver, amendment, modification, postponement, release, renewal, extension, accrual or termination of any of the Fee Obligations or the Agreement; (iv) notice of the reliance of Beneficiary upon this Guaranty; (v) notice of the occurrence, existence or continuance of any event of default, or failure of payment or performance under this Agreement; (vi) demand for payment, diligence, presentment, filing of claims with a court in the event of receivership or bankruptcy of the Affiliate, protest or notice with respect to the Fee Obligations, and all demands whatsoever; and (vii) any other notice, demand, protest or formality which would otherwise be legally required to charge Guarantor with liability hereunder; and Guarantor covenants and agrees that this Guaranty will not be discharged, except by complete payment and performance of the Fee Obligations.

(c) In the event any payment by Affiliate or any other person to Beneficiary is held to constitute a preference, fraudulent transfer or other voidable payment under any

bankruptcy, insolvency or similar law or, if, for any other reason, Beneficiary is required to refund such payment or pay the amount thereof to any other party, such payment by Affiliate or any other party to Beneficiary shall not constitute a release of Guarantor from any liability hereunder, and this Guaranty shall continue to be effective or shall be reinstated (notwithstanding any prior release, surrender or discharge by Beneficiary of this Guaranty or of Guarantor), as the case may be, with respect to, and to the extent this Guaranty covered any amounts so refunded or paid, this Guaranty shall apply to, any and all amounts so refunded by Beneficiary or paid by Beneficiary to another person (which amounts shall constitute part of the Fee Obligations), and any interest paid by Beneficiary and any attorneys' fees, costs and expenses paid or incurred by Beneficiary in connection with any such event. It is the intent of Guarantor and Beneficiary that the obligations and liabilities of Guarantor hereunder are absolute and unconditional under any and all circumstances and that until the Fee Obligations are fully and finally paid and performed, and until one hundred twenty (120) days have elapsed thereafter without the filing of a claim for refund or disgorgement, the obligations and liabilities of Guarantor hereunder shall not be discharged or released, in whole or in part, by any act or occurrence that might, but for the provisions of this Guaranty, be deemed a legal or equitable discharge or release of Guarantor.

(d) If acceleration of the time for payment of any amount payable by Affiliate under the Agreement is stayed or delayed by any law or tribunal, all such amounts shall nonetheless (to the extent same constitute Fee Obligations) be payable by Guarantor on demand by Beneficiary.

4. Term. This Guaranty is not limited to any period of time, but shall continue in full force and effect until the Fee Obligations have been fully performed, paid and discharged by Affiliate, or Guarantor, provided, however, except that notwithstanding any return

of this Guaranty to Guarantor, this Guaranty shall continue in effect (i) with respect to any of the Fee Obligations that survive the discharge of the Fee Obligations, (ii) with respect to all obligations and liabilities of Guarantor under Section 6, and (iii) as provided in Section 3(b). Notwithstanding any other provision of this Guaranty, the Guaranty may be terminated at any time in writing by Beneficiary.

5. Representations, Warranties and Covenants of Guarantor. Guarantor hereby represents, warrants and covenants that (a) Guarantor has a financial interest in Affiliate and will derive a material and substantial benefit, directly and indirectly, from the execution of the Agreement by Affiliate and the making of this Guaranty by Guarantor; (b) this Guaranty has been duly authorized pursuant to resolutions duly adopted by its Board of Directors, a true and correct copy of which is attached hereto as Exhibit A, and is binding upon and enforceable against Guarantor; (c) Guarantor is not, and the execution, delivery and performance by Guarantor of this Guaranty will not cause Guarantor to be, in violation of or in default with respect to any law or in default (or at risk of acceleration of indebtedness) under any document, indenture, agreement or restriction by which Guarantor is bound or affected; (d) Guarantor is duly organized and is validly existing and in good standing under the laws of Delaware and has full power and authority to enter into and perform this Guaranty; (e) except as set forth in the financial statements of Guarantor, there is no material litigation pending or, to the knowledge of Guarantor, threatened before or by any tribunal against or affecting either Guarantor; (f) all financial statements heretofore disclosed by Guarantor to Beneficiary fully and accurately present the financial condition of Guarantor as of its dates and the results of Guarantor's operations for the periods therein specified (furthermore, there has been no material adverse change in circumstances since the date such financials were submitted); (g) after giving effect to

this Guaranty, Guarantor is solvent, is not engaged or about to engage in business or a transaction for which the properties of Guarantor constitute an unreasonably small capital, and do not intend to incur or believe that they will incur debts that will be beyond its ability to pay as such debts mature; (h) Beneficiary has no duty at any time to investigate or inform Guarantor of the financial or business condition or affairs of Affiliate or any change therein, and Guarantor will keep fully apprised of Affiliate's financial and business condition; (i) Guarantor acknowledges and agrees that Guarantor may be required to pay and perform the Fee Obligations in full without assistance or support from Affiliate or any other person; and (j) Guarantor has read and fully understand the provisions contained in the Agreement. Guarantor's representations, warranties and covenants are a material inducement to Beneficiary to enter into the Agreement and shall survive the execution thereof and any bankruptcy, foreclosure, transfer of security or other event affecting Affiliate, Guarantor or any other party.

6. Attorney Fees and Translation Costs. In addition to the amounts guaranteed under this Guaranty, Guarantor agrees to pay actual reasonable attorney's fees and translation costs and all other reasonable costs and expenses incurred by the Beneficiary in any action or proceeding arising out of or relating to this Guaranty, including any action instituted to determine the respective rights and obligations of the parties hereunder and any action to enforce a judgment relating to this Guaranty (regardless of the venue of such action), whether or not suit is filed thereon, or whether in connection with bankruptcy, insolvency or appeal, provided, that and to the extent that the Beneficiary is the prevailing party in such action or proceeding.

7. Governing Law. This Guaranty is and shall be deemed to be a contract entered into in and pursuant to the laws of the State of Illinois and shall be governed and construed in accordance with the laws of Illinois without regard to its conflicts of laws rules for

all purposes, including, but not limited to, matters of construction, validity and performance. Guarantor hereby irrevocably submits generally and unconditionally for itself and in respect of its property to the jurisdiction of any state court, or any United States federal court, sitting in the County of Cook, State of Illinois, over any suit, action or proceeding arising out of or relating to this Guaranty or the Fee Obligations. The registered office of Guarantor in the State of Illinois shall be CT Corporation Services, 208 South LaSalle Street, Chicago, Illinois 60604 and the registered agent for service of process on Guarantor at the registered office shall be CT Corporation Services. Guarantor shall not change its registered agent for so long as this Guaranty is in effect unless such registered agent ceases to exist in which case the Guarantor will immediately notify the Beneficiary of a replacement agent to be located in Illinois. Guarantor hereby irrevocably waives, to the fullest extent permitted by law, any objection that Guarantor may now or hereafter have to the laying of venue in any such court and any claim that any such court is an inconvenient forum. Guarantor hereby agrees and consents that, in addition to any methods of service of process provided under applicable law, all service of process in any such suit, action or proceeding in any state court, or any United States federal court, sitting in the State of Illinois may be made by certified or registered mail, return receipt requested, directed, at Beneficiary's election, either (a) to Guarantor's registered agent at the address specified above or (b) to Guarantor at the address set forth in Section 12, or at a subsequent address in the continental United States of which Beneficiary received actual notice from Guarantor in accordance with Section 12, and service so made shall be complete five (5) days after the same shall have been so mailed, whether or not such service has been accepted or refused. Nothing herein shall affect the right of Beneficiary to serve process in any manner permitted by law or

limit the right of Beneficiary to bring proceedings against Guarantor in any other court or jurisdiction.

8. Severability. If any portion of this Guaranty is held to be invalid or unenforceable, such invalidity shall have no effect upon the remaining portions of this Guaranty, which shall be severable and continue in full force and effect to the maximum extent permitted by law or equity.

9. Binding on Successors. This Guaranty shall inure to the benefit of the Beneficiary and its successors and assigns. The Guarantor may not transfer, convey or assign this Guaranty, or any interest therein, without the prior written consent of the Beneficiary. The Guaranty shall be binding upon Guarantor and its successors and permitted assigns, including transferee(s) of substantially all of its assets and its shareholder(s) in the event of its dissolution or insolvency. Guarantor waives notice of any transfer or assignment of the Fee Obligations, or any part thereof, and Guarantor agrees that failure to give notice will not affect the liabilities of Guarantor hereunder.

10. Authority. Guarantor represents and warrants that it has the power and authority to give this Guaranty, that its execution of this Guaranty has been authorized by all necessary action under its organizational documents and applicable law, and that the person or persons signing this Guaranty on its behalf have the authority to do so.

11. Subordination. Any claims Guarantor may have against Affiliate are hereby subordinated to any and all claims of the Beneficiary against Affiliate until such time as the obligations of Affiliate to the Beneficiary are fully satisfied and discharged.

12. Notices. Notice shall be given in writing, deposited in the U.S. mail, registered or certified, first class postage prepaid, addressed as follows:

To the Guarantor: JCDecaux North America, Inc.
3 Park Avenue, 33rd Floor
New York, New York 10016
Attention: Bernard Parisot

with a copy to: Greenberg Traurig
200 Park Avenue, 15th Floor
New York, New York 10166
Attention: Edward C. Wallace, Esq.

To Beneficiary : City of Chicago
Office of the Mayor
City Hall, Room 406
121 North La Salle Street
Chicago, IL 60602

with a copy to: City of Chicago
Corporation Counsel
City Hall, Room 600
121 North LaSalle Street
Chicago, IL 60611-1575

Nothing in this Guaranty shall preclude or waive any notices to Affiliate for breach or default and opportunity to cure any breach or default which are required to be given pursuant to the Agreement, and copies of any such notices given to Affiliate for breach or default shall be copied to Guarantor at the address provided above, provided, however, this section shall not be construed in any way to affect or impair any waiver of notice or demand provided in this Guaranty or in the Agreement or to require giving of notice or demand to or upon any person in any situation or for any reason.

13. Cumulative Rights. The exercise by Beneficiary of any right or remedy hereunder or under the Agreement, or at law or in equity, shall not preclude the concurrent or subsequent exercise of any other right or remedy. Beneficiary shall have all rights, remedies

and recourses afforded to Beneficiary by reason of this Guaranty or the Agreement or by law or equity or otherwise, and the same (a) shall be cumulative and concurrent, (b) may be pursued separately, successively or concurrently against Guarantor, or others obligated for the Fee Obligations or any part thereof, or any of Affiliate's obligations under the Agreement, or against any one or more of them, or against any security or otherwise, at the sole discretion of Beneficiary. (c) may be exercised as often as occasion therefor shall arise, it being agreed by Guarantor that the exercise of, discontinuance of the exercise of or failure to exercise any of such rights, remedies, or recourses shall in no event be construed as a waiver or release thereof or of any other right, remedy, or recourse, and (d) are intended to be, and shall be, nonexclusive. No waiver of any default on the part of Guarantor or of any breach of any of the provisions of this Guaranty shall be considered a waiver of any other or subsequent default or breach, and no delay or omission in exercising or enforcing the rights and powers granted herein or in any other document shall be construed as a waiver of such rights and powers, and no exercise or enforcement of any rights or powers hereunder or under any other document shall be held to exhaust such rights and powers, and every such right and power may be exercised from time to time. The granting of any consent, approval or waiver by Beneficiary shall be limited to the specific instance and purpose therefor and shall not constitute consent or approval in any other instance or for any other purpose. No notice to or demand on Guarantor in any case shall in and of itself entitle Guarantor to any other or further notice or demand in similar or other circumstances. No provision of this Guaranty or any right, remedy or recourse of Beneficiary with respect hereto, or any default or breach, can be waived, nor can this Guaranty or Guarantor be released or discharged in any way or to any extent, except specifically in each case by a

writing intended for that purpose (and which refers specifically to this Guaranty) executed, and delivered to Guarantor, by Beneficiary.

14. Entire Agreement. This Guaranty embodies the entire agreement between Beneficiary and Guarantor with respect to the guaranty by Guarantor of the Fee Obligations. This Guaranty supersedes all prior agreements and understandings, if any, with respect to guaranty by Guarantor of the Fee Obligations. No condition or conditions precedent to the effectiveness of this Guaranty exist. This Guaranty shall be effective upon execution by Guarantor and delivery to Beneficiary. This Guaranty may not be modified, amended or superseded except in a writing signed by Beneficiary and Guarantor referencing this Guaranty by its date and specifically identifying the portions hereof that are to be modified, amended or superseded.

15. WAIVER OF JURY TRIAL. GUARANTOR HEREBY WAIVES TRIAL BY JURY IN ANY ACTION OR PROCEEDING TO WHICH GUARANTOR OR BENEFICIARY MAY BE PARTIES ARISING OUT OF, IN CONNECTION WITH, OR IN ANY WAY PERTAINING TO, THIS GUARANTY OR THE AGREEMENT. IT IS AGREED AND UNDERSTOOD THAT THIS WAIVER CONSTITUTES A WAIVER OF TRIAL BY JURY OF ALL CLAIMS AGAINST ALL PARTIES TO SUCH ACTIONS OR PROCEEDINGS, INCLUDING CLAIMS AGAINST PARTIES WHO ARE NOT PARTIES TO THIS GUARANTY. THIS WAIVER IS KNOWINGLY, WILLINGLY AND VOLUNTARILY MADE BY GUARANTOR, AND GUARANTOR HEREBY REPRESENTS THAT NO REPRESENTATIONS OF FACT OR OPINION HAVE BEEN MADE BY ANY INDIVIDUAL TO INDUCE THIS WAIVER OF TRIAL BY JURY OR TO IN ANY WAY MODIFY OR NULLIFY ITS EFFECT. GUARANTOR FURTHER REPRESENTS AND WARRANTS

THAT IT HAS BEEN REPRESENTED IN THE SIGNING OF THIS GUARANTY AND IN THE MAKING OF THIS WAIVER BY INDEPENDENT LEGAL COUNSEL, AND THAT IT HAVE HAD THE OPPORTUNITY TO DISCUSS THIS WAIVER WITH COUNSEL.

16. Consent to Jurisdiction. Guarantor irrevocably submits generally and unconditionally for itself and in respect of its property to the nonexclusive jurisdiction of the courts specified in Section 7 hereof. Final, non-appealable judgment in any suit, action or proceeding brought in any such court shall be conclusive and binding upon Guarantor and may be enforced in any court within or outside the United States of America, in which Guarantor is subject to jurisdiction, by a suit upon such judgment provided that service of process is effected upon Guarantor as permitted herein or by applicable law. Guarantor hereby releases, to the extent permitted by applicable law, all errors and all rights of exemption, appeal, stay of execution, inquisition, and other rights to which the Guarantor may otherwise be entitled under the laws of France, the United States of America or any state, possession or territory of the United States of America or France, now in force or which may hereinafter be enacted. The authority and power to appear for and enter judgment against the Guarantor shall not be exhausted by one or more exercises thereof or by any imperfect exercise thereof and shall not be extinguished by any judgment entered pursuant thereto. Such authority may be exercised on one or more occasions or from time to time in the same or different jurisdiction as often as Beneficiary shall deem necessary and desirable, for all of which this Guaranty shall be sufficient warrant.

The Guarantor hereby waives the benefit of the privilege of jurisdiction provided by Article 15 of the Civil Code of France.

IN WITNESS WHEREOF, Guarantor has executed this Guaranty as of the day
and year first above written.

JCDECAUX S.A.,
a French Société Anonyme

By: _____
Name: Jean-Francois Decaux
Title: CEO

EXHIBIT 13
Map of CBD-A

Boundaries:

— CBD - A

6/28/2002

